

Job Name: 26-1077 - Westside Markets of Greensboro Village  
 Job Location: Gallatin, TN  
 Contractor: Cleary Construction, Inc.

Plant: 100  
 3/27/2026 4:34:14 PM

Tech: J. Horsley - F  
 PC: C. Goff



**Structure ID: A8**

**P2 MH060RSVF**

**MH RISER Custom Ht F/G**

P4) 30" x 36" - CASTING HEIGHT - 6.50"	0 lb
P3) 60" - MH FLAT TOP w/30"x36" Hole F/F - 8"	2008 lb
P2) 60" - MH RISER Custom Ht F/G - 19"	1941 lb
P1) 60" - MH BASE Custom Ht T/n - 70"	8660 lb
1) 60" - STORM INVERT CHANNEL - 1/4 HEIGHT	1700 lb
2) 60" - Conseal CS-102 1.00"	0 lb
2) Hole - 38	0 lb
1) Hole - 20	0 lb
3) Hole - 6	0 lb
6) MH Step ML-10-TDS-NCR - 10"	0 lb
<b>Structure Total:</b>	<b>14309 lb</b>

**Structure Notes:**  
 1. PER ASTM C478 SPECIFICATIONS.  
 2. CONCRETE = 4,000 PSI AT 28 DAYS.  
 3. CASTING SUPPLIED BY OTHERS (JBS 2064 F/G/H - SINGLE CURB INLET).  
  
 REINFORCING PER ASTM A615 (GRADE 60).  
 - TOP SLAB (As .62) #5 BARS AT 6" C.C.E.W..  
 - RISER/WALLS (As .18)  
 - FLOOR (As .37) #5 BARS AT 10" C.C.E.W.

Rim: 501.6' Rim to Invert: 8.47' Slack: 0.69' Sump: 2.55' Step Position: 276.5°

Position	Elev	Angle	Ext. (cw)	Pipe	Pipe OD	Connector	Hole	Horz Size	Up ( )	Offset
Invert 1										
Invert 2										
Invert 3										
Invert 4	499.5'	0°	0"	4" HDPE (perf pipe)	4.8"	Hole 6	6"	6.01"	3.875"	0"
Invert 5	499.5'	90°	56.5"	4" HDPE (perf pipe)	4.8"	Hole 6	6"	6.01"	3.875"	0"
Invert 6	499.5'	180°	113.125"	4" HDPE (perf pipe)	4.8"	Hole 6	6"	6.01"	3.875"	0"
Invert 7										
Invert 8										

**RIGHT-SIDE UP VIEW (int. dimensions)**

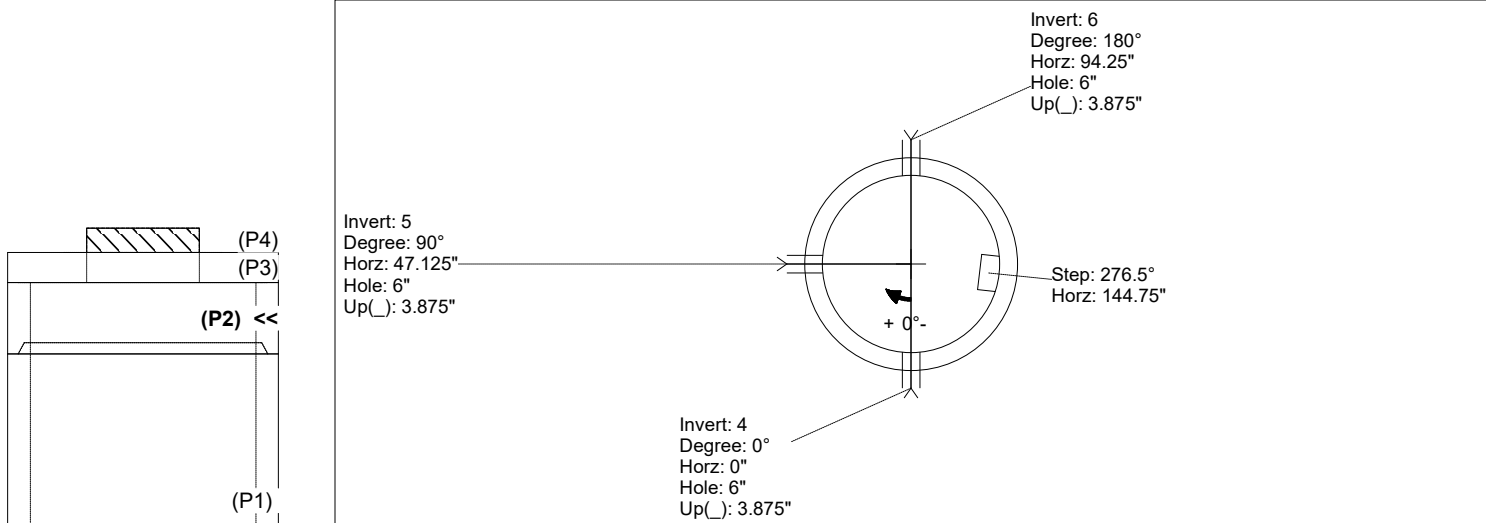

**INSIDE WALL DIMENSIONS**

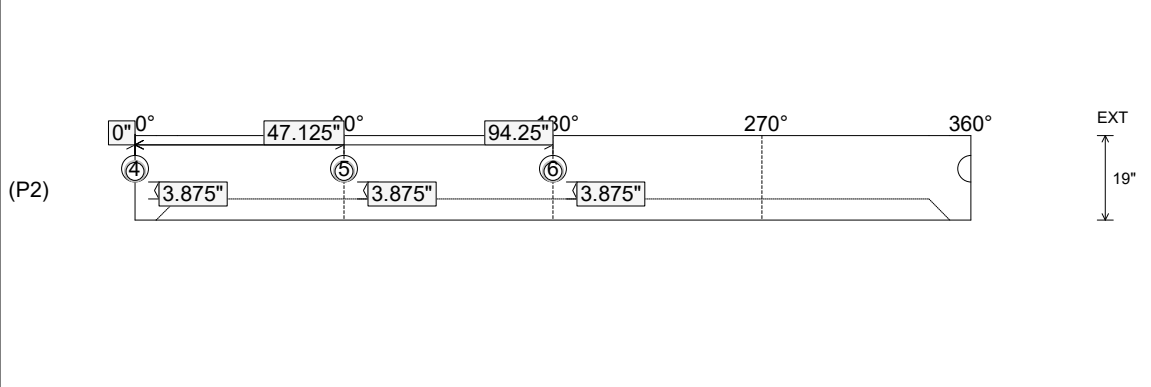

Coating (Int): Coating (Ext):	Seam Up: Flat Seam Dn: Groove	Wall Thickness: 6" Floor Height: 0"	Height (Int): 19" Height (Ext): 19"	Weight (Net): 1941 lb Volume (Net): 0.5cu.yd
----------------------------------	----------------------------------	--	--	---