

Job Name: 26-1077 - Westside Markets of Greensboro Village  
 Job Location: Gallatin, TN  
 Contractor: Cleary Construction, Inc.

Plant: 100  
 3/27/2026 4:33:35 PM

Tech: J. Horsley - F  
 PC: C. Goff



**Structure ID: A6**

**P1 MH060BAVF**

**MH BASE Custom Ht T/n**

- P4) 30" x 36" - CASTING HEIGHT - 6.50"
- P3) 60" - MH FLAT TOP w/30"x36" Hole F/G - 13"
- P2) 60" - MH RISER T/G - 48"
- P1) 60" - MH BASE Custom Ht T/n - 45"
- 1) 60" - STORM INVERT CHANNEL - 1/4 HEIGHT
- 2) 60" - Conseal CS-102 1.00"
- 2) Hole - 38
- 3) Hole - 6
- 8) MH Step ML-10-TDS-NCR - 10"

0 lb  
 2834 lb  
 4968 lb  
 6211 lb  
 1700 lb  
 0 lb  
 0 lb  
 0 lb  
 0 lb  
 0 lb  
 Structure Total: 15714 lb

**Structure Notes:**  
 1. PER ASTM C478 SPECIFICATIONS.  
 2. CONCRETE = 4,000 PSI AT 28 DAYS.  
 3. CASTING SUPPLIED BY OTHERS (JBS 2064 F/G/H - SINGLE CURB INLET).  
  
 REINFORCING PER ASTM A615 (GRADE 60).  
 - TOP SLAB (As .62) #5 BARS AT 6" C.C.E.W..  
 - RISER/WALLS (As .18)  
 - FLOOR (As .37) #5 BARS AT 10" C.C.E.W.

Rim: 501' Rim to Invert: 9.38' Slack: 2.61" Sump: 2.55" Step Position: 270°

Position	Elev	Angle	Ext. (cw)	Pipe	Pipe OD	Connector	Hole	Horz Size	Up ( )	Offset
Invert 1	491.62'	0°	0"	30" HDPE	35.1"	Hole 38	38"	41.151"	0"	0"
Invert 2	491.67'	92°	57.75"	30" HDPE	35.1"	Hole 38	38"	41.151"	0.625"	0"
Invert 3										
Invert 4										
Invert 5										
Invert 6										
Invert 7										
Invert 8										

RIGHT-SIDE UP VIEW (int. dimensions)

UPSIDE-DOWN VIEW (int. dimensions)

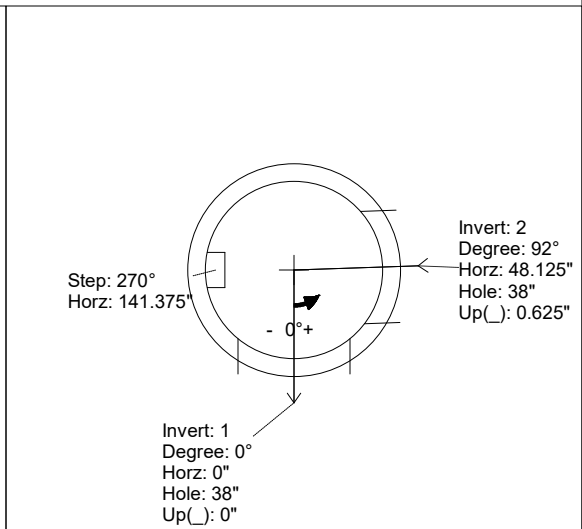
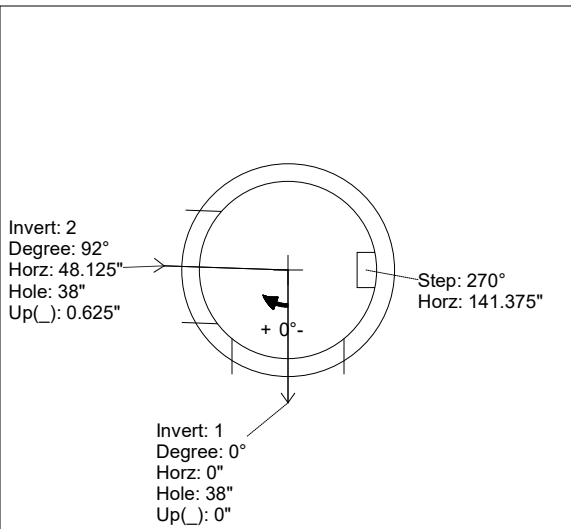
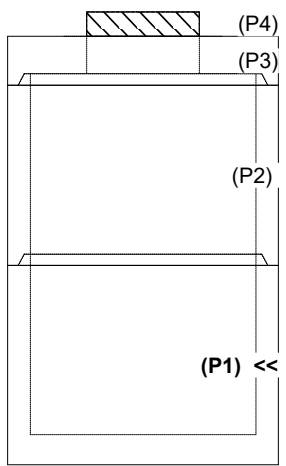

INSIDE WALL DIMENSIONS

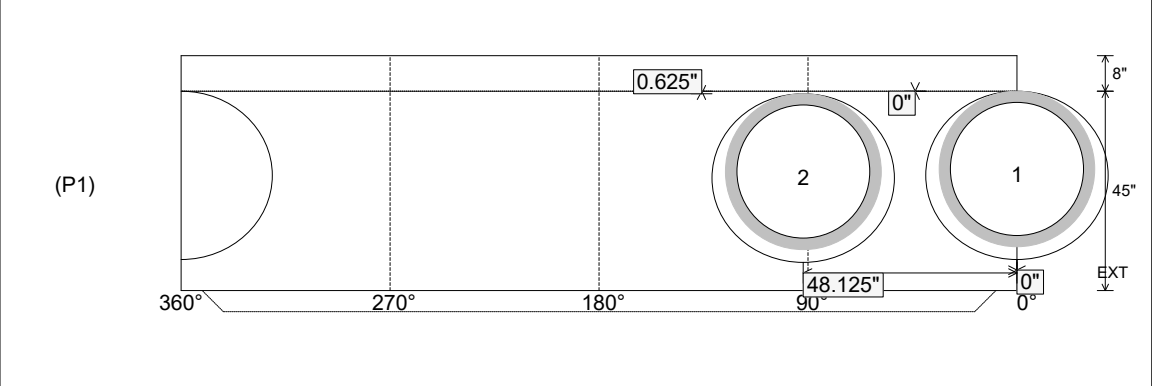

Coating (Int): Coating (Ext):	Seam Up: Tongue Seam Dn: n/a	Wall Thickness: 6" Floor Height: 8"	Height (Int): 45" Height (Ext): 53"	Weight (Net): 6211 lb Volume (Net): 1.59cu.yd
----------------------------------	---------------------------------	--	--	--

Job Name: 26-1077 - Westside Markets of Greensboro Village  
 Job Location: Gallatin, TN  
 Contractor: Cleary Construction, Inc.

Plant: 100  
 3/27/2026 4:33:35 PM

Tech: J. Horsley - F  
 PC: C. Goff



**Structure ID: A6**

**P1 MH060BAVF**

**MH BASE Custom Ht T/n**

- P4) 30" x 36" - CASTING HEIGHT - 6.50"
- P3) 60" - MH FLAT TOP w/30"x36" Hole F/G - 13"
- P2) 60" - MH RISER T/G - 48"
- P1) 60" - MH BASE Custom Ht T/n - 45"
- 1) 60" - STORM INVERT CHANNEL - 1/4 HEIGHT**
- 2) 60" - Conseal CS-102 1.00"
- 2) Hole - 38
- 3) Hole - 6
- 8) MH Step ML-10-TDS-NCR - 10"

0 lb  
 2834 lb  
 4968 lb  
 6211 lb  
 1700 lb  
 0 lb  
 0 lb  
 0 lb  
 0 lb  
 0 lb  
 Structure Total: 15714 lb

**Structure Notes:**  
 1. PER ASTM C478 SPECIFICATIONS.  
 2. CONCRETE = 4,000 PSI AT 28 DAYS.  
 3. CASTING SUPPLIED BY OTHERS (JBS 2064 F/G/H - SINGLE CURB INLET).  
  
 REINFORCING PER ASTM A615 (GRADE 60).  
 - TOP SLAB (As .62) #5 BARS AT 6" C.C.E.W..  
 - RISER/WALLS (As .18)  
 - FLOOR (As .37) #5 BARS AT 10" C.C.E.W.

Rim: 501' Rim to Invert: 9.38' Slack: 2.61" Sump: 2.55" Step Position: 270°

Position	Elev	Angle	Ext. (cw)	Pipe	Pipe OD	Connector	Hole	Horz Size	Up (↓)	Offset
Invert 1	491.62'	0°	0"	30" HDPE	35.1"	Hole 38	38"	41.151"	0"	0"
Invert 2	491.67'	92°	57.75"	30" HDPE	35.1"	Hole 38	38"	41.151"	0.625"	0"
Invert 3										
Invert 4										
Invert 5										
Invert 6										
Invert 7										
Invert 8										

RIGHT-SIDE UP VIEW (int. dimensions)

UPSIDE-DOWN VIEW (int. dimensions)

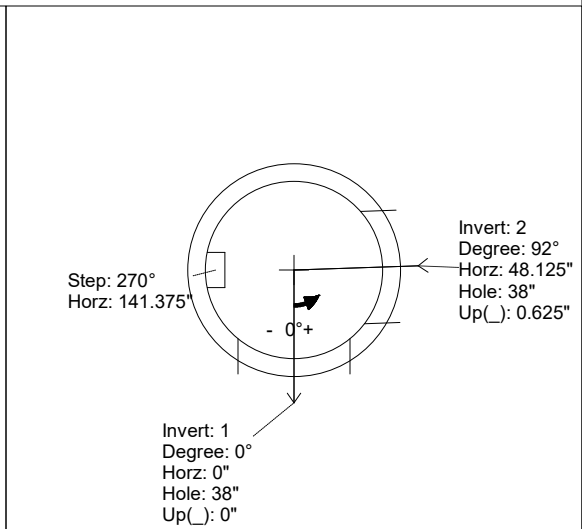
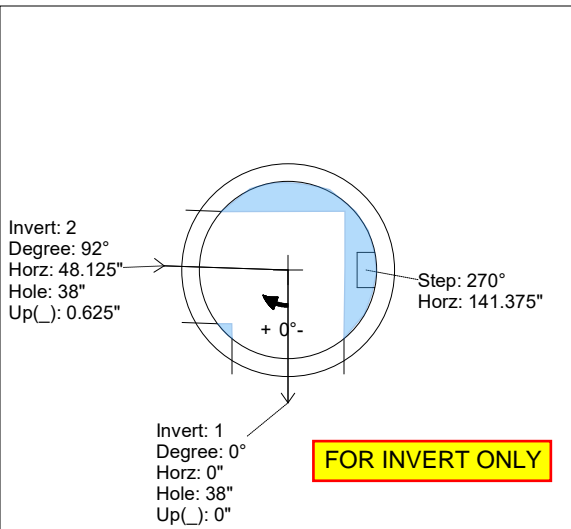
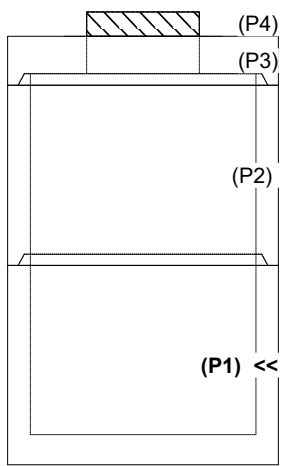

INSIDE WALL DIMENSIONS

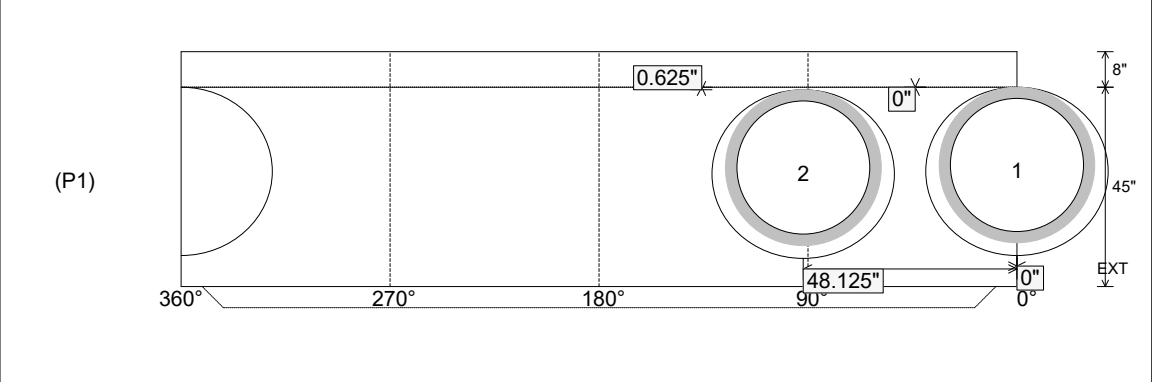

Coating (Int): Coating (Ext):	Seam Up: Tongue Seam Dn: n/a	Wall Thickness: 6" Floor Height: 8"	Height (Int): 45" Height (Ext): 53"	Weight (Net): 6211 lb Volume (Net): 1.59cu.yd
----------------------------------	---------------------------------	--	--	--