

Job Name: 26-1077 - Westside Markets of Greensboro Village  
 Job Location: Gallatin, TN  
 Contractor: Cleary Construction, Inc.

Plant: 100  
 3/27/2026 4:34:11 PM

Tech: J. Horsley - F  
 PC: C. Goff



**Structure ID: A5**

**P2 MH060RS48S**

**MH RISER T/G**

- P4) 36" x 36" - CASTING HEIGHT - 4"
- P3) 60" - MH FLAT TOP w/36"x36" Hole F/G - 13"
- P2) 60" - MH RISER T/G - 48"
- P1) 60" - MH BASE Custom Ht T/n - 51"
- 1) 60" - STORM INVERT CHANNEL - 1/4 HEIGHT
- 2) 60" - Conseal CS-102 1.00"
- 1) 36" x 36" - Conseal CS-102 1.00"
- 1) Hole - 44
- 1) Hole - 38
- 4) Hole - 6
- 8) MH Step ML-10-TDS-NCR - 10"

0 lb  
 2134 lb  
 4954 lb  
 6606 lb  
 1700 lb  
 0 lb  
 0 lb  
 0 lb  
 0 lb  
 0 lb  
 0 lb  
 0 lb  
 Structure Total: 15393 lb

**Structure Notes:**  
 1. PER ASTM C478 SPECIFICATIONS.  
 2. CONCRETE = 4,000 PSI AT 28 DAYS.  
 3. CASTING SUPPLIED BY OTHERS (JBS 4073 F/G).  
  
 REINFORCING PER ASTM A615 (GRADE 60).  
 - TOP SLAB (As .62) #5 BARS AT 6" C.C.E.W..  
 - RISER/WALLS (As .18)  
 - FLOOR (As .37) #5 BARS AT 10" C.C.E.W.

Rim: 500.75' Rim to Invert: 9.68' Slack: 3.01" Sump: 2.85" Step Position: 45°

Position	Elev	Angle	Ext. (cw)	Pipe	Pipe OD	Connector	Hole	Horz Size	Up ( )	Offset
Invert 1										
Invert 2										
Invert 3	498.25'	0°	0"	4" HDPE (perf pipe)	4.8"	Hole 6	6"	6.01"	32.875"	0"
Invert 4	498.25'	90°	56.5"	4" HDPE (perf pipe)	4.8"	Hole 6	6"	6.01"	32.875"	0"
Invert 5	498.25'	180°	113.125"	4" HDPE (perf pipe)	4.8"	Hole 6	6"	6.01"	32.875"	0"
Invert 6	498.25'	270°	169.625"	4" HDPE (perf pipe)	4.8"	Hole 6	6"	6.01"	32.875"	0"
Invert 7										
Invert 8										

**RIGHT-SIDE UP VIEW (int. dimensions)**

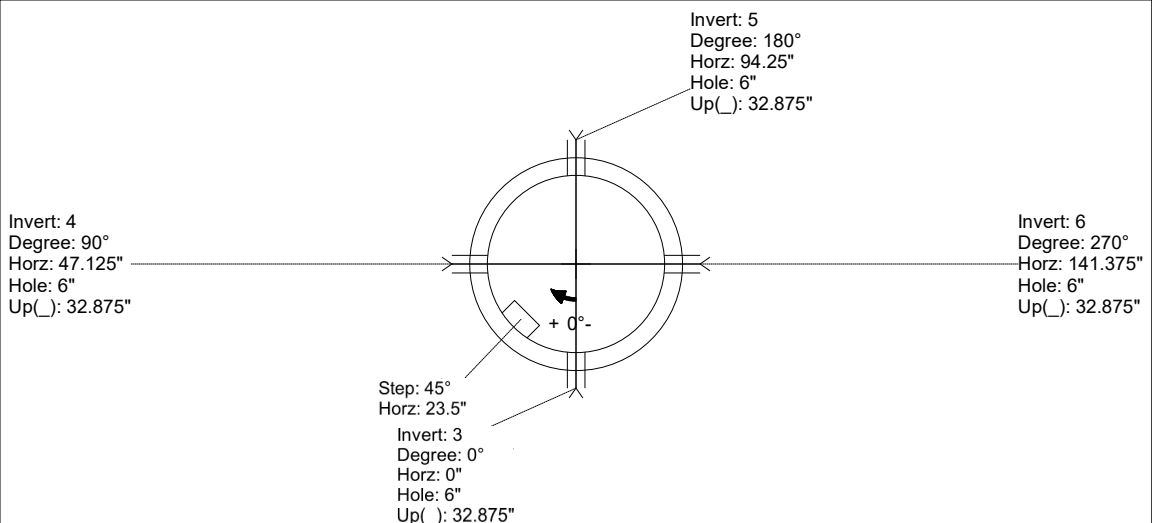
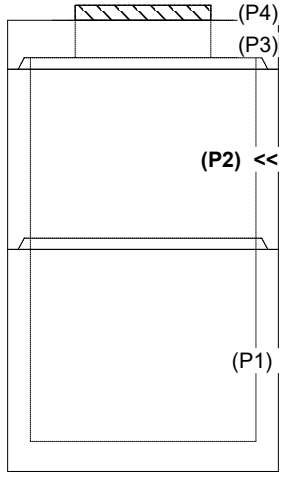

**INSIDE WALL DIMENSIONS**

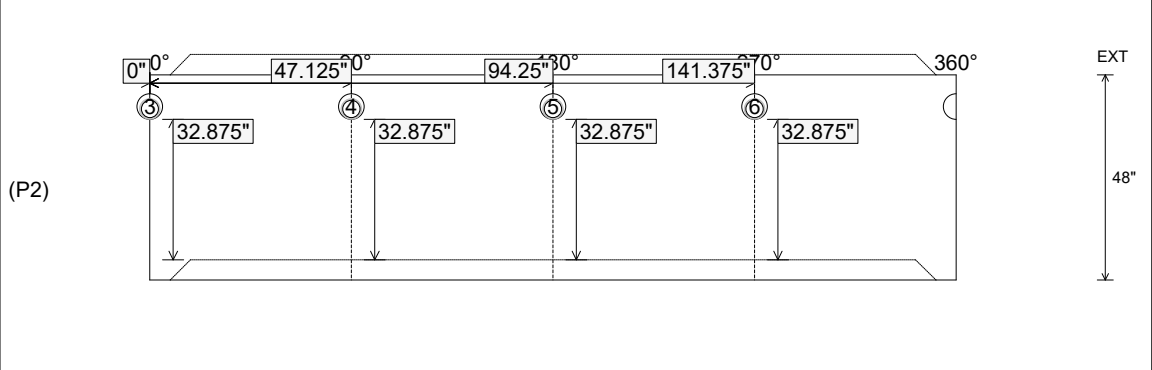

Coating (Int): Coating (Ext):	Seam Up: Tongue Seam Dn: Groove	Wall Thickness: 6" Floor Height: 0"	Height (Int): 48" Height (Ext): 48"	Weight (Net): 4954 lb Volume (Net): 1.26cu.yd
----------------------------------	------------------------------------	--	--	--