

Job Name: 26-1077 - Westside Markets of Greensboro Village
 Job Location: Gallatin, TN
 Contractor: Cleary Construction, Inc.

Plant: 100

3/27/2026 4:33:34 PM

Tech: J. Horsley - F

PC: C. Goff



Structure ID: A5

P1 MH060BAVF

MH BASE Custom Ht T/n

- P4) 36" x 36" - CASTING HEIGHT - 4"
- P3) 60" - MH FLAT TOP w/36"x36" Hole F/G - 13"
- P2) 60" - MH RISER T/G - 48"
- P1) 60" - MH BASE Custom Ht T/n - 51"
- 1) 60" - STORM INVERT CHANNEL - 1/4 HEIGHT
- 2) 60" - Conseal CS-102 1.00"
- 1) 36" x 36" - Conseal CS-102 1.00"
- 1) Hole - 44
- 1) Hole - 38
- 4) Hole - 6
- 8) MH Step ML-10-TDS-NCR - 10"

- 0 lb
- 2134 lb
- 4954 lb
- 6606 lb
- 1700 lb
- 0 lb
- 0 lb
- 0 lb
- 0 lb
- 0 lb
- 0 lb

Structure Total: 15393 lb

Structure Notes:

1. PER ASTM C478 SPECIFICATIONS.
2. CONCRETE = 4,000 PSI AT 28 DAYS.
3. CASTING SUPPLIED BY OTHERS (JBS 4073 F/G).

REINFORCING PER ASTM A615 (GRADE 60).
 - TOP SLAB (As .62) #5 BARS AT 6" C.C.E.W..
 - RISER/WALLS (As .18)
 - FLOOR (As .37) #5 BARS AT 10" C.C.E.W.

Rim: 500.75' Rim to Invert: 9.68' Slack: 3.01" Sump: 2.85" Step Position: 45°

Position	Elev	Angle	Ext. (cw)	Pipe	Pipe OD	Connector	Hole	Horz Size	Up (↓)	Offset
Invert 1	491.07'	0°	0"	36" HDPE	41.7"	Hole 44	44"	49.393"	0"	0"
Invert 2	491.12'	259°	162.75"	30" HDPE	35.1"	Hole 38	38"	41.151"	0.875"	0"
Invert 3										
Invert 4										
Invert 5										
Invert 6										
Invert 7										
Invert 8										

RIGHT-SIDE UP VIEW (int. dimensions)

UPSIDE-DOWN VIEW (int. dimenions)

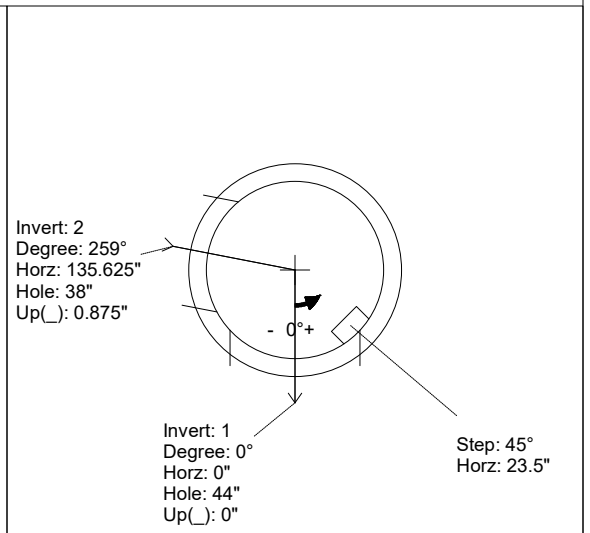
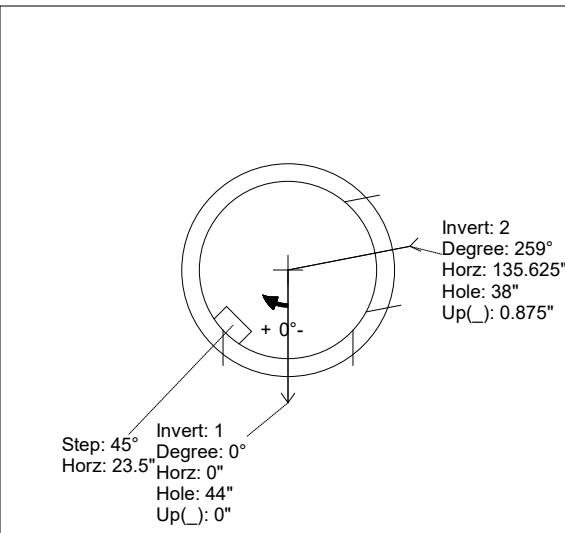
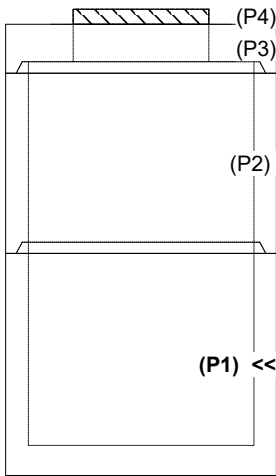

INSIDE WALL DIMENSIONS

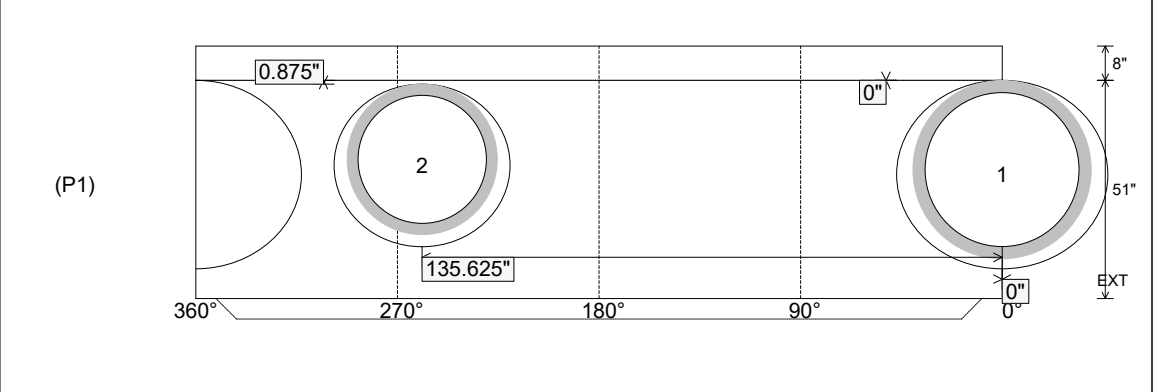

Coating (Int): Coating (Ext):	Seam Up: Tongue Seam Dn: n/a	Wall Thickness: 6" Floor Height: 8"	Height (Int): 51" Height (Ext): 59"	Weight (Net): 6606 lb Volume (Net): 1.69cu.yd
----------------------------------	---------------------------------	--	--	--

Job Name: 26-1077 - Westside Markets of Greensboro Village
 Job Location: Gallatin, TN
 Contractor: Cleary Construction, Inc.

Plant: 100
 3/27/2026 4:33:34 PM

Tech: J. Horsley - F
 PC: C. Goff



Structure ID: A5

P1 MH060BAVF

MH BASE Custom Ht T/n

- P4) 36" x 36" - CASTING HEIGHT - 4"
- P3) 60" - MH FLAT TOP w/36"x36" Hole F/G - 13"
- P2) 60" - MH RISER T/G - 48"
- P1) 60" - MH BASE Custom Ht T/n - 51"
- 1) 60" - STORM INVERT CHANNEL - 1/4 HEIGHT
- 2) 60" - Conseal CS-102 1.00"
- 1) 36" x 36" - Conseal CS-102 1.00"
- 1) Hole - 44
- 1) Hole - 38
- 4) Hole - 6
- 8) MH Step ML-10-TDS-NCR - 10"

0 lb
 2134 lb
 4954 lb
 6606 lb
 1700 lb
 0 lb
 0 lb
 0 lb
 0 lb
 0 lb
 0 lb
 0 lb
 0 lb
 Structure Total: 15393 lb

Structure Notes:

1. PER ASTM C478 SPECIFICATIONS.
2. CONCRETE = 4,000 PSI AT 28 DAYS.
3. CASTING SUPPLIED BY OTHERS (JBS 4073 F/G).

REINFORCING PER ASTM A615 (GRADE 60).
 - TOP SLAB (As .62) #5 BARS AT 6" C.C.E.W..
 - RISER/WALLS (As .18)
 - FLOOR (As .37) #5 BARS AT 10" C.C.E.W.

Rim: 500.75' Rim to Invert: 9.68' Slack: 3.01" Sump: 2.85" Step Position: 45°

Position	Elev	Angle	Ext. (cw)	Pipe	Pipe OD	Connector	Hole	Horz Size	Up (↓)	Offset
Invert 1	491.07'	0°	0"	36" HDPE	41.7"	Hole 44	44"	49.393"	0"	0"
Invert 2	491.12'	259°	162.75"	30" HDPE	35.1"	Hole 38	38"	41.151"	0.875"	0"
Invert 3										
Invert 4										
Invert 5										
Invert 6										
Invert 7										
Invert 8										

RIGHT-SIDE UP VIEW (int. dimensions)

UPSIDE-DOWN VIEW (int. dimenions)

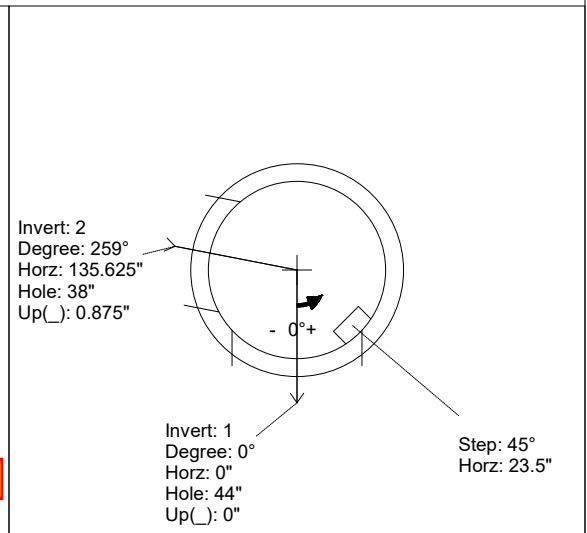
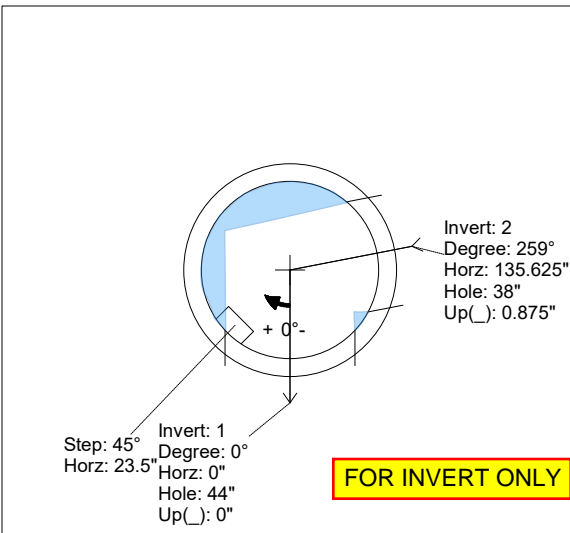
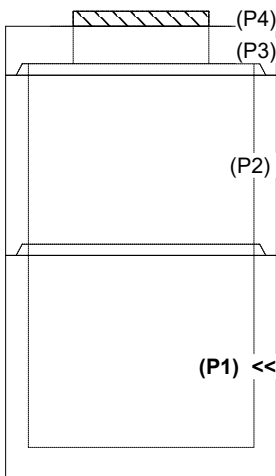

INSIDE WALL DIMENSIONS

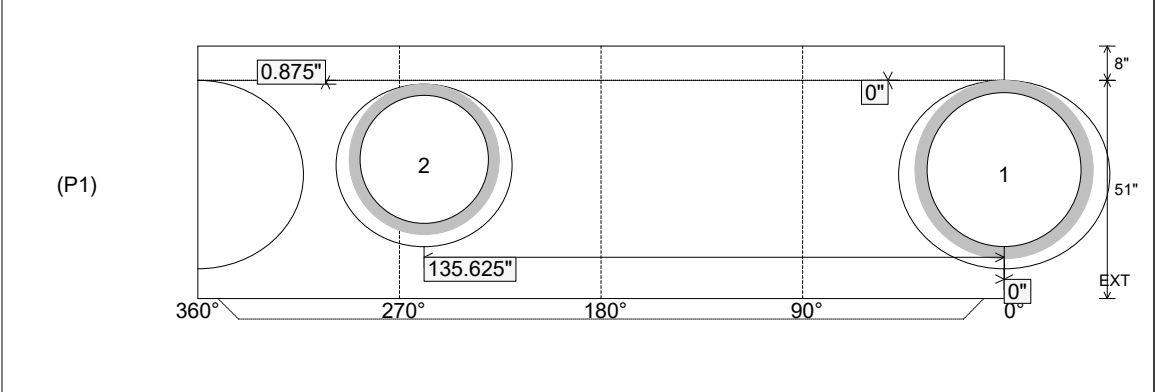

Coating (Int): Coating (Ext):	Seam Up: Tongue Seam Dn: n/a	Wall Thickness: 6" Floor Height: 8"	Height (Int): 51" Height (Ext): 59"	Weight (Net): 6606 lb Volume (Net): 1.69cu.yd
----------------------------------	---------------------------------	--	--	--