

Job Name: 26-1077 - Westside Markets of Greensboro Village  
 Job Location: Gallatin, TN  
 Contractor: Cleary Construction, Inc.

Plant: 100  
 3/27/2026 4:33:32 PM

Tech: J. Horsley - F  
 PC: C. Goff



**Structure ID: A3**

**P1 MH060BA60**

**MH BASE T/n**

- P4) 30" x 36" - CASTING HEIGHT - 6.50"
- P3) 60" - MH FLAT TOP w/30"x36" Hole F/G - 13"
- P2) 60" - MH RISER T/G - 60"
- P1) 60" - MH BASE T/n - 60"
- 1) 60" - STORM INVERT CHANNEL - 1/4 HEIGHT
- 2) 60" - Conseal CS-102 1.00"
- 2) Hole - 44
- 3) Hole - 6
- 10) MH Step ML-10-TDS-NCR - 10"

0 lb  
 2834 lb  
 6221 lb  
 7314 lb  
 1700 lb  
 0 lb  
 0 lb  
 0 lb  
 0 lb  
 0 lb  
 Structure Total: 18069 lb

**Structure Notes:**  
 1. PER ASTM C478 SPECIFICATIONS.  
 2. CONCRETE = 4,000 PSI AT 28 DAYS.  
 3. CASTING SUPPLIED BY OTHERS (JBS 2064 F/G/H - SINGLE CURB INLET).

REINFORCING PER ASTM A615 (GRADE 60).  
 - TOP SLAB (As .62) #5 BARS AT 6" C.C.E.W..  
 - RISER/WALLS (As .18)  
 - FLOOR (As .37) #5 BARS AT 10" C.C.E.W.

Rim: 501.1' Rim to Invert: 11.64' Slack: 3.03" Sump: 2.85" Step Position: 270°

| Position | Elev    | Angle | Ext. (cw) | Pipe     | Pipe OD | Connector | Hole | Horz Size | Up (↓) | Offset |
|----------|---------|-------|-----------|----------|---------|-----------|------|-----------|--------|--------|
| Invert 1 | 489.46' | 0°    | 0"        | 36" HDPE | 41.7"   | Hole 44   | 44"  | 49.393"   | 0"     | 0"     |
| Invert 2 | 489.51' | 171°  | 107.5"    | 36" HDPE | 41.7"   | Hole 44   | 44"  | 49.393"   | 0.625" | 0"     |
| Invert 3 |         |       |           |          |         |           |      |           |        |        |
| Invert 4 |         |       |           |          |         |           |      |           |        |        |
| Invert 5 |         |       |           |          |         |           |      |           |        |        |
| Invert 6 |         |       |           |          |         |           |      |           |        |        |
| Invert 7 |         |       |           |          |         |           |      |           |        |        |
| Invert 8 |         |       |           |          |         |           |      |           |        |        |

RIGHT-SIDE UP VIEW (int. dimensions)

UPSIDE-DOWN VIEW (int. dimensions)

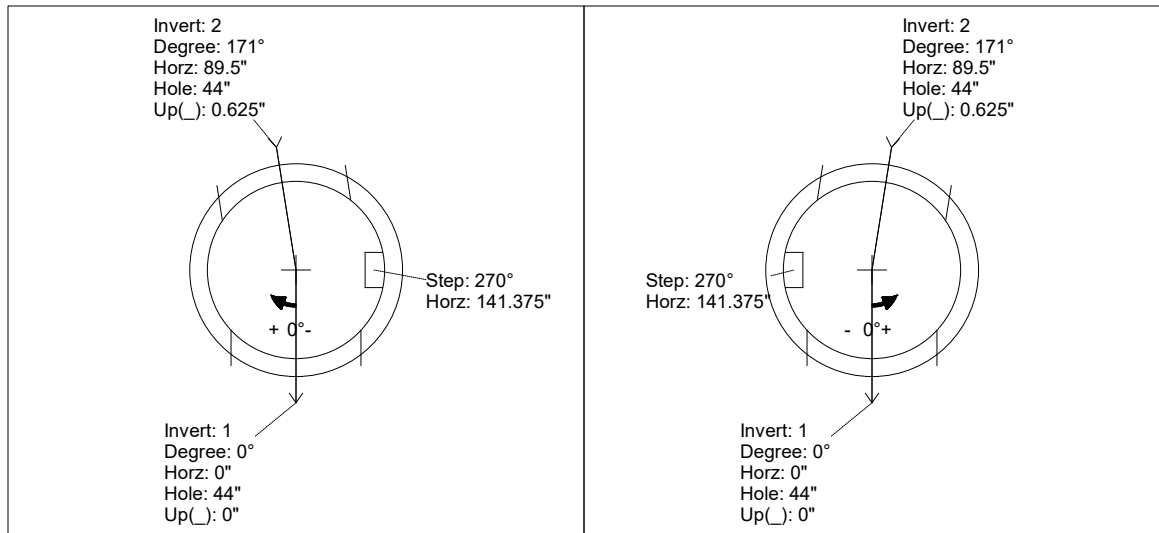

INSIDE WALL DIMENSIONS

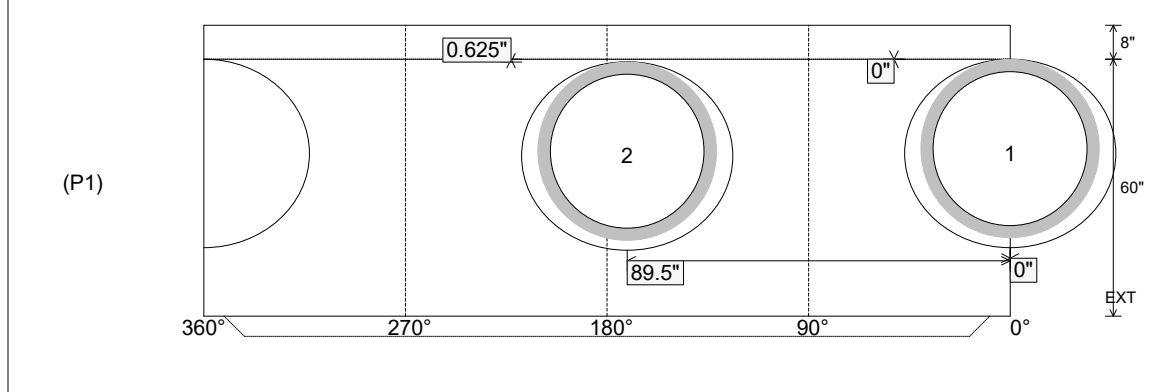

Coating (Int):  
 Coating (Ext):

Seam Up: Tongue  
 Seam Dn: n/a

Wall Thickness: 6"  
 Floor Height: 8"

Height (Int): 60"  
 Height (Ext): 68"

Weight (Net): 7314 lb  
 Volume (Net): 1.87cu.yd

Job Name: 26-1077 - Westside Markets of Greensboro Village  
 Job Location: Gallatin, TN  
 Contractor: Cleary Construction, Inc.

Plant: 100  
 3/27/2026 4:33:32 PM

Tech: J. Horsley - F  
 PC: C. Goff



**Structure ID: A3**

**P1 MH060BA60**

**MH BASE T/n**

- P4) 30" x 36" - CASTING HEIGHT - 6.50"
- P3) 60" - MH FLAT TOP w/30"x36" Hole F/G - 13"
- P2) 60" - MH RISER T/G - 60"
- P1) 60" - MH BASE T/n - 60"
- 1) 60" - STORM INVERT CHANNEL - 1/4 HEIGHT**
- 2) 60" - Conseal CS-102 1.00"
- 2) Hole - 44
- 3) Hole - 6
- 10) MH Step ML-10-TDS-NCR - 10"

0 lb  
 2834 lb  
 6221 lb  
 7314 lb  
 1700 lb  
 0 lb  
 0 lb  
 0 lb  
 0 lb  
 0 lb  
 Structure Total: 18069 lb

**Structure Notes:**  
 1. PER ASTM C478 SPECIFICATIONS.  
 2. CONCRETE = 4,000 PSI AT 28 DAYS.  
 3. CASTING SUPPLIED BY OTHERS (JBS 2064 F/G/H - SINGLE CURB INLET).

REINFORCING PER ASTM A615 (GRADE 60).  
 - TOP SLAB (As .62) #5 BARS AT 6" C.C.E.W..  
 - RISER/WALLS (As .18)  
 - FLOOR (As .37) #5 BARS AT 10" C.C.E.W.

Rim: 501.1' Rim to Invert: 11.64' Slack: 3.03" Sump: 2.85" Step Position: 270°

| Position | Elev    | Angle | Ext. (cw) | Pipe     | Pipe OD | Connector | Hole | Horz Size | Up (↓) | Offset |
|----------|---------|-------|-----------|----------|---------|-----------|------|-----------|--------|--------|
| Invert 1 | 489.46' | 0°    | 0"        | 36" HDPE | 41.7"   | Hole 44   | 44"  | 49.393"   | 0"     | 0"     |
| Invert 2 | 489.51' | 171°  | 107.5"    | 36" HDPE | 41.7"   | Hole 44   | 44"  | 49.393"   | 0.625" | 0"     |
| Invert 3 |         |       |           |          |         |           |      |           |        |        |
| Invert 4 |         |       |           |          |         |           |      |           |        |        |
| Invert 5 |         |       |           |          |         |           |      |           |        |        |
| Invert 6 |         |       |           |          |         |           |      |           |        |        |
| Invert 7 |         |       |           |          |         |           |      |           |        |        |
| Invert 8 |         |       |           |          |         |           |      |           |        |        |

RIGHT-SIDE UP VIEW (int. dimensions)

UPSIDE-DOWN VIEW (int. dimensions)

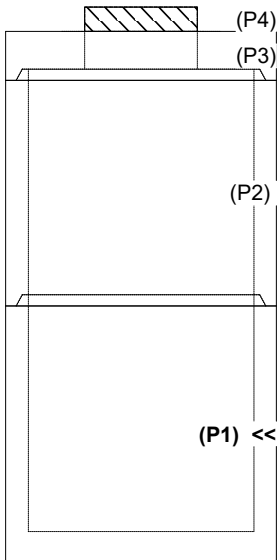
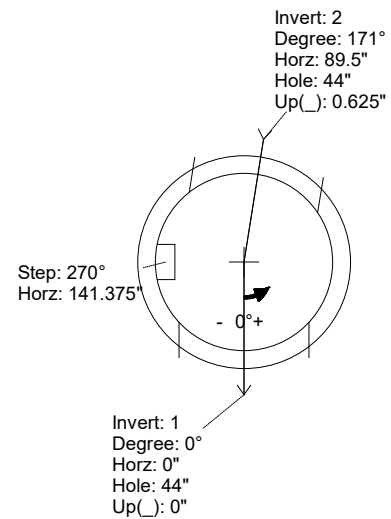
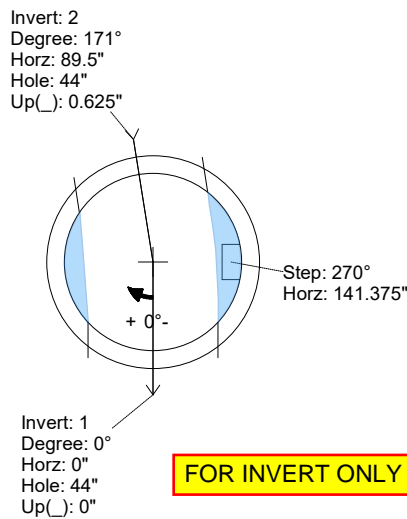

INSIDE WALL DIMENSIONS

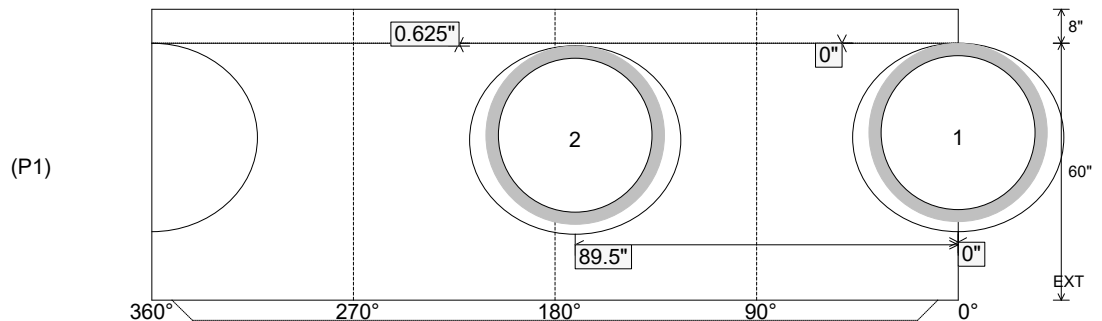

Coating (Int):  
 Coating (Ext):

Seam Up: Tongue  
 Seam Dn: n/a

Wall Thickness: 6"  
 Floor Height: 8"

Height (Int): 60"  
 Height (Ext): 68"

Weight (Net): 7314 lb  
 Volume (Net): 1.87cu.yd