

Job Name: 26-1035 Sixty-Nine Gardens Manholes
 Job Location: Savannah, TN
 Contractor: Summertown Metals

Plant: Beaver Dam
 2/20/2026 10:32:29 AM

Tech: S. Felletter
 PC: T. Lewis



Structure ID: 3 (4)

P3 GR3CDARED

GRADE RING w/ConBlock-CDA Red F/F

P4) 24" - CASTING HEIGHT - 7"	0 lb
P3) 24" - GRADE RING w/ConBlock-CDA Red F/F - 3"	202 lb
P2) 48" - ECC CONE w/ 24" HOLE, w/ConBlock-CDA Red F/G - 42"	3116 lb
P1) 48" - MH BASE w/ConBlock-CDA Red T/n - 30"	3282 lb
1) JOINT WRAP PRIMER - CONSEAL CS-75 (1 gal.)	0 lb
1) JOINT WRAP - 0.065"x6"x50' CONSEAL CS212	0 lb
1) 48" - MH INVERT CHANNEL w/ConBlock-CDA Red - FULL HEIGHT	1440 lb
1) CASTING - HOE MC-375 F/C Sanitary	271 lb
1) 48" - Conseal CS-102 1.00" (Double)	0 lb
3) PSX - 12-08 NYLO	24 lb
6) MH Step ML-10-TDS-NCR - 10"	0 lb
89.39 SqFt) CS-55 BLACK ACRYLLIC [EXT]	0 lb
Structure Total:	8336 lb

Structure Notes:
 1. PER ASTM C478 SPECIFICATIONS.
 2. CONCRETE = 4,000 PSI AT 28 DAYS.
 3. ADMIXTURE = CONBLOCK CDA RED.
 4. CASTING HOE MC-375 SANITARY BY ICAST.

REINFORCING PER ASTM A615 (GRADE 60).
 - CONE (As .12)
 - RISER/WALLS (As .12)
 - FLOOR (As .31) #5 BARS AT 12" C.C.E.W.

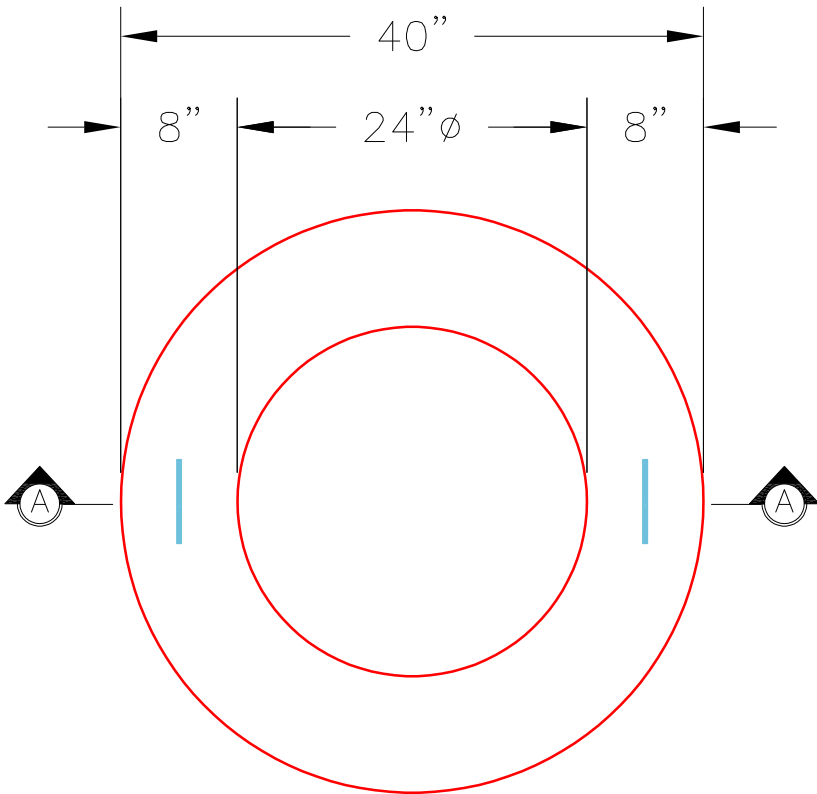

PLAN VIEW

- NOTES:**
- GRADE RINGS MEET OR EXCEED THE FOLLOWING SPECIFICATIONS
 -CONCRETE: 4,000 PSI @ 28 DAYS
 -REINFORCING: (1) #3 HOOP CENTERED (GRADE 60)
 - WEIGHT: 3" 202 LBS.
 - ADMIXTURE: CONBLOCK-CDA RED

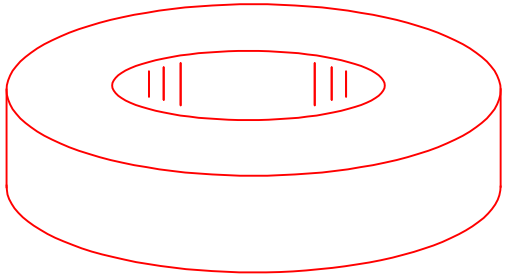

ISOMETRIC VIEW

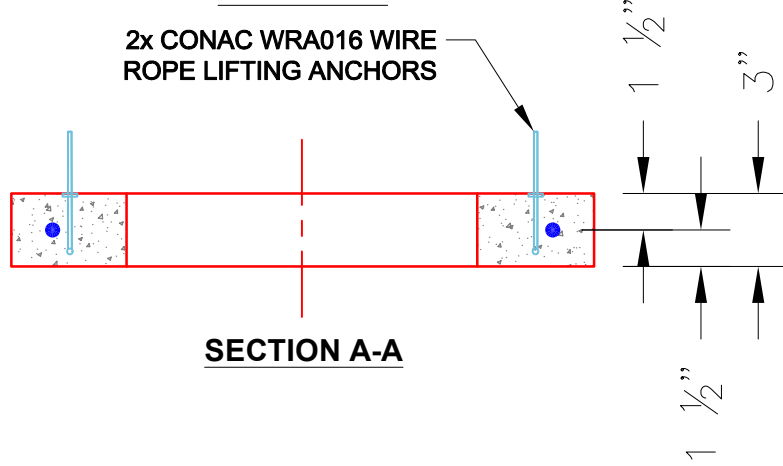

SECTION A-A

Coating (Int): Coating (Ext): CS-55 BLACK ACRYLLIC	Seam Up: Flat Seam Dn: Flat	Wall Thickness: 8"	Height (Ext): 3"	Weight (Net): 202 lb Volume (Net): 0.05cu.yd
---	--------------------------------	--------------------	------------------	---