

Job Name: 25-4789 Garrison Gardens Utilities
 Job Location: Bowling Green, KY
 Contractor: Scott & Ritter, Inc.

Plant: Beaver Dam
 4/16/2026 10:58:20 AM

Tech: S. Felletter
 PC: C. Goff



Structure ID: san7-4 (26)

P1 MH048BA24

MH BASE T/n

P4) 24" - CASTING HEIGHT - 7"	0 lb
P3) 24" - GRADE RING F/F - 4"	270 lb
P2) 48" - MH FLAT TOP w/ 24" ECC Hole F/G - 12"	1561 lb
P1) 48" - MH BASE T/n - 24"	2890 lb
1) 48" - MH INVERT CHANNEL - FULL HEIGHT	1440 lb
1) Conseal CS-102 1.00" (Single)	0 lb
1) JOINT WRAP - 0.065"x6"x50' CONSEAL CS212	0 lb
1) JOINT WRAP PRIMER - CONSEAL CS-75 (1 gal.)	0 lb
1) CASTING - HOE MC-375 F/C Sanitary	271 lb
1) 48" - Conseal CS-102 1.00"	0 lb
2) PSX - 12-08 NYLO	16 lb
1) PSX - 8QRS-S NYLO	6 lb
1) MH Step ML-10-TDS-NCR - 10"	0 lb
Structure Total:	6454 lb

Structure Notes:
 1. HOE MC-375 F/C SANITARY PROVIDED BY ICAST
 2. PER ASTM C478 SPECIFICATIONS.
 3. CONCRETE = 4,000 PSI AT 28 DAYS.
 4. REINFORCING PER ASTM A615 (GRADE 60).
 - TOP SLAB (As .62) #5 BARS AT 6" C.C.E.W.
 - RISER/WALLS (As .12)
 - FLOOR (As .31) #5 BARS AT 12" C.C.E.W.
 5. DOUBLE PIPE BANDS REQUIRED FOR ALL BOOTS.

Rim: 524.99' Rim to Invert: 3.85' Slack: 1.2" Sump: 2" Step Position: 0°

Position	Elev	Angle	Ext. (cw)	Pipe	Pipe OD	Connector	Hole	Horz Size	Up ()	Offset
Invert 1	521.14'	0°	0"	8" PVC SDR26	8.5"	PSX 12-08 NYLO	12"	12.129"	0"	0"
Invert 2	521.24'	180°	91.106"	8" PVC SDR26	8.5"	PSX 12-08 NYLO	12"	12.129"	1.2"	0"
Invert 3	521.34'	270°	136.659"	4" PVC SDR26	4.25"	PSX 8QRS-S NYLO	8"	8.038"	2.4"	0"
Invert 4										
Invert 5										
Invert 6										
Invert 7										
Invert 8										

RIGHT-SIDE UP VIEW (int. dimensions)

UPSIDE-DOWN VIEW (int. dimensions)

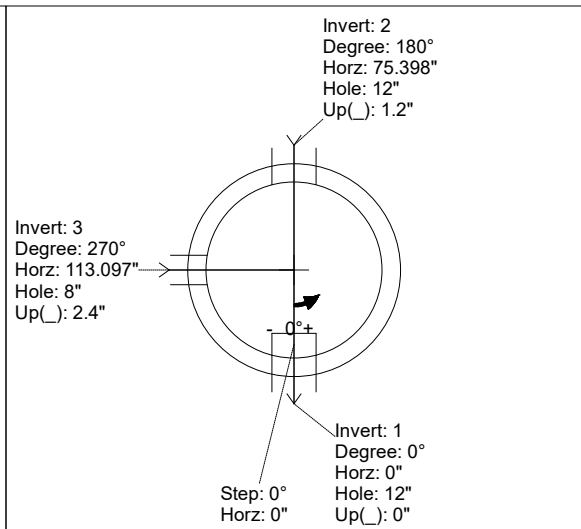
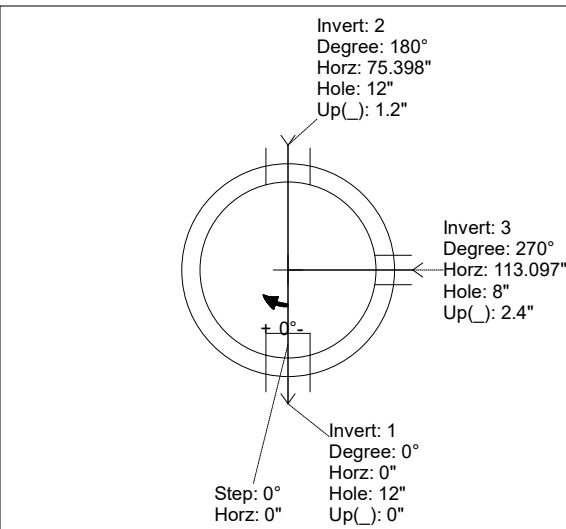
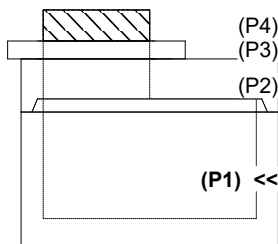

INSIDE WALL DIMENSIONS

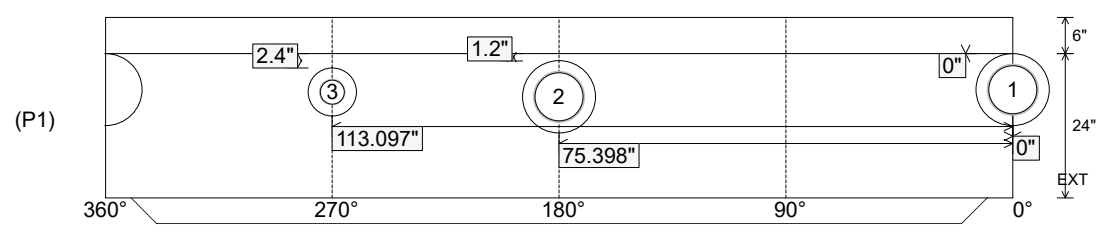

Coating (Int): Coating (Ext):	Seam Up: Tongue Seam Dn: n/a	Wall Thickness: 5" Floor Height: 6"	Height (Int): 24" Height (Ext): 30"	Weight (Net): 2890 lb Volume (Net): 0.74cu.yd
----------------------------------	---------------------------------	--	--	--

Job Name: 25-4789 Garrison Gardens Utilities
 Job Location: Bowling Green, KY
 Contractor: Scott & Ritter, Inc.

Plant: Beaver Dam

Tech: S. Felletter

4/16/2026 10:58:20 AM

PC: C. Goff



Structure ID: san7-4 (26)

P1 MH048BA24

MH BASE T/n

- P4) 24" - CASTING HEIGHT - 7"
- P3) 24" - GRADE RING F/F - 4"
- P2) 48" - MH FLAT TOP w/ 24" ECC Hole F/G - 12"
- P1) 48" - MH BASE T/n - 24"
- 1) 48" - MH INVERT CHANNEL - FULL HEIGHT
- 1) Conseal CS-102 1.00" (Single)
- 1) JOINT WRAP - 0.065"x6"x50' CONSEAL CS212
- 1) JOINT WRAP PRIMER - CONSEAL CS-75 (1 gal.)
- 1) CASTING - HOE MC-375 F/C Sanitary
- 1) 48" - Conseal CS-102 1.00"
- 2) PSX - 12-08 NYLO
- 1) PSX - 8QRS-S NYLO
- 1) MH Step ML-10-TDS-NCR - 10"

- 0 lb
- 270 lb
- 1561 lb
- 2890 lb
- 1440 lb
- 0 lb
- 0 lb
- 0 lb
- 0 lb
- 271 lb
- 0 lb
- 16 lb
- 6 lb
- 0 lb

Structure Notes:

1. HOE MC-375 F/C SANITARY PROVIDED BY ICAST
2. PER ASTM C478 SPECIFICATIONS.
3. CONCRETE = 4,000 PSI AT 28 DAYS.
4. REINFORCING PER ASTM A615 (GRADE 60).
 - TOP SLAB (As .62) #5 BARS AT 6" C.C.E.W.
 - RISER/WALLS (As .12)
- FLOOR (As .31) #5 BARS AT 12" C.C.E.W.
5. DOUBLE PIPE BANDS REQUIRED FOR ALL BOOTS.

Structure Total: 6454 lb

Invert channel drawing
Full height invert

Rim: 524.99' Rim to Invert: 3.85' Slack: 1.2" Sump: 2" Step Position: 0°

Position	Elev	Angle	Ext. (cw)	Pipe	Pipe OD	Connector	Hole	Horz Size	Up ()	Offset
Invert 1	521.14'	0°	0"	8" PVC SDR26	8.5"	PSX 12-08 NYLO	12"	12.129"	0"	0"
Invert 2	521.24'	180°	91.106"	8" PVC SDR26	8.5"	PSX 12-08 NYLO	12"	12.129"	1.2"	0"
Invert 3	521.34'	270°	136.659"	4" PVC SDR26	4.25"	PSX 8QRS-S NYLO	8"	8.038"	2.4"	0"
Invert 4										
Invert 5										
Invert 6										
Invert 7										
Invert 8										

RIGHT-SIDE UP VIEW (int. dimensions)

UPSIDE-DOWN VIEW (int. dimensions)

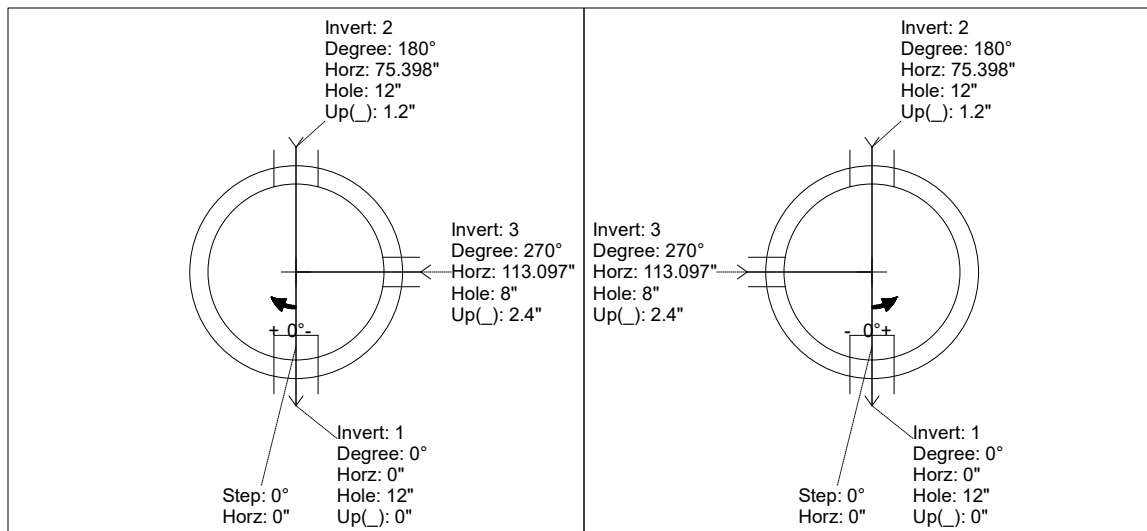
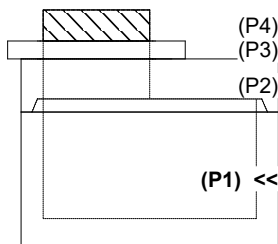

INSIDE WALL DIMENSIONS

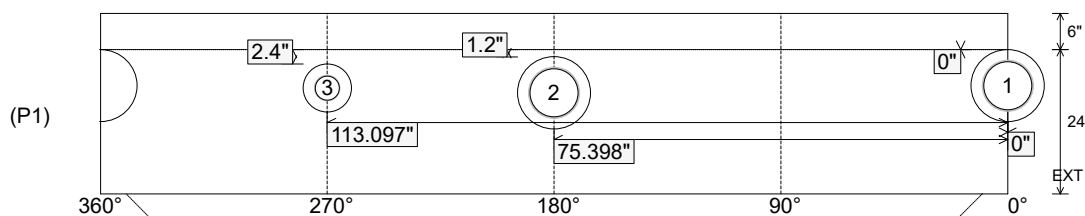

Coating (Int):
Coating (Ext):

Seam Up: Tongue
Seam Dn: n/a

Wall Thickness: 5"
Floor Height: 6"

Height (Int): 24"
Height (Ext): 30"

Weight (Net): 2890 lb
Volume (Net): 0.74cu.yd