

Job Name: 25-4779 - 877786 Founders Point Elem School
 Job Location: Charlestown, IN
 Contractor: Contech Engineering Solutions

Plant: Beaver Dam
 1/6/2026 12:56:26 PM

Tech: J. Coppage
 PC: T. Sekula



Structure ID: 15-CS-6

P2 MH072RSVF

MH RISER Custom Ht

- P4) 30" - CASTING HEIGHT - 4"
- P3) 72" - MH FLAT TOP SPEC. (30" ECC HOLE) - 15"
- P2) 72" - MH RISER Custom Ht - 84"
- P1) 72" - MH BASE w/FLANGE - 24"
- 1) CVSTENCILING
- 1) ASSEMBLY REQUIRED
- 1) SECONDARY POUR
- 2) 72" - Conseal CS-102 1.00"
- 2) Hole - 16

0 lb
 4661 lb
 11969 lb
 8771 lb
 0 lb
 0 lb
 0 lb
 0 lb
 0 lb
 0 lb

 Structure Total: 25401 lb

Structure Notes:
 (4" TALL CASTING PROVIDED BY OTHERS)
 LIFTING ANCHORS TO BE INSTALLED
 ON THE OUTSIDE OF THE STRUCTURE
 ICAST TO INSTALL THE INTERNALS
 CONTECH'S LOGO AS WELL AS THE
 INLET AND THE OUTLET MUST BE
 STENCILED ONTO THE STRUCTURE

Rim: 495.58' Rim to Invert: 5.1' Slack: 3.2' Sump: 69' Step Position:

Position	Elev	Angle	Ext. (cw)	Pipe	Pipe OD	Connector	Hole	Horz Size	Up (_)	Offset
Invert 1	490.48'	0°	-19.68"	12" PVC SDR35	12.5"	Hole 16	16"	19.351"	38"	-19"
Invert 2	490.48'	0°	19.68"	12" PVC SDR35	12.5"	Hole 16	16"	19.351"	38"	19"
Invert 3										
Invert 4										
Invert 5										
Invert 6										
Invert 7										
Invert 8										

RIGHT-SIDE UP VIEW (int. dimensions)

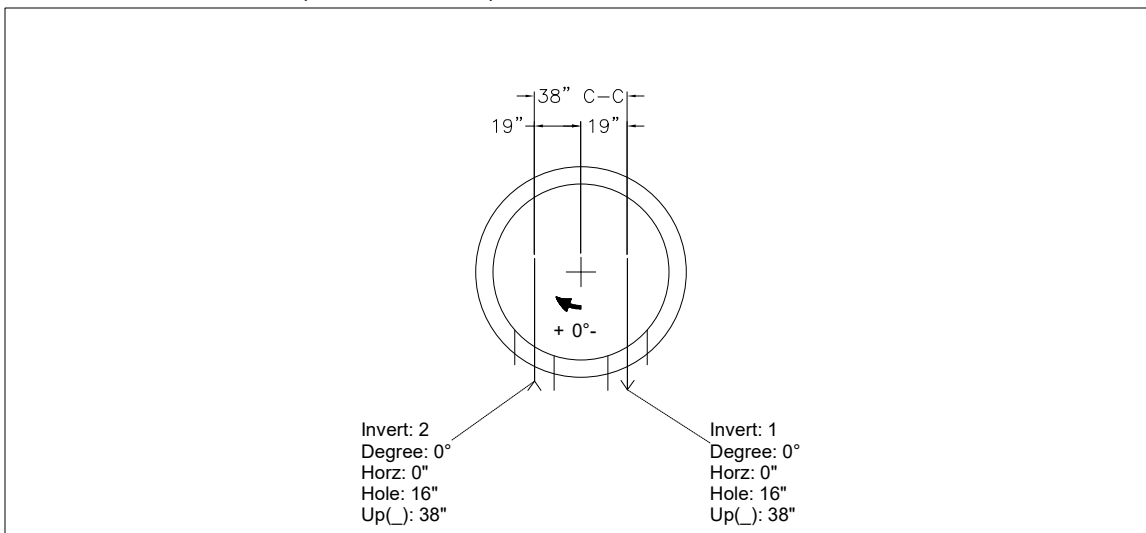
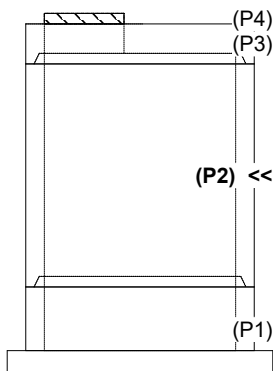

INSIDE WALL DIMENSIONS



Coating (Int):
 Coating (Ext):

Seam Up: Tongue
 Seam Dn: Groove

Wall Thickness: 7"
 Floor Height: 0"

Height (Int): 84"
 Height (Ext): 84"

Weight (Net): 11969 lb
 Volume (Net): 3.06cu.yd