

**Structure ID: 82 (6)**

**P1 BX2424-08BAVF**

**BOX BASE 8inW, 8inF, Variable Ht F/n**

P2) 24" x 24" - CASTING HEIGHT - 4"  
 P1) 24" x 24" - BOX BASE 8inW, 8inF, Variable Ht F/n - 28"  
 1) CASTING - HOE 280T F/G  
 1) 24" x 24" - Conseal CS-102 1.00"  
 2) Hole - 16

|                  |         |
|------------------|---------|
| 0 lb             |         |
| 3210 lb          |         |
| 182 lb           |         |
| 0 lb             |         |
| 0 lb             |         |
| -----            |         |
| Structure Total: | 3392 lb |

Structure Notes:  
 1. PER ASTM C-913 SPECIFICATIONS  
 2. CONCRETE: 4,000 PSI AT 28 DAYS  
 3. REINFORCEMENT: #5 BAR @ 12" C.C. E.W. (GRADE 60) - 2" MIN. REBAR CLEARANCE (TYP)  
 4. NO STORM INVERT  
 5. NO STEPS  
 6. HOE 280T FRAME & GRATE SUPPLIED BY ICAST

Rim: 985.15'      Rim to Invert: 2.7'      Slack: 0.4"      Sump: 0"      Step Position:

| Position | Elev    | Angle | Ext. (cw) | Pipe     | Pipe OD | Connector | Hole | Horz Size | Up ( ) | Offset |
|----------|---------|-------|-----------|----------|---------|-----------|------|-----------|--------|--------|
| Invert 1 | 982.45' | 0°    | 20"       | 12" HDPE | 14.5"   | Hole 16   | 16"  | 16"       | -1.25" | 0"     |
| Invert 2 | 982.45' | 90°   | 20"       | 12" HDPE | 14.5"   | Hole 16   | 16"  | 16"       | -1.25" | 0"     |
| Invert 3 |         |       |           |          |         |           |      |           |        |        |
| Invert 4 |         |       |           |          |         |           |      |           |        |        |
| Invert 5 |         |       |           |          |         |           |      |           |        |        |
| Invert 6 |         |       |           |          |         |           |      |           |        |        |
| Invert 7 |         |       |           |          |         |           |      |           |        |        |
| Invert 8 |         |       |           |          |         |           |      |           |        |        |

RIGHT-SIDE UP VIEW (int. dimensions)

UPSIDE-DOWN VIEW (int. dimensions)

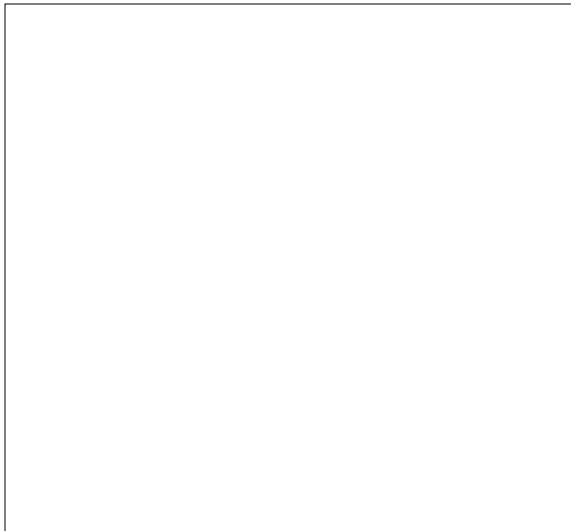
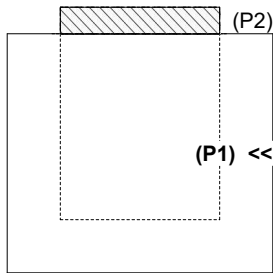

INSIDE WALL DIMENSIONS

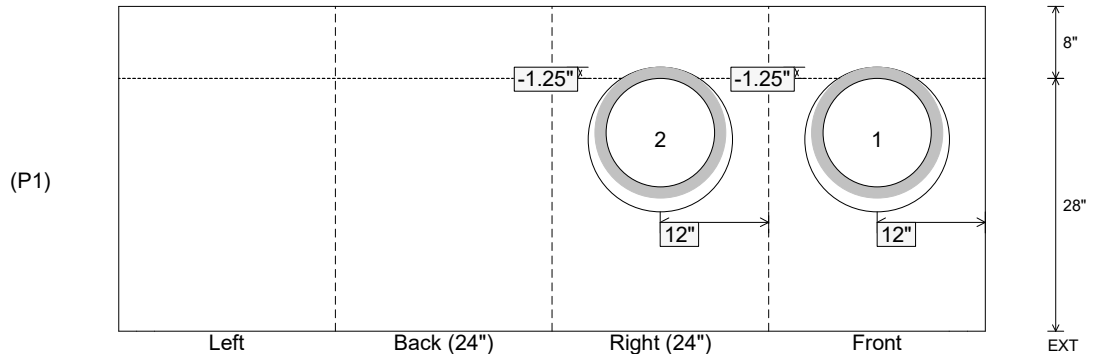

|                                  |                               |  |  |  |
|----------------------------------|-------------------------------|--|--|--|
| Coating (Int):<br>Coating (Ext): | Seam Up: Flat<br>Seam Dn: n/a | Wall Thickness: 8"<br>Floor Height: 8" | Height (Int): 28"<br>Height (Ext): 36" | Weight (Net): 3210 lb<br>Volume (Net): 0.82cu.yd |
|----------------------------------|-------------------------------|--|--|--|