

Job Name: 25-4727- Calista Subdivision (Ph.3)

Job Location: White House, TN

Contractor: Twin States Utilities, Inc.

PC: E. Bradley

TECH: J. Horsley - F

Plant: 100



Structure ID: **MH 9-5 (11)**

Spec: Sanitary

Type: SAN.MH w/ConBlock-CDA Red

Size: 48"

Rim: 795.82'

Invert: 788.75'

Rim to Invert: 7.07'

Sump: 2"

Floor (Top): 788.583'

Floor Height: 6"

Floor (Bot): 788.083'

Overall Height: 7.5'

Slack: 2.84"

Structure Notes:

1. PER ASTM C478 SPECIFICATIONS.
2. CONCRETE = 4,000 PSI AT 28 DAYS.
3. ADMIXTURE = CONBLOCK CDA RED
4. CASTING BY ICAST (JBS 1155 F/C SANITARY)

REINFORCING PER ASTM A615 (GRADE 60).

- CONE (As .12)
- RISER/WALLS (As .12)
- FLOOR (As .31) #5 BARS AT 12" C.C.E.W

STRUCTURE SUMMARY:

P3) 24" - CASTING HEIGHT - 6"	0 lb
P2) 48" - ECC CONE w/ 24" HOLE, w/ConBlock-CDA Red F/G - 42"	3116 lb
P1) 48" - MH BASE w/ConBlock-CDA Red T/n - 36"	3749 lb
1) JOINT WRAP - 0.065"x6"x50' CONSEAL CS212	0 lb
1) JOINT WRAP PRIMER - CONSEAL CS-75 (1 gal.)	0 lb
1) ADMIXTURE CONBLOCK CDA RED	0 lb
1) 48" - MH INVERT CHANNEL OVERSIZED w/ConBlock-CDA Red - FULL HEIGHT	1440 lb
1) CASTING - JBS 1155 F/C SANITARY	250 lb
1) 48" - Conseal CS-102 1.00" (Double)	0 lb
2) PSX - 12-08 NYLO	16 lb
7) MH Step ML-10-TDS-NCR - 10"	0 lb
Structure Total:	8572 lb

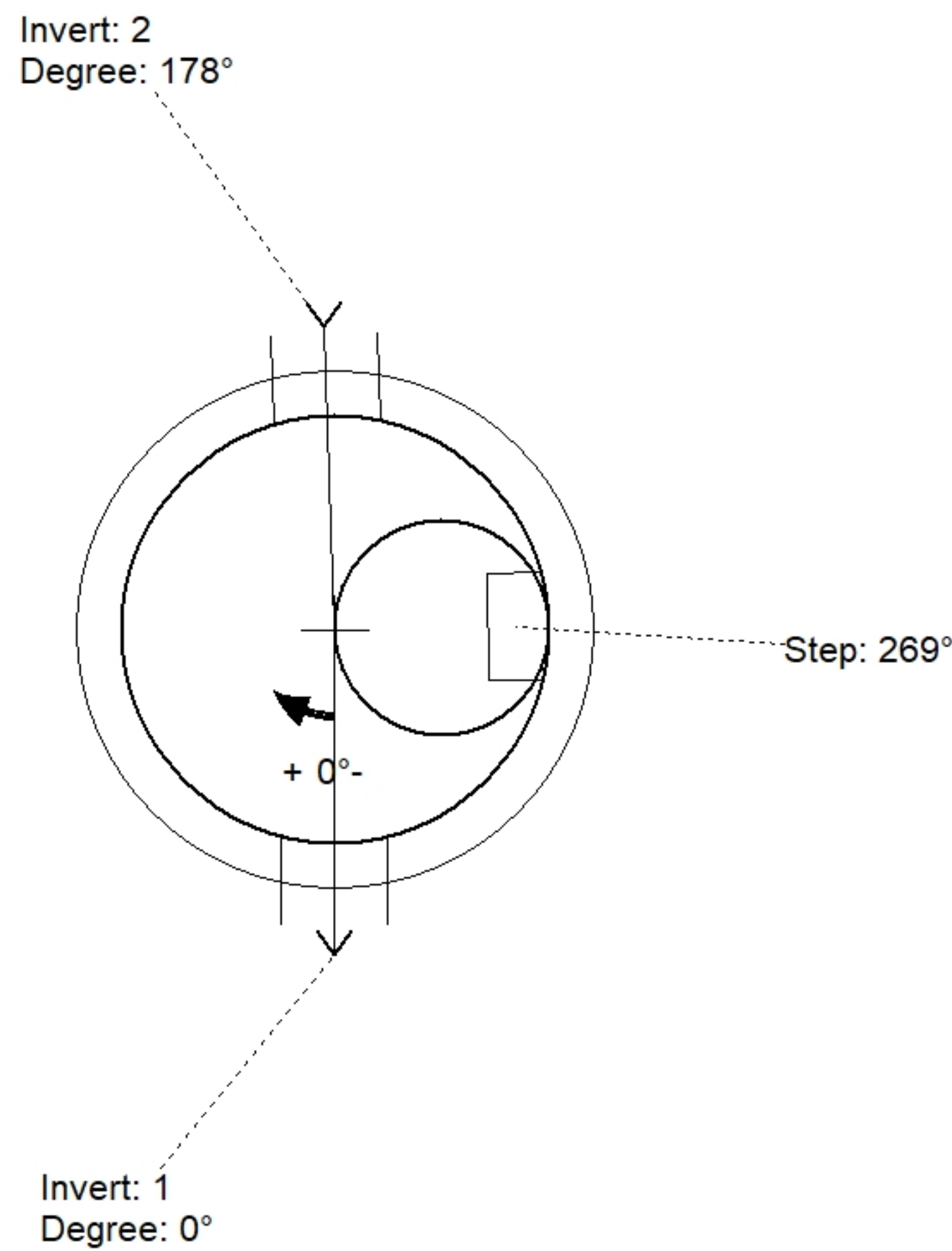

Position	Elev	Angle	Pipe	Pipe OD	Hole	Connector	Up (")	Ref
Rim	795.82'							
Reducer								
Invert 1	788.75'	0°	8" PVC SDR26	8.5"	12"	PSX 12-08 NYLO	0"	P1
Invert 2	788.95'	178°	8" PVC SDR26	8.5"	12"	PSX 12-08 NYLO	2.375"	P1
Invert 3								
Invert 4								
Invert 5								
Invert 6								
Invert 7								
Invert 8								

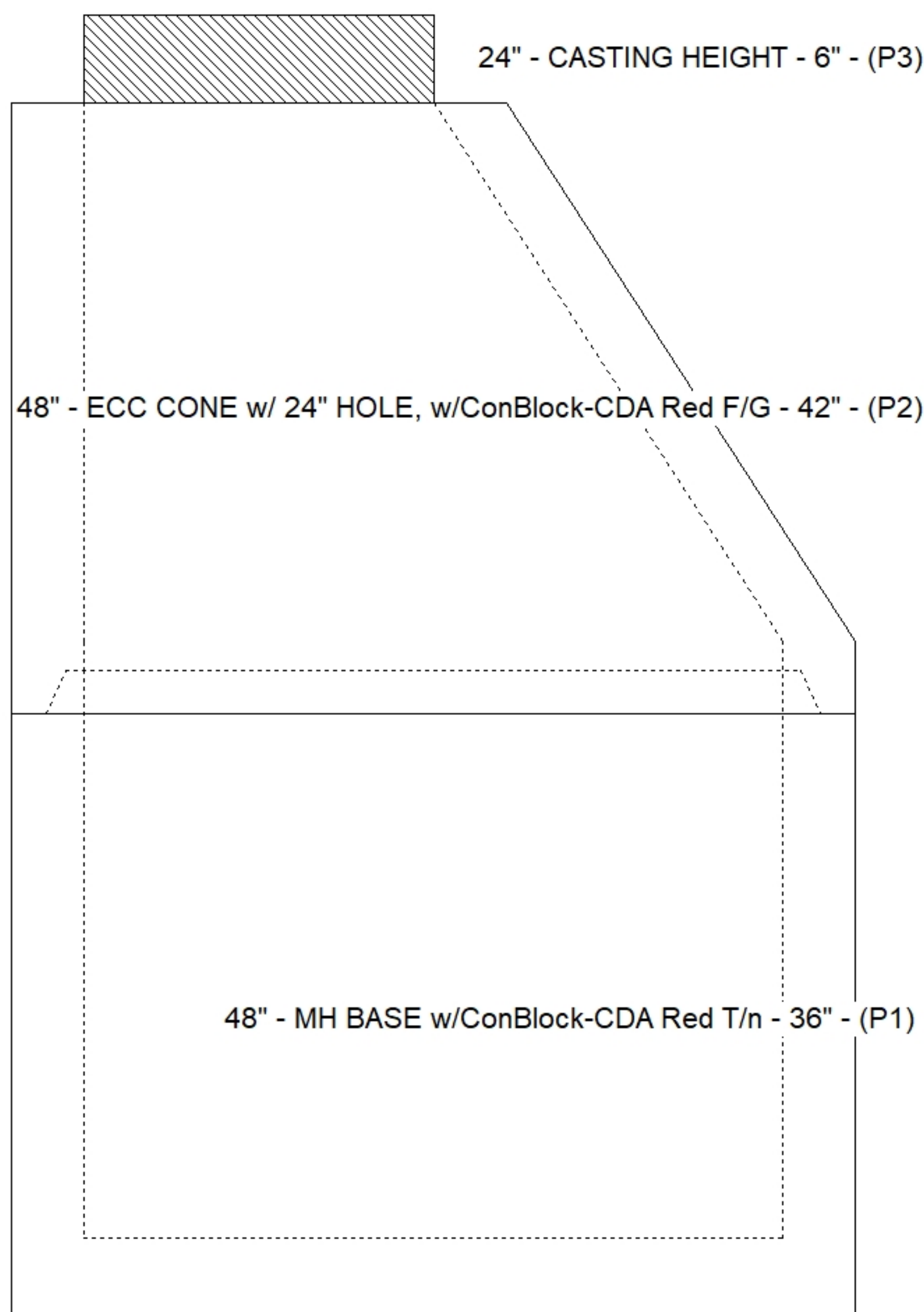

Cast (Int. Dim.) - Interior Dimensions

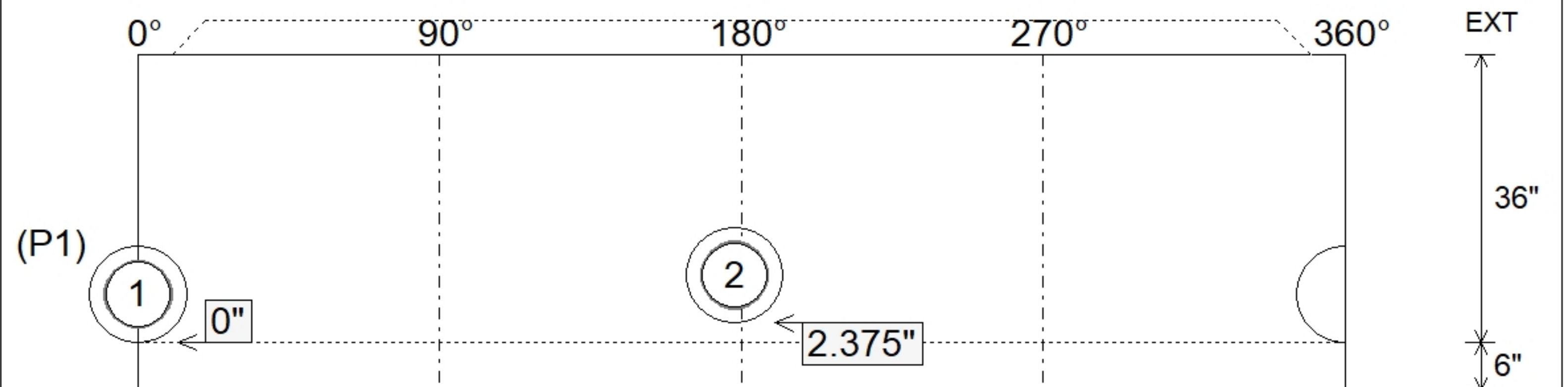

Submittal Drawing
2/3/2026 7:28:13 AM

SUBMITTAL
APPROVED BY: