

Job Name: 25-4727- Calista Subdivision (Ph.3)

Job Location: White House, TN

Contractor: Twin States Utilities, Inc.

PC: E. Bradley

TECH: J. Horsley - F

Plant: 100



Structure ID: **MH 9-4 (10)**

Spec: Sanitary

Type: SAN.MH w/ConBlock-CDA Red

Size: 48"

Rim: 798.26'

Invert: 787.9'

Rim to Invert: 10.36'

Sump: 2"

Floor (Top): 787.733'

Floor Height: 6"

Floor (Bot): 787.233'

Overall Height: 11'

Slack: 0.32"

Structure Notes:

1. PER ASTM C478 SPECIFICATIONS.
2. CONCRETE = 4,000 PSI AT 28 DAYS.
3. ADMIXTURE = CONBLOCK CDA RED
4. CASTING BY ICAST (JBS 1155 F/C SANITARY)

REINFORCING PER ASTM A615 (GRADE 60).

- CONE (As .12)
- RISER/WALLS (As .12)
- FLOOR (As .31) #5 BARS AT 12" C.C.E.W

STRUCTURE SUMMARY:

P4) 24" - CASTING HEIGHT - 6"	0 lb
P3) 48" - ECC CONE w/ 24" HOLE, w/ConBlock-CDA Red F/G - 30"	1961 lb
P2) 48" - MH RISER w/ConBlock-CDA Red T/G - 60"	4192 lb
P1) 48" - MH BASE w/ConBlock-CDA Red T/n - 30"	3330 lb
1) JOINT WRAP - 0.065"x6"x50' CONSEAL CS212	0 lb
1) JOINT WRAP PRIMER - CONSEAL CS-75 (1 gal.)	0 lb
1) ADMIXTURE CONBLOCK CDA RED	0 lb
1) 48" - MH INVERT CHANNEL OVERSIZED w/ConBlock-CDA Red - FULL HEIGHT	1440 lb
1) CASTING - JBS 1155 F/C SANITARY	250 lb
2) 48" - Conseal CS-102 1.00" (Double)	0 lb
2) PSX - 12-08 NYLO	16 lb
10) MH Step ML-10-TDS-NCR - 10"	0 lb
Structure Total:	11189 lb

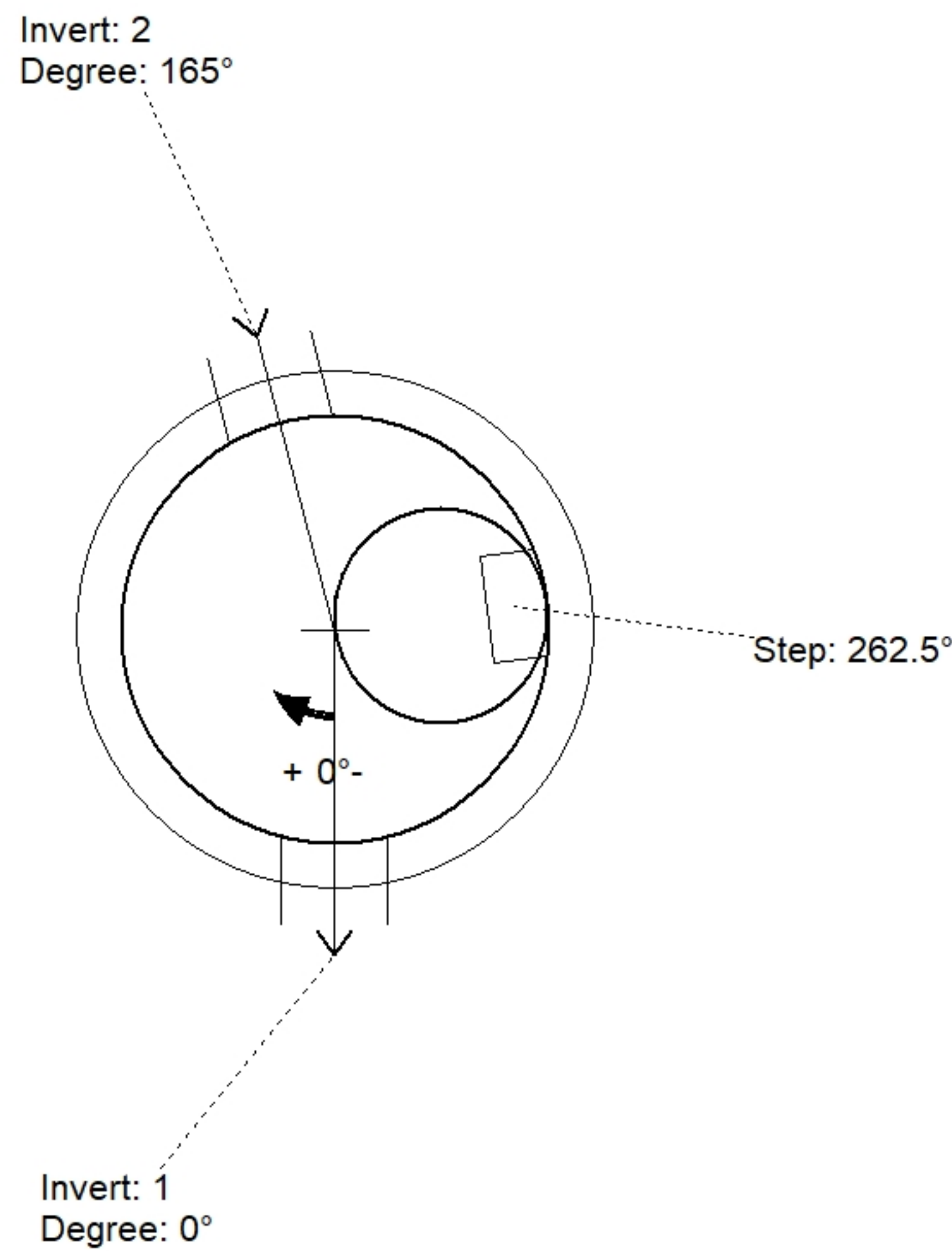

Position	Elev	Angle	Pipe	Pipe OD	Hole	Connector	Up (")	Ref
Rim	798.26'							
Reducer								
Invert 1	787.9'	0°	8" PVC SDR26	8.5"	12"	PSX 12-08 NYLO	0"	P1
Invert 2	788.1'	165°	8" PVC SDR26	8.5"	12"	PSX 12-08 NYLO	2.375"	P1
Invert 3								
Invert 4								
Invert 5								
Invert 6								
Invert 7								
Invert 8								

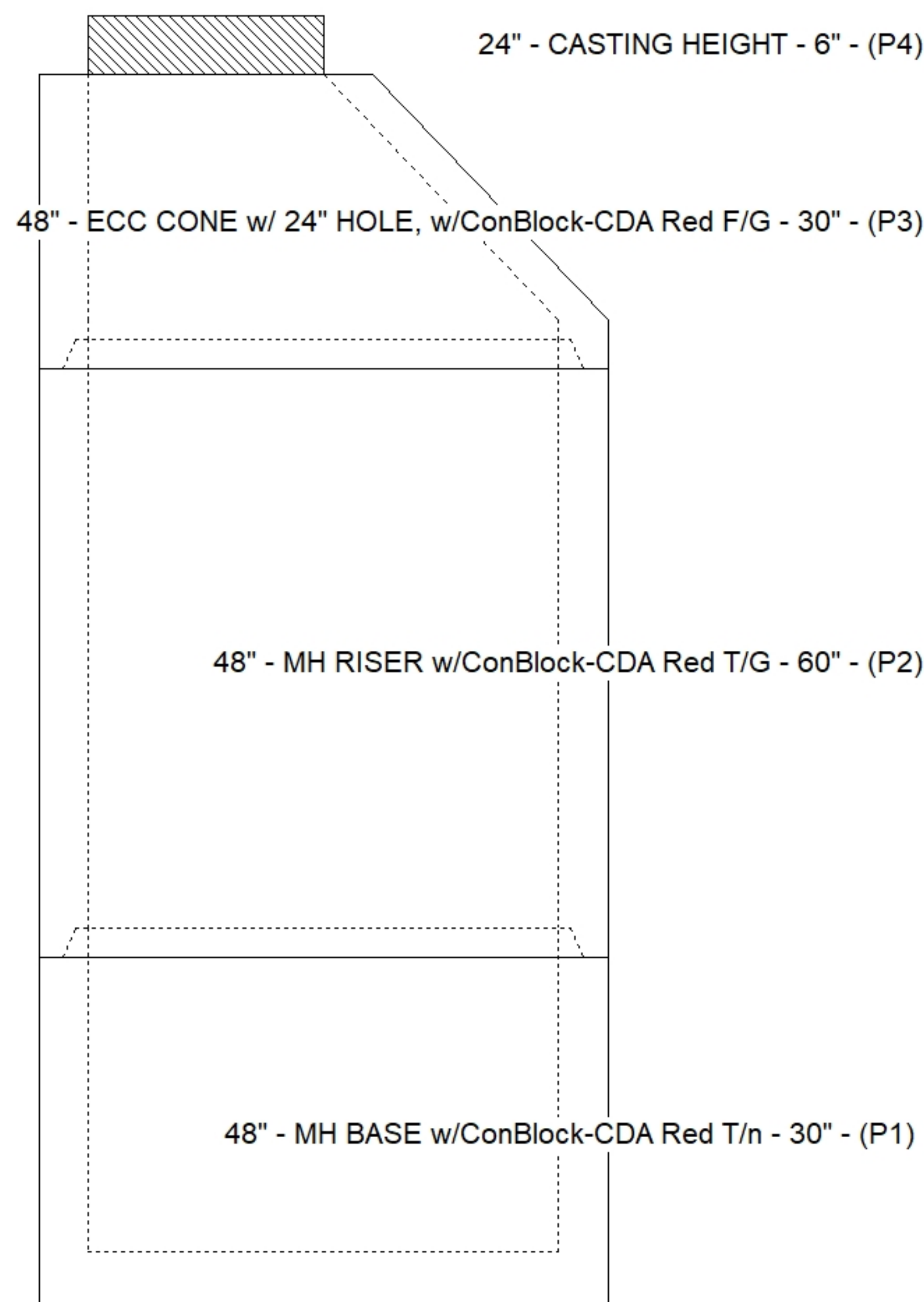

Cast (Int. Dim.) - Interior Dimensions

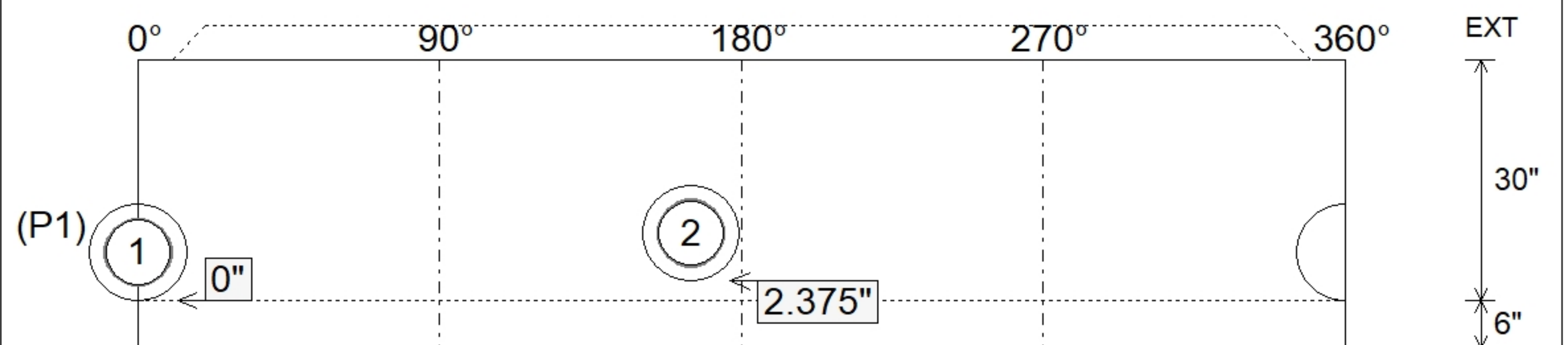

Submittal Drawing
2/3/2026 7:28:13 AM

SUBMITTAL
APPROVED BY: