

Job Name: 25-4727- Calista Subdivision (Ph.3)
 Job Location: White House, TN
 Contractor: Twin States Utilities, Inc.

Plant: 100

2/3/2026 7:28:33 AM

Tech: J. Horsley - F

PC: E. Bradley



Structure ID: MH 12-1 (6)

P1 MH048BA24CDARED

MH BASE w/ConBlock-CDA Red T/n

P5) 24" - CASTING HEIGHT - 6"	0 lb
P4) 24" - GRADE RING w/ConBlock-CDA Red F/F - 3"	202 lb
P3) 48" - ECC CONE w/ 24" HOLE, w/ConBlock-CDA Red F/G - 30"	1961 lb
P2) 48" - MH RISER w/ConBlock-CDA Red T/G - 36"	2515 lb
P1) 48" - MH BASE w/ConBlock-CDA Red T/n - 24"	2911 lb
1) JOINT WRAP - 0.065"x6"x50' CONSEAL CS212	0 lb
1) JOINT WRAP PRIMER - CONSEAL CS-75 (1 gal.)	0 lb
1) ADMIXTURE CONBLOCK CDA RED	0 lb
1) 48" - MH INVERT CHANNEL OVERSIZED w/ConBlock-CDA Red - FULL HEIGHT	1440 lb
1) CASTING - JBS 1155 F/C SANITARY	250 lb
2) 48" - Conseal CS-102 1.00" (Double)	0 lb
2) PSX - 12-08 NYLO	16 lb
8) MH Step ML-10-TDS-NCR - 10"	0 lb
Structure Total:	9296 lb

- Structure Notes:**
1. PER ASTM C478 SPECIFICATIONS.
 2. CONCRETE = 4,000 PSI AT 28 DAYS.
 3. ADMIXTURE = CONBLOCK CDA RED
 4. CASTING BY ICAST (JBS 1155 F/C SANITARY)

REINFORCING PER ASTM A615 (GRADE 60).
 - CONE (As .12)
 - RISER/WALLS (As .12)
 - FLOOR (As .31) #5 BARS AT 12" C.C.E.W

Rim: 808.78' Rim to Invert: 8.1' Slack: 0.2" Sump: 2" Step Position: 100°

Position	Elev	Angle	Ext. (cw)	Pipe	Pipe OD	Connector	Hole	Horz Size	Up ()	Offset
Invert 1	800.68'	0°	0"	8" PVC SDR26	8.5"	PSX 12-08 NYLO	12"	12.129"	0"	0"
Invert 2	800.88'	200°	101.25"	8" PVC SDR26	8.5"	PSX 12-08 NYLO	12"	12.129"	2.375"	0"
Invert 3										
Invert 4										
Invert 5										
Invert 6										
Invert 7										
Invert 8										

RIGHT-SIDE UP VIEW (int. dimensions)

UPSIDE-DOWN VIEW (int. dimenions)

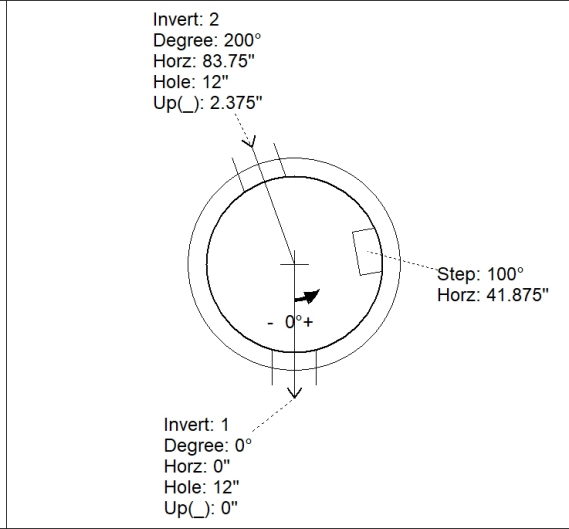
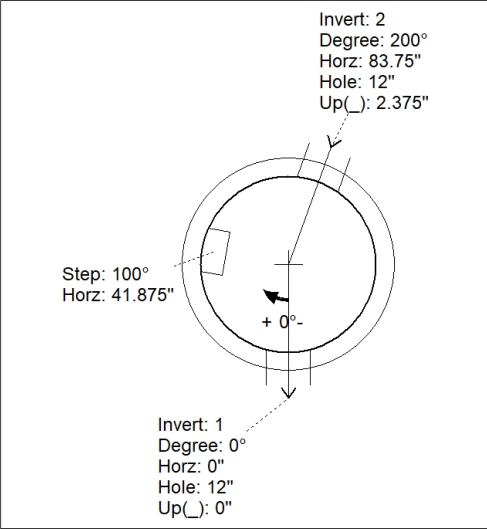
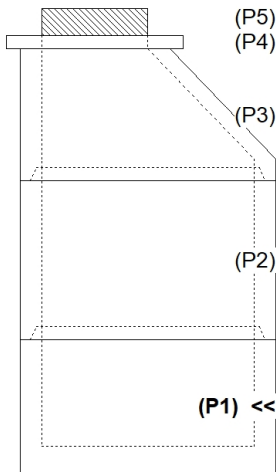

INSIDE WALL DIMENSIONS

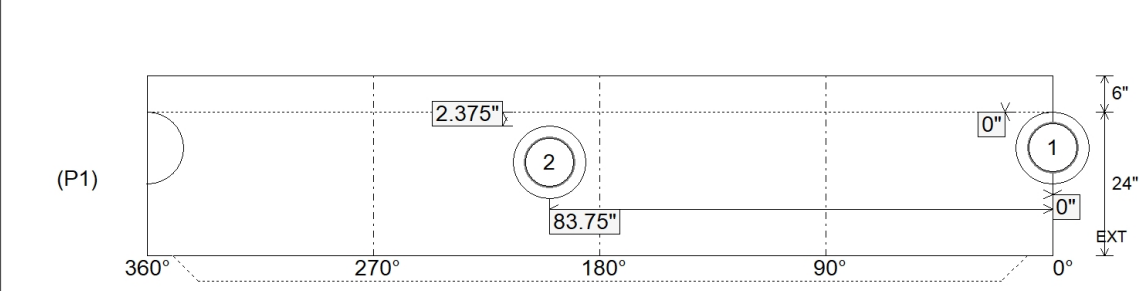

Coating (Int): Coating (Ext):	Seam Up: Tongue Seam Dn: n/a	Wall Thickness: 5" Floor Height: 6"	Height (Int): 24" Height (Ext): 30"	Weight (Net): 2911 lb Volume (Net): 0.74cu.yd
----------------------------------	---------------------------------	--	--	--

Job Name: 25-4727- Calista Subdivision (Ph.3)
 Job Location: White House, TN
 Contractor: Twin States Utilities, Inc.

Plant: 100

2/3/2026 7:28:33 AM

Tech: J. Horsley - F

PC: E. Bradley



Structure ID: MH 12-1 (6)

P1A MH048BA24CDARED

MH BASE w/ConBlock-CDA Red T/n

- P5) 24" - CASTING HEIGHT - 6"
- P4) 24" - GRADE RING w/ConBlock-CDA Red F/F - 3"
- P3) 48" - ECC CONE w/ 24" HOLE, w/ConBlock-CDA Red F/G - 30"
- P2) 48" - MH RISER w/ConBlock-CDA Red T/G - 36"
- P1) 48" - MH BASE w/ConBlock-CDA Red T/n - 24"
- 1) JOINT WRAP - 0.065"x6"x50' CONSEAL CS212
- 1) JOINT WRAP PRIMER - CONSEAL CS-75 (1 gal.)
- 1) ADMIXTURE CONBLOCK CDA RED
- 1) 48" - MH INVERT CHANNEL OVERSIZED w/ConBlock-CDA Red - FULL HEIGHT
- 1) CASTING - JBS 1155 F/C SANITARY
- 2) 48" - Conseal CS-102 1.00" (Double)
- 2) PSX - 12-08 NYLO
- 8) MH Step ML-10-TDS-NCR - 10"

0 lb
 202 lb
 1961 lb
 2515 lb
 2911 lb
 0 lb
 0 lb
 0 lb
 1440 lb
 250 lb
 0 lb
 16 lb
 0 lb

 Structure Total: 9296 lb

- Structure Notes:**
1. PER ASTM C478 SPECIFICATIONS.
 2. CONCRETE = 4,000 PSI AT 28 DAYS.
 3. ADMIXTURE = CONBLOCK CDA RED
 4. CASTING BY ICAST (JBS 1155 F/C SANITARY)

REINFORCING PER ASTM A615 (GRADE 60).
 - CONE (As .12)
 - RISER/WALLS (As .12)
 - FLOOR (As .31) #5 BARS AT 12" C.C.E.W

Rim: 808.78' Rim to Invert: 8.1' Slack: 0.2" Sump: 2" Step Position: 100°

Position	Elev	Angle	Ext. (cw)	Pipe	Pipe OD	Connector	Hole	Horz Size	Up ()	Offset
Invert 1	800.68'	0°	0"	8" PVC SDR26	8.5"	PSX 12-08 NYLO	12"	12.129"	0"	0"
Invert 2	800.88'	200°	101.25"	8" PVC SDR26	8.5"	PSX 12-08 NYLO	12"	12.129"	2.375"	0"
Invert 3										
Invert 4										
Invert 5										
Invert 6										
Invert 7										
Invert 8										

RIGHT-SIDE UP VIEW (int. dimensions)

UPSIDE-DOWN VIEW (int. dimensions)

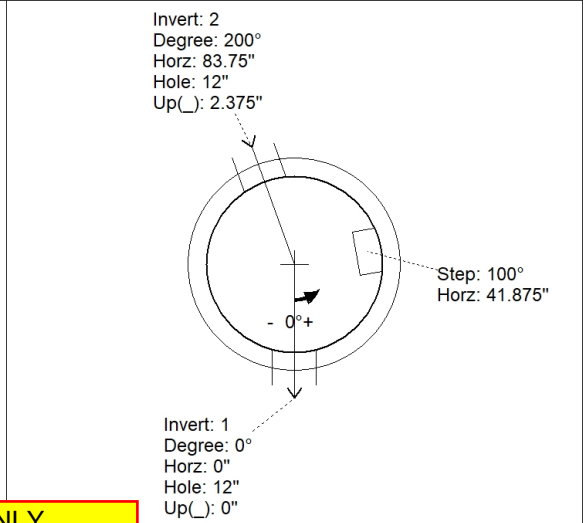
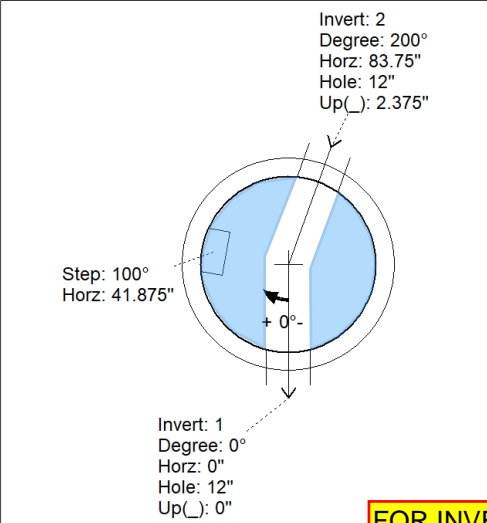
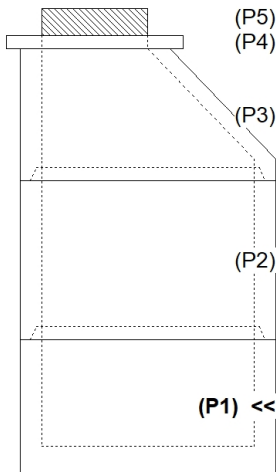

**FOR INVERT ONLY
 MAKE INVERT 2" WIDER
 THAN NORMAL**

INSIDE WALL DIMENSIONS

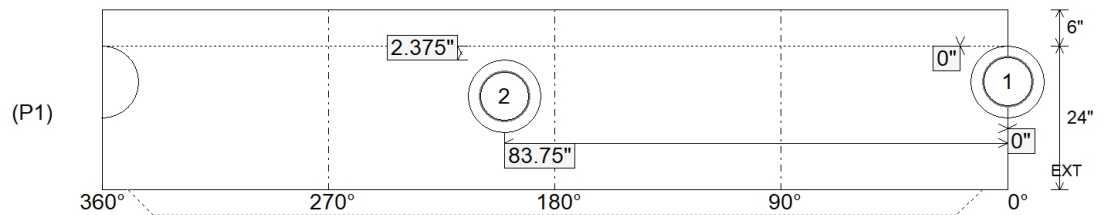

Coating (Int):
 Coating (Ext):

Seam Up: Tongue
 Seam Dn: n/a

Wall Thickness: 5"
 Floor Height: 6"

Height (Int): 24"
 Height (Ext): 30"

Weight (Net): 2911 lb
 Volume (Net): 0.74cu.yd