

Job Name: 25-4727- Calista Subdivision (Ph.3)	Plant: 100	Tech: J. Horsley - F	
Job Location: White House, TN Contractor: Twin States Utilities, Inc.	2/3/2026 7:30:33 AM	PC: E. Bradley	

**Structure ID: MH 11-4 (5)**

**P2 MH048CN24CDARED**

**ECC CONE w/ 24" HOLE, w/ConBlock-CDA Red F/G**

P4) 24" - CASTING HEIGHT - 6"	0 lb
P3) 24" - GRADE RING w/ConBlock-CDA Red F/F - 3"	202 lb
P2) 48" - ECC CONE w/ 24" HOLE, w/ConBlock-CDA Red F/G - 24"	1738 lb
P1) 48" - MH BASE w/ConBlock-CDA Red T/n - 30"	3378 lb
1) JOINT WRAP - 0.065"x6"x50' CONSEAL CS212	0 lb
1) JOINT WRAP PRIMER - CONSEAL CS-75 (1 gal.)	0 lb
1) ADMIXTURE CONBLOCK CDA RED	0 lb
1) 48" - MH INVERT CHANNEL OVERSIZED w/ConBlock-CDA Red - FULL HEIGHT	1440 lb
1) CASTING - JBS 1155 F/C SANITARY	250 lb
1) 48" - Conseal CS-102 1.00" (Double)	0 lb
1) PSX - 12-08 NYLO	8 lb
4) MH Step ML-10-TDS-NCR - 10"	0 lb
<b>Structure Total:</b>	<b>7017 lb</b>

Structure Notes:  
 1. PER ASTM C478 SPECIFICATIONS.  
 2. CONCRETE = 4,000 PSI AT 28 DAYS.  
 3. ADMIXTURE = CONBLOCK CDA RED  
 4. CASTING BY ICAST (JBS 1155 F/C SANITARY)

REINFORCING PER ASTM A615 (GRADE 60).  
 - CONE (As .12)  
 - RISER/WALLS (As .12)  
 - FLOOR (As .31) #5 BARS AT 12" C.C.E.W

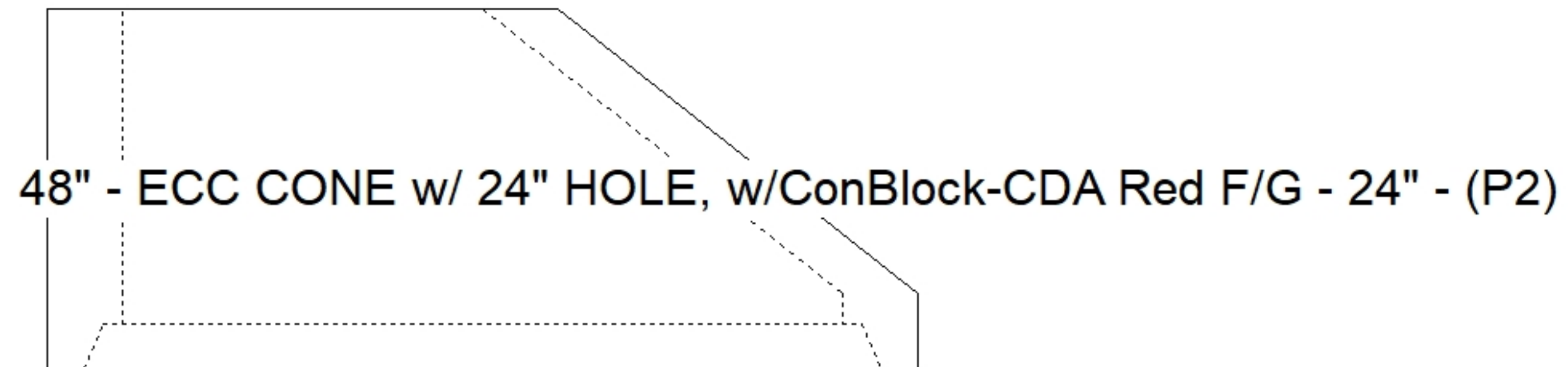
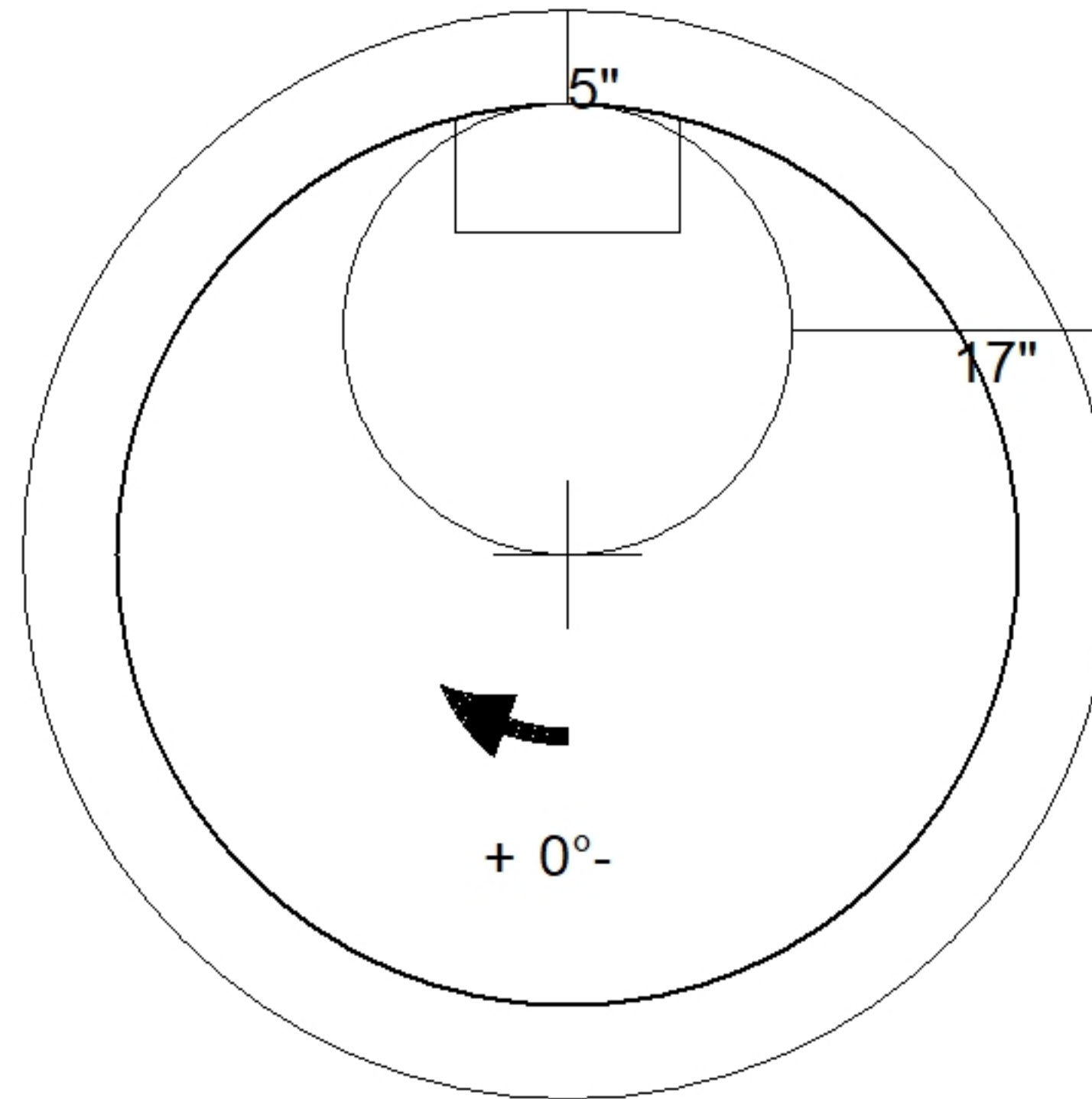

Coating (Int):	Seam Up: Flat	Wall Thickness: 5"	Height (Ext): 24"	Weight (Net): 1738 lb
Coating (Ext):	Seam Dn: Groove			Volume (Net): 0.44cu.yd