

Job Name: 25-4727- Calista Subdivision (Ph.3)
 Job Location: White House, TN
 Contractor: Twin States Utilities, Inc.

Plant: 100

2/3/2026 7:28:32 AM

Tech: J. Horsley - F

PC: E. Bradley



Structure ID: MH 11-2 (3)

P1 MH048BA30CDARED

MH BASE w/ConBlock-CDA Red T/n

- P3) 24" - CASTING HEIGHT - 6"
- P2) 48" - ECC CONE w/ 24" HOLE, w/ConBlock-CDA Red F/G - 42"
- P1) 48" - MH BASE w/ConBlock-CDA Red T/n - 30"
- 1) JOINT WRAP - 0.065"x6"x50' CONSEAL CS212
- 1) JOINT WRAP PRIMER - CONSEAL CS-75 (1 gal.)
- 1) ADMIXTURE CONBLOCK CDA RED
- 1) 48" - MH INVERT CHANNEL OVERSIZED w/ConBlock-CDA Red - FULL HEIGHT
- 1) CASTING - JBS 1155 F/C SANITARY
- 1) 48" - Conseal CS-102 1.00" (Double)
- 3) PSX - 12-08 NYLO
- 6) MH Step ML-10-TDS-NCR - 10"

0 lb
 3116 lb
 3282 lb
 0 lb
 0 lb
 0 lb
 1440 lb
 250 lb
 0 lb
 24 lb
 0 lb

 Structure Total: 8113 lb

Structure Notes:

1. PER ASTM C478 SPECIFICATIONS.
2. CONCRETE = 4,000 PSI AT 28 DAYS.
3. ADMIXTURE = CONBLOCK CDA RED
4. CASTING BY ICAST (JBS 1155 F/C SANITARY)

REINFORCING PER ASTM A615 (GRADE 60).

- CONE (As .12)
- RISER/WALLS (As .12)
- FLOOR (As .31) #5 BARS AT 12" C.C.E.W

Rim: 806.38' Rim to Invert: 6.52' Slack: 2.24" Sump: 2" Step Position: 270°

Position	Elev	Angle	Ext. (cw)	Pipe	Pipe OD	Connector	Hole	Horz Size	Up ()	Offset
Invert 1	799.86'	0°	0"	8" PVC SDR26	8.5"	PSX 12-08 NYLO	12"	12.129"	0"	0"
Invert 2	800.06'	94°	47.625"	8" PVC SDR26	8.5"	PSX 12-08 NYLO	12"	12.129"	2.375"	0"
Invert 3	800.22'	180°	91.125"	8" PVC SDR26	8.5"	PSX 12-08 NYLO	12"	12.129"	4.375"	0"
Invert 4										
Invert 5										
Invert 6										
Invert 7										
Invert 8										

RIGHT-SIDE UP VIEW (int. dimensions)

UPSIDE-DOWN VIEW (int. dimensions)

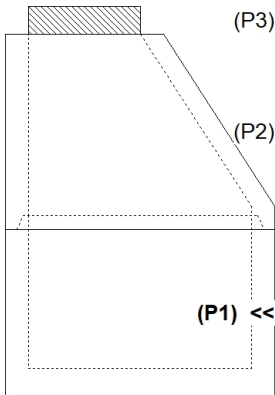
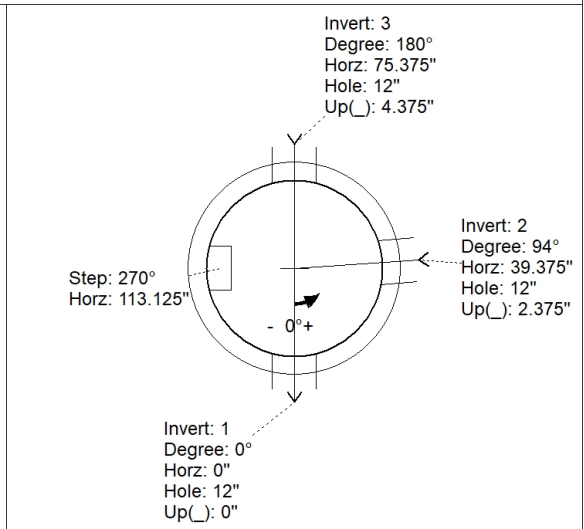
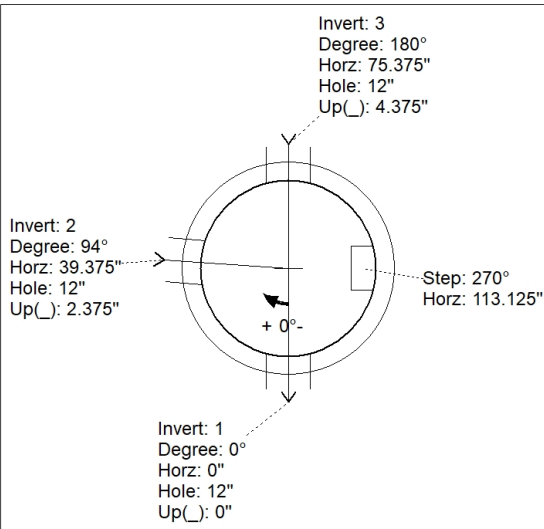

INSIDE WALL DIMENSIONS

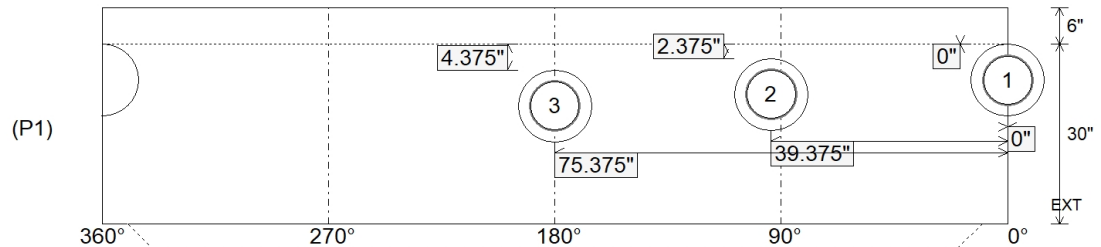

Coating (Int):
 Coating (Ext):

Seam Up: Tongue
 Seam Dn: n/a

Wall Thickness: 5"
 Floor Height: 6"

Height (Int): 30"
 Height (Ext): 36"

Weight (Net): 3282 lb
 Volume (Net): 0.84cu.yd

Job Name: 25-4727- Calista Subdivision (Ph.3)
 Job Location: White House, TN
 Contractor: Twin States Utilities, Inc.

Plant: 100

2/3/2026 7:28:32 AM

Tech: J. Horsley - F

PC: E. Bradley



Structure ID: MH 11-2 (3)

P1A MH048BA30CDARED

MH BASE w/ConBlock-CDA Red T/n

- P3) 24" - CASTING HEIGHT - 6"
- P2) 48" - ECC CONE w/ 24" HOLE, w/ConBlock-CDA Red F/G - 42"
- P1) 48" - MH BASE w/ConBlock-CDA Red T/n - 30"
- 1) JOINT WRAP - 0.065"x6"x50' CONSEAL CS212
- 1) JOINT WRAP PRIMER - CONSEAL CS-75 (1 gal.)
- 1) ADMIXTURE CONBLOCK CDA RED
- 1) 48" - MH INVERT CHANNEL OVERSIZED w/ConBlock-CDA Red - FULL HEIGHT
- 1) CASTING - JBS 1155 F/C SANITARY
- 1) 48" - Conseal CS-102 1.00" (Double)
- 3) PSX - 12-08 NYLO
- 6) MH Step ML-10-TDS-NCR - 10"

0 lb
 3116 lb
 3282 lb
 0 lb
 0 lb
 0 lb
 1440 lb
 250 lb
 0 lb
 24 lb
 0 lb
 Structure Total: 8113 lb

- Structure Notes:**
1. PER ASTM C478 SPECIFICATIONS.
 2. CONCRETE = 4,000 PSI AT 28 DAYS.
 3. ADMIXTURE = CONBLOCK CDA RED
 4. CASTING BY ICAST (JBS 1155 F/C SANITARY)

REINFORCING PER ASTM A615 (GRADE 60).
 - CONE (As .12)
 - RISER/WALLS (As .12)
 - FLOOR (As .31) #5 BARS AT 12" C.C.E.W

Rim: 806.38' Rim to Invert: 6.52' Slack: 2.24' Sump: 2' Step Position: 270°

Position	Elev	Angle	Ext. (cw)	Pipe	Pipe OD	Connector	Hole	Horz Size	Up ()	Offset
Invert 1	799.86'	0°	0"	8" PVC SDR26	8.5"	PSX 12-08 NYLO	12"	12.129"	0"	0"
Invert 2	800.06'	94°	47.625"	8" PVC SDR26	8.5"	PSX 12-08 NYLO	12"	12.129"	2.375"	0"
Invert 3	800.22'	180°	91.125"	8" PVC SDR26	8.5"	PSX 12-08 NYLO	12"	12.129"	4.375"	0"
Invert 4										
Invert 5										
Invert 6										
Invert 7										
Invert 8										

RIGHT-SIDE UP VIEW (int. dimensions)

UPSIDE-DOWN VIEW (int. dimensions)

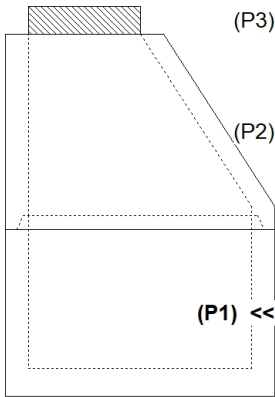
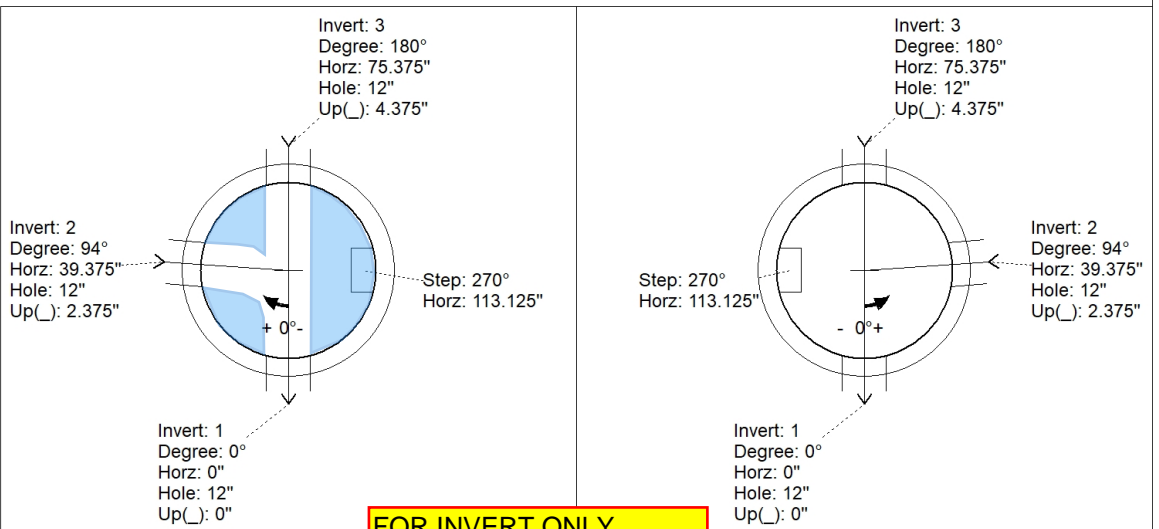

INSIDE WALL DIMENSIONS

**FOR INVERT ONLY
 MAKE INVERT 2" WIDER
 THAN NORMAL**

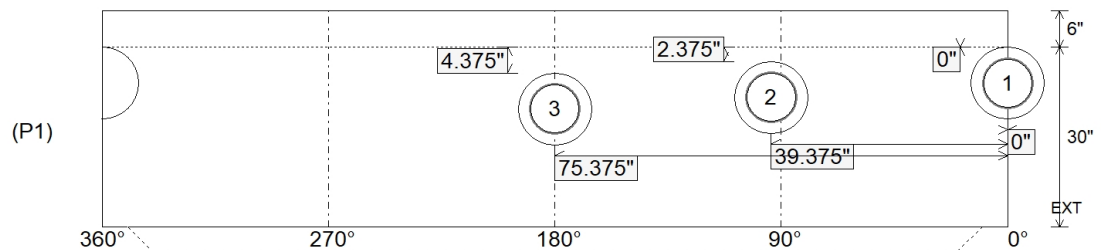

Coating (Int): Coating (Ext):	Seam Up: Tongue Seam Dn: n/a	Wall Thickness: 5" Floor Height: 6"	Height (Int): 30" Height (Ext): 36"	Weight (Net): 3282 lb Volume (Net): 0.84cu.yd
----------------------------------	---------------------------------	--	--	--