

Job Name: 25-4724 JBS Sausage Plant  
 Job Location: Perry, IA  
 Contractor: FRC Sulzer

Plant: Beaver Dam  
 3/6/2026 1:06:33 PM

Tech: S. Felletter  
 PC: T. Lewis



**Structure ID: 54724 (2)**

**P4 MH096RS96**

**MH RISER T/G**

- P6) 36" x 60" - HATCH (CAST FLUSH) - 3"
- P5) 96" - MH FLAT TOP w/36"x60" Hatch F/G - 17"
- P4) 96" - MH RISER T/G - 96"
- P3) 96" - MH RISER T/G - 90"
- P2) 96" - MH RISER T/G - 60"
- P1) 96" - MH SEPARATE BASE-T EXT. 14" (142" OD) T/n - 12"
- 1) JOINT WRAP - 12" WD x 096" MAC WRAP
- 1) HATCH (Alum.) - HALLIDAY W2S 60"x36"
- 1) This Structure Includes a Cast-in Item
- 1) SPECIAL Internal Coating
- 1) SPECIAL Pre-Assembly of Ladder
- 4) 96" - Conseal CS-231 1.00" (Double)
- 1) 36" x 60" - Conseal CS-102 1.00" (Double)
- 2) Z-Lok - C107-6
- 1) PSX - 16Y NYLO
- 1) Kor-N-Seal2 - S206-20
- 1) Kor-N-Seal2 - S206-20

100 lb  
 8297 lb  
 23535 lb  
 22182 lb  
 14947 lb  
 19580 lb  
 0 lb  
 116 lb  
 0 lb  
 0 lb  
 0 lb  
 0 lb  
 0 lb  
 2 lb  
 8 lb  
 6 lb  
 116 lb

**Structure Notes:**  
 1. PER ASTM C478 SPECIFICATIONS.  
 2. CONCRETE = 4,500 PSI AT 28 DAYS.  
 3. NO STEPS / NO INVERT CHANNEL.  
 4. HALLIDAY HATCH W2S6036 BY ICAST.  
 5. ALL COMPONENTS TO HAVE INTERIOR VERSAFLEX FE100 EPOXY COATING BY ICAST.  
 6. AL LADDER BY ICAST, INSTALLED.

12" BASE SLAB INCLUDES A 5" SOLID TONGUE

REINFORCING PER ASTM A615 (GRADE 60).  
 - TOP SLAB (As .31) #5 BARS AT 6" C.C.E.W.  
 - RISER/WALLS (As .18)  
 - FLOOR (As .37) #5 BARS AT 10" C.C.E.W.

Position	Elev	Angle	Ext. (cw)	Pipe	Structure Total Pipe OD	Connector	Hole	Horz Size	Up ( )	Offset
Invert 1	992.88'	270°	282.751"	6" PVC SCH80	6.625"	Z-Lok C107-6	10.75"	11.272"	45.48"	14"
Invert 2	992.88'	270°	254.461"	6" PVC SCH80	6.625"	Z-Lok C107-6	10.75"	11.272"	45.48"	-14"
Invert 3	990.6'	90°	89.535"	10" PVC SDR26	10.5"	PSX 16Y NYLO	16"	16.075"	17.64"	0"
Invert 4										
Invert 5	991.41'	180°	179.071"	8" PVC SDR26	8.5"	PSX 12M NYLO	12"	12.031"	28.36"	0"
Invert 6										
Invert 7										
Invert 8										

**RIGHT-SIDE UP VIEW (int. dimensions)**

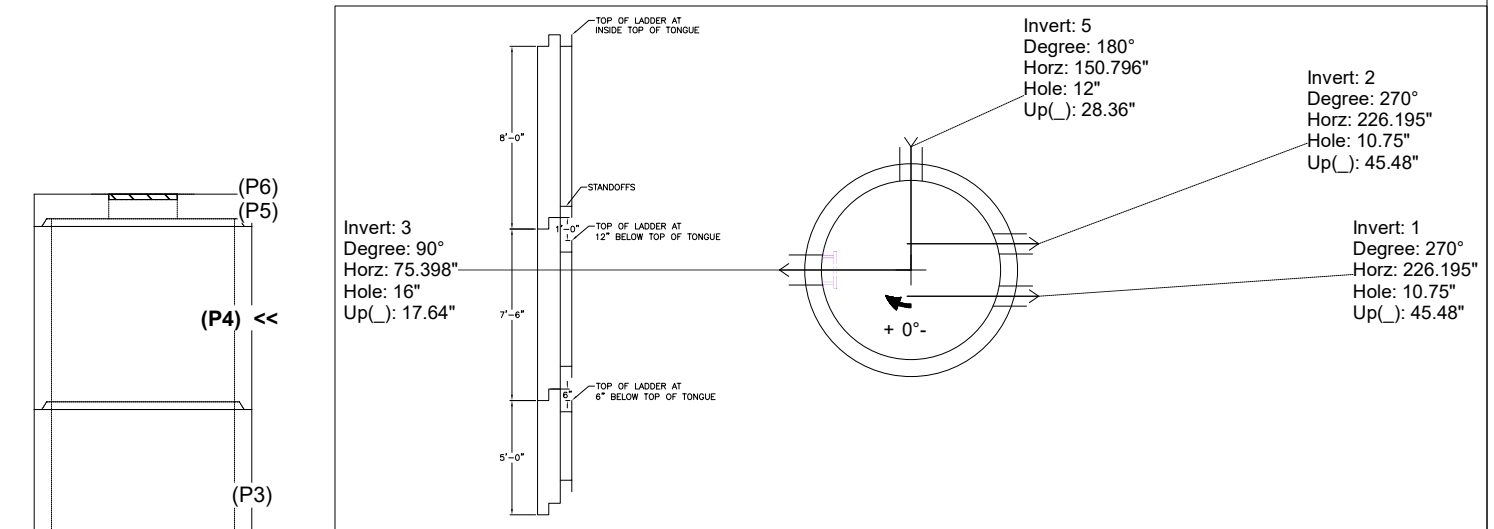

**INSIDE WALL DIMENSIONS**

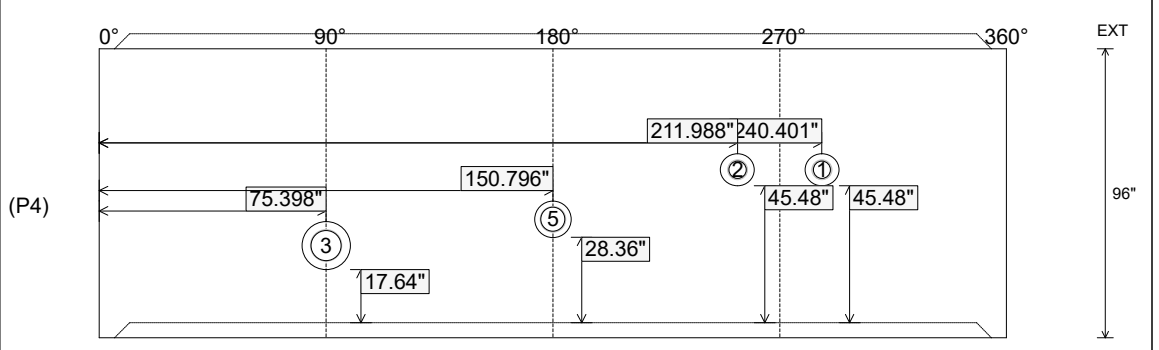

Coating (Int): Coating (Ext):	Seam Up: Tongue Seam Dn: Groove	Wall Thickness: 9" Floor Height: 0"	Height (Int): 96" Height (Ext): 96"	Weight (Net): 23535 lb Volume (Net): 6.01cu.yd
----------------------------------	------------------------------------	--	--	---