

Job Name: 25-4690 - Elk Horn Estates Unit 1
 Job Location: Winchester, KY
 Contractor: C&R Asphalt, LLC

Plant: 100

1/26/2026 11:09:28 AM

Tech: J. Horsley - F

PC: T. Lewis



Structure ID: MH 12

P2 MH048CN36

ECC CONE w/ 24" HOLE F/G

- P3) 24" - CASTING HEIGHT - 7"
- P2) 48" - ECC CONE w/ 24" HOLE F/G - 36"
- P1) 48" - MH BASE T/n - 24"

- 1) JOINT WRAP - 0.065"x6"x50' CONSEAL CS212
- 1) JOINT WRAP PRIMER - CONSEAL CS-75 (1 gal.)
- 1) 48" - MH INVERT CHANNEL - FULL HEIGHT
- 1) CASTING - HOE MC-315 F/C Sanitary
- 1) 48" - Conseal CS-102 1.00" (Double)
- 1) Quik-Lok - QL-08-C
- 1) PSX - 12-08 NYLO
- 2) PSX - 12-06 NYLO
- 4) MH Step ML-10-TDS-NCR - 10"

- 0 lb
- 3000 lb
- 2825 lb
- 0 lb
- 0 lb
- 1440 lb
- 258 lb
- 0 lb
- 1 lb
- 8 lb
- 16 lb
- 0 lb

Structure Total: 7548 lb

Structure Notes:

1. PER ASTM C-478 SPECIFICATIONS
2. CONCRETE: 4,000 PSI AT 28 DAYS
3. REINFORCEMENT: PER ASTM A615
4. STEPS REQUIRED
5. HOE MC-315 FRAME & COVER "SANITARY" SUPPLIED BY ICAST

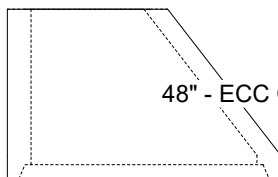
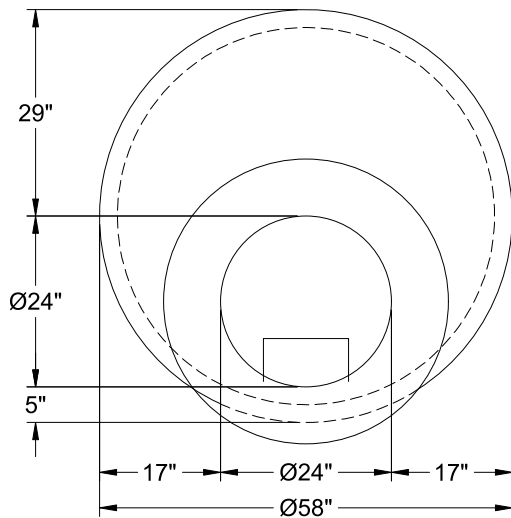

48" - ECC CONE w/ 24" HOLE F/G - 36" - (P2)

Coating (Int):
 Coating (Ext):

Seam Up: Flat
 Seam Dn: Groove

Wall Thickness: 5"

Height (Ext): 36"

Weight (Net): 3000 lb
 Volume (Net): 0.5cu.yd