

**Structure ID: MH 12**

**P1 MH048BA24**

**MH BASE T/n**

P3) 24" - CASTING HEIGHT - 7" P2) 48" - ECC CONE w/ 24" HOLE F/G - 36" P1) 48" - MH BASE T/n - 24" 1) JOINT WRAP - 0.065"x6"x50' CONSEAL CS212 1) JOINT WRAP PRIMER - CONSEAL CS-75 (1 gal.) 1) 48" - MH INVERT CHANNEL - FULL HEIGHT 1) CASTING - HOE MC-315 F/C Sanitary 1) 48" - Conseal CS-102 1.00" (Double) 1) Quik-Lok - QL-08-C 1) PSX - 12-08 NYLO 2) PSX - 12-06 NYLO 4) MH Step ML-10-TDS-NCR - 10"	0 lb 3000 lb 2825 lb 0 lb 0 lb 1440 lb 258 lb 0 lb 1 lb 8 lb 16 lb 0 lb ----- Structure Total: 7548 lb
---	---

**Structure Notes:**  
 1. PER ASTM C-478 SPECIFICATIONS  
 2. CONCRETE: 4,000 PSI AT 28 DAYS  
 3. REINFORCEMENT: PER ASTM A615  
 4. INVERT CHANNEL REQUIRED  
 5. STEPS AT 0 DEGREES  
 6. HOE MC-315 FRAME & COVER "SANITARY" SUPPLIED BY ICAST

Rim: 1023.5'    Rim to Invert: 5.55'    Slack: 1.6"    Sump: 2"    Step Position: 0°

Position	Elev	Angle	Ext. (cw)	Pipe	Pipe OD	Connector	Hole	Horz Size	Up ( )	Offset
Invert 1	1017.95'	0°	0"	8" PVC SDR26	8.5"	Quik-Lok QL-08-C	10.75"	10.842"	0.625"	0"
Invert 2	1018.05'	115°	58.207"	8" PVC SDR26	8.5"	PSX 12-08 NYLO	12"	12.129"	1.2"	0"
Invert 3	1018.15'	180°	91.106"	6" PVC SDR26	6.25"	PSX 12-06 NYLO	12"	12.129"	1.4"	0"
Invert 4	1018.15'	270°	136.659"	6" PVC SDR26	6.25"	PSX 12-06 NYLO	12"	12.129"	1.4"	0"
Invert 5										
Invert 6										
Invert 7										
Invert 8										

RIGHT-SIDE UP VIEW (int. dimensions)

UPSIDE-DOWN VIEW (int. dimensions)

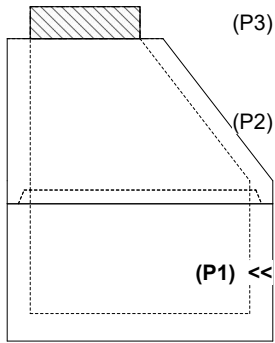
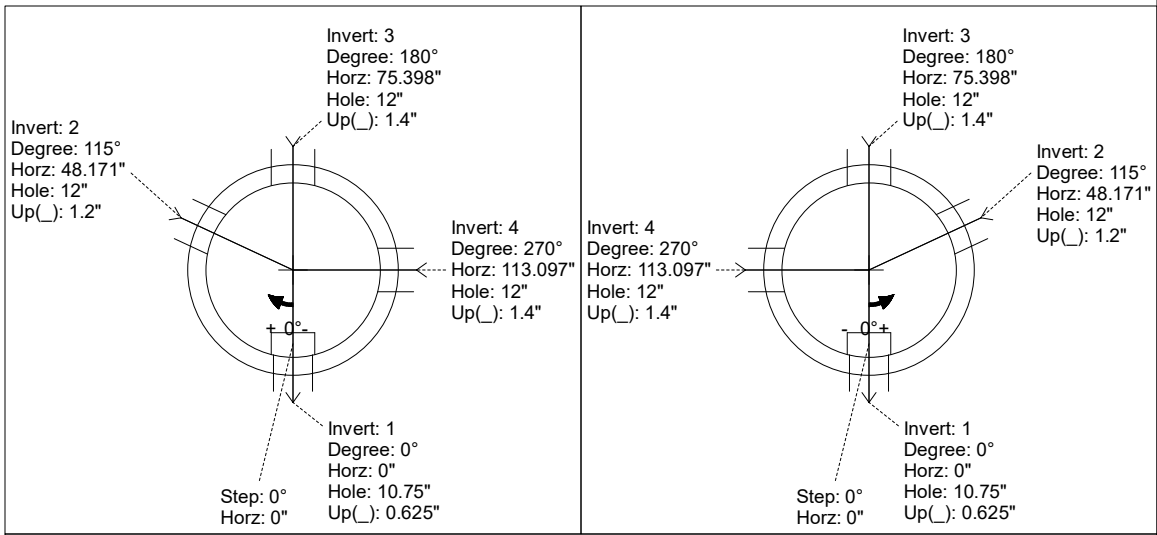

INSIDE WALL DIMENSIONS

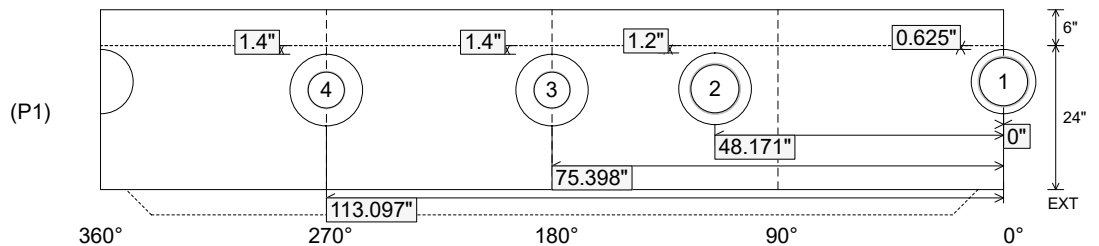

Coating (Int): Coating (Ext):	Seam Up: Tongue Seam Dn: n/a	Wall Thickness: 5" Floor Height: 6"	Height (Int): 24" Height (Ext): 30"	Weight (Net): 2825 lb Volume (Net): 0.72cu.yd
----------------------------------	---------------------------------	--	--	--

Job Name: 25-4690 - Elk Horn Estates Unit 1  
 Job Location: Winchester, KY  
 Contractor: C&R Asphalt, LLC

Plant: 100

Tech: J. Horsley - F

1/26/2026 11:08:43 AM

PC: T. Lewis



**Structure ID: MH 12**

**P1 MH048BA24**

**MH BASE T/n**

P3) 24" - CASTING HEIGHT - 7"	0 lb
P2) 48" - ECC CONE w/ 24" HOLE F/G - 36"	3000 lb
P1) 48" - MH BASE T/n - 24"	2825 lb
1) JOINT WRAP - 0.065"x6"x50' CONSEAL CS212	0 lb
1) JOINT WRAP PRIMER - CONSEAL CS-75 (1 gal.)	0 lb
1) 48" - MH INVERT CHANNEL - FULL HEIGHT	1440 lb
1) CASTING - HOE MC-315 F/C Sanitary	258 lb
1) 48" - Conseal CS-102 1.00" (Double)	0 lb
1) Quik-Lok - QL-08-C	1 lb
1) PSX - 12-08 NYLO	8 lb
2) PSX - 12-06 NYLO	16 lb
4) MH Step ML-10-TDS-NCR - 10"	0 lb
<b>Structure Total:</b>	<b>7548 lb</b>

**Structure Notes:**  
 1. PER ASTM C-478 SPECIFICATIONS  
 2. CONCRETE: 4,000 PSI AT 28 DAYS  
 3. REINFORCEMENT: PER ASTM A615  
 4. INVERT CHANNEL REQUIRED  
 5. STEPS AT 0 DEGREES  
 6. HOE MC-315 FRAME & COVER "SANITARY" SUPPLIED BY ICAST

Rim: 1023.5' Rim to Invert: 5.55' Slack: 1.6" Sump: 2" Step Position: 0°

Position	Elev	Angle	Ext. (cw)	Pipe	Pipe OD	Connector	Hole	Horz Size	Up ( )	Offset
Invert 1	1017.95'	0°	0"	8" PVC SDR26	8.5"	Quik-Lok QL-08-C	10.75"	10.842"	0.625"	0"
Invert 2	1018.05'	115°	58.207"	8" PVC SDR26	8.5"	PSX 12-08 NYLO	12"	12.129"	1.2"	0"
Invert 3	1018.15'	180°	91.106"	6" PVC SDR26	6.25"	PSX 12-06 NYLO	12"	12.129"	1.4"	0"
Invert 4	1018.15'	270°	136.659"	6" PVC SDR26	6.25"	PSX 12-06 NYLO	12"	12.129"	1.4"	0"
Invert 5										
Invert 6										
Invert 7										
Invert 8										

RIGHT-SIDE UP VIEW (int. dimensions)

UPSIDE-DOWN VIEW (int. dimensions)

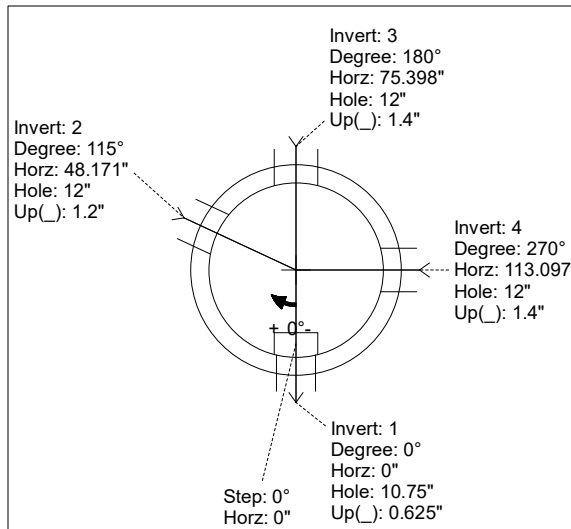

**INVERT CHANNEL DRAWING**

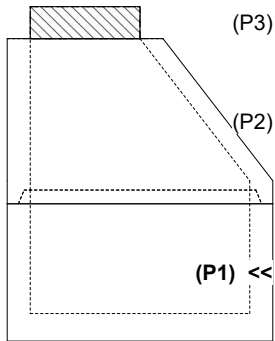

INSIDE WALL DIMENSIONS

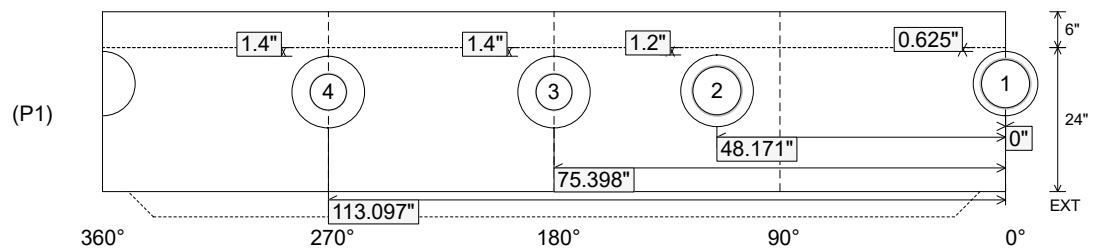

Coating (Int):  
 Coating (Ext):

Seam Up: Tongue  
 Seam Dn: n/a

Wall Thickness: 5"  
 Floor Height: 6"

Height (Int): 24"  
 Height (Ext): 30"

Weight (Net): 2825 lb  
 Volume (Net): 0.72cu.yd