

Job Name: 25-4690 - Elk Horn Estates Unit 1
 Job Location: Winchester, KY
 Contractor: C&R Asphalt, LLC

Plant: 100

1/26/2026 11:09:27 AM

Tech: J. Horsley - F

PC: T. Lewis



Structure ID: MH 11

P2 MH048CN30

ECC CONE w/ 24" HOLE F/G

- P3) 24" - CASTING HEIGHT - 7"
- P2) 48" - ECC CONE w/ 24" HOLE F/G - 30"
- P1) 48" - MH BASE T/n - 24"
- 1) JOINT WRAP - 0.065"x6"x50' CONSEAL CS212
- 1) JOINT WRAP PRIMER - CONSEAL CS-75 (1 gal.)
- 1) 48" - MH INVERT CHANNEL - FULL HEIGHT
- 1) CASTING - HOE MC-315 F/C Sanitary
- 1) 48" - Conseal CS-102 1.00" (Double)
- 2) Quik-Lok - QL-08-C
- 4) MH Step ML-10-TDS-NCR - 10"

- 0 lb
- 2050 lb
- 2930 lb
- 0 lb
- 0 lb
- 1440 lb
- 258 lb
- 0 lb
- 2 lb
- 0 lb
-

Structure Total: 6680 lb

- Structure Notes:**
1. PER ASTM C-478 SPECIFICATIONS
 2. CONCRETE: 4,000 PSI AT 28 DAYS
 3. REINFORCEMENT: PER ASTM A615
 4. STEPS REQUIRED
 5. HOE MC-315 FRAME & COVER "SANITARY" SUPPLIED BY ICAST

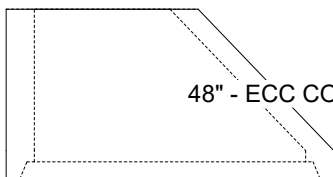
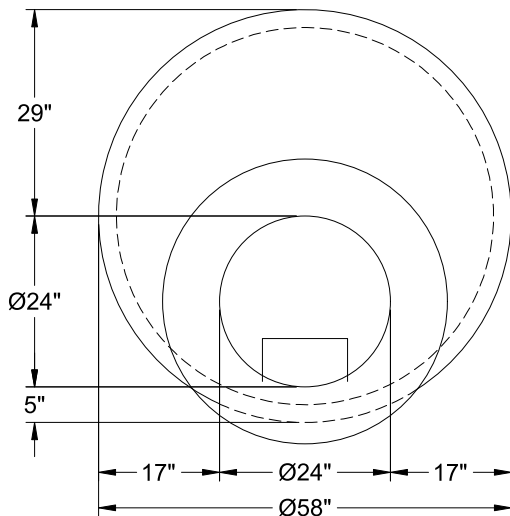

48" - ECC CONE w/ 24" HOLE F/G - 30" - (P2)

Coating (Int):
 Coating (Ext):

Seam Up: Flat
 Seam Dn: Groove

Wall Thickness: 5"

Height (Ext): 30"

Weight (Net): 2050 lb
 Volume (Net): 0.41cu.yd