

Job Name: 25-4690 - Elk Horn Estates Unit 1
 Job Location: Winchester, KY
 Contractor: C&R Asphalt, LLC

Plant: 100

1/26/2026 11:09:27 AM

Tech: J. Horsley - F

PC: T. Lewis



Structure ID: JB2

P2 MH048LD12ECC

MH FLAT TOP w/ 24" ECC Hole F/G

- P4) 24" - CASTING HEIGHT - 7"
- P3) 24" - GRADE RING F/F - 4"
- P2) 48" - MH FLAT TOP w/ 24" ECC Hole F/G - 12"
- P1) 48" - MH BASE T/n - 24"
- 1) CASTING - HOE MCB-315-R F/G
- 1) 48" - Conseal CS-102 1.00"
- 2) Hole - 20"
- 2) MH Step ML-10-TDS-NCR - 10"

	0 lb
	270 lb
	1561 lb
	2736 lb
	258 lb
	0 lb
	0 lb
	0 lb
Structure Total:	4825 lb

- Structure Notes:
1. PER ASTM C-478 SPECIFICATIONS
 2. CONCRETE: 4,000 PSI AT 28 DAYS
 3. REINFORCEMENT: #4 BAR @ 10" C.C. E.W. (GRADE 60) - 2" MIN. REBAR CLEARANCE (TYP)
 4. HOE MCB-315-R FRAME & RADIAL GRATE SUPPLIED BY ICAST
 5. LIFTERS: 3 EA. WRA016 CONAC WIRE ROPE ANCHORS FOR PLANT & FIELD HANDLING
 6. TOP SURFACE TO RECEIVE LIGHT BRUSH FINISH

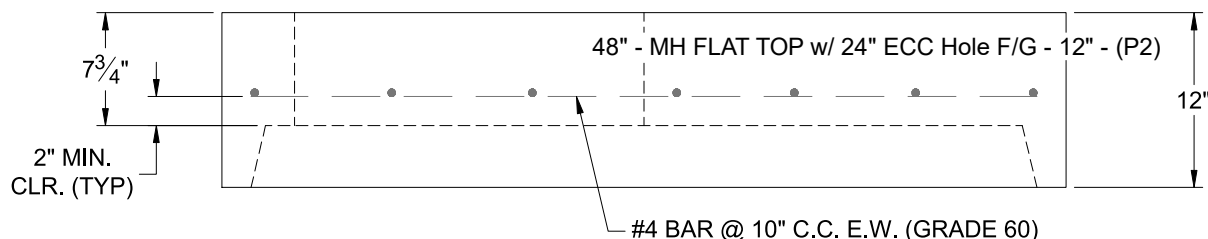
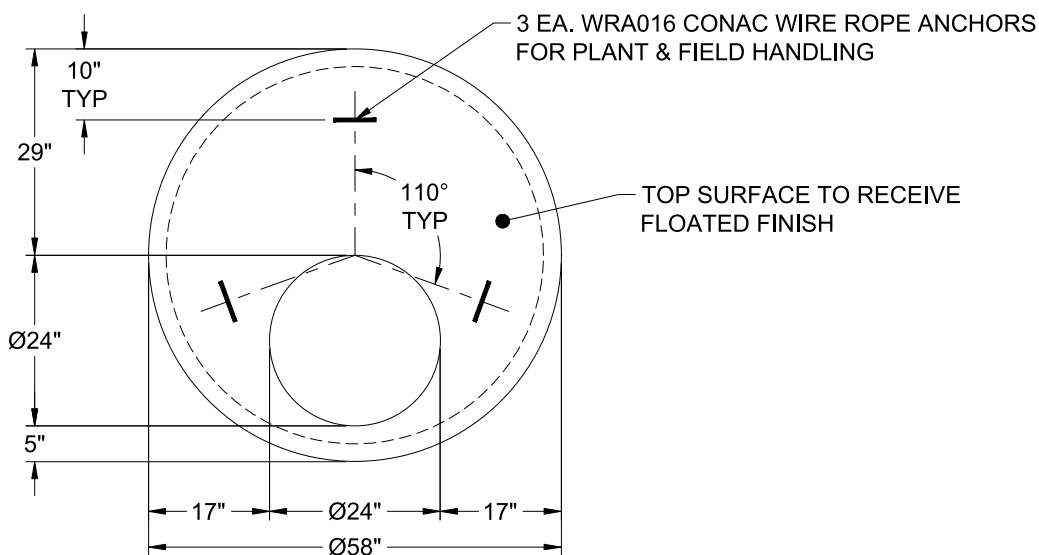

Coating (Int):
 Coating (Ext):

Seam Up: Flat
 Seam Dn: Groove

Wall Thickness: 5"

Height (Ext): 12"

Weight (Net): 1561 lb
 Volume (Net): 0.42cu.yd