

Job Name: 25-4690 - Elk Horn Estates Unit 1
 Job Location: Winchester, KY
 Contractor: C&R Asphalt, LLC

Plant: 100
 1/26/2026 11:09:26 AM

Tech: J. Horsley - F
 PC: T. Lewis



Structure ID: JB1

P2 MH048CN36

ECC CONE w/ 24" HOLE F/G

- P4) 24" - CASTING HEIGHT - 7"
- P3) 24" - GRADE RING F/F - 4"
- P2) 48" - ECC CONE w/ 24" HOLE F/G - 36"
- P1) 48" - MH BASE T/n - 48"
- 1) CASTING - HOE MCB-315-R F/G
- 1) 48" - Conseal CS-102 1.00"
- 2) Hole - 20
- 7) MH Step ML-10-TDS-NCR - 10"

0 lb
 270 lb
 3000 lb
 4413 lb
 258 lb
 0 lb
 0 lb
 0 lb

 7941 lb

Structure Total:

- Structure Notes:
1. PER ASTM C-478 SPECIFICATIONS
 2. CONCRETE: 4,000 PSI AT 28 DAYS
 3. REINFORCEMENT: PER ASTM A615
 4. STEPS REQUIRED
 5. HOE MCB-315-R FRAME & RADIAL GRATE SUPPLIED BY ICAST

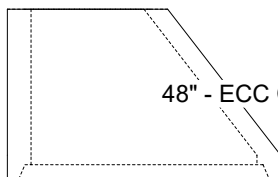
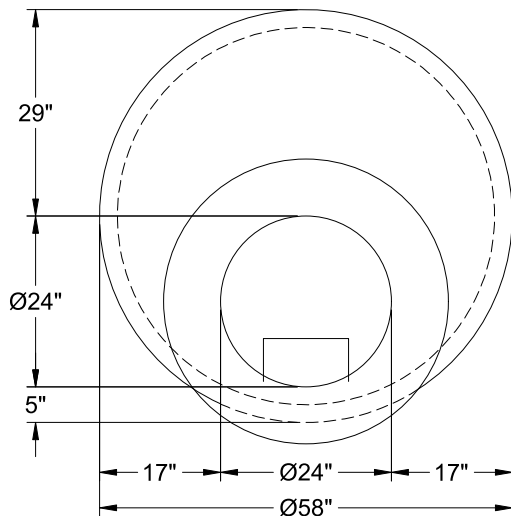

48" - ECC CONE w/ 24" HOLE F/G - 36" - (P2)

Coating (Int):
 Coating (Ext):

Seam Up: Flat
 Seam Dn: Groove

Wall Thickness: 5"

Height (Ext): 36"

Weight (Net): 3000 lb
 Volume (Net): 0.5cu.yd