

Job Name: 25-4689 Water Tank Site Improvements
 Job Location: Crossville, TN
 Contractor: John T Hall Construction

Plant: 100

3/24/2026 2:45:02 PM

Tech: Jared- A

PC: Erica Bradley



Structure ID: 54689 (2)

P2 BX120180-08RSVF

BOX RISER 8inW, Variable Ht

- P4) 60" x 72" - HATCH (CAST FLUSH) - 3"
- P3) 120" x 180" - BX FLAT LID 8"W w/60"x72" HATCH - 8"
- P2) 120" x 180" - BOX RISER 8inW, Variable Ht - 61"
- P1) 120" x 180" - BX Separate Base Slab - 14"
- 1) SECONDARY POUR - Walls
- 1) HATCH (Alum.) - HALLIDAY S2S 72"x60"
- 2) 120" x 180" - Conseal CS-231 1.00" (Double)

100 lb
 14994 lb
 25456 lb
 41351 lb
 0 lb
 225 lb
 0 lb

 Structure Total: 82126 lb

Structure Notes:

1. MANUFACTURED PER ASTM C-913 (LATEST REVISION)
2. CONCRETE: 5,000 PSI AT 28 DAYS
3. REINFORCEMENT: PER ASTM A615 (GRADE 60)
 TOP SLAB: #6 BAR @ 9" C-C E.W. DBL MAT
 WALLS: #5 BAR @ 8" C-C E.W.
 BASE SLAB: #5 BAR @ 12" C-C E.W. DBL MAT
4. HATCH: HALLIDAY S2S 60" X 72" PROVIDED BY ICAST
5. LADDER SUPPLIED BY ICAST.

Rim: 5.67' Rim to Invert: 0' Slack: 0.04" Sump: 68.04" Step Position:

GENERAL NOTES:

1. MANUFACTURED PER ASTM C-913 (LATEST REVISION)
2. CONCRETE: 5,000 PSI AT 28 DAYS
3. REINFORCEMENT – 2" MIN. REBAR CLEARANCE (TYP):
 – WALL SECTION: #5 BAR @ 8" C.C. E.W. (GRADE 60)
4. WEIGHTS: 61" RISER SECTION – 25,456 LBS
5. FLOOR MOUNT ALUMINUM LADDER REQ'D. (SUPPLIED BY ICAST).
6. JOINT TO BE SEALED WITH CS-231 1" BUTYL DOUBLE
7. (FLOOR SLOPE TO DRAIN BY OTHERS)

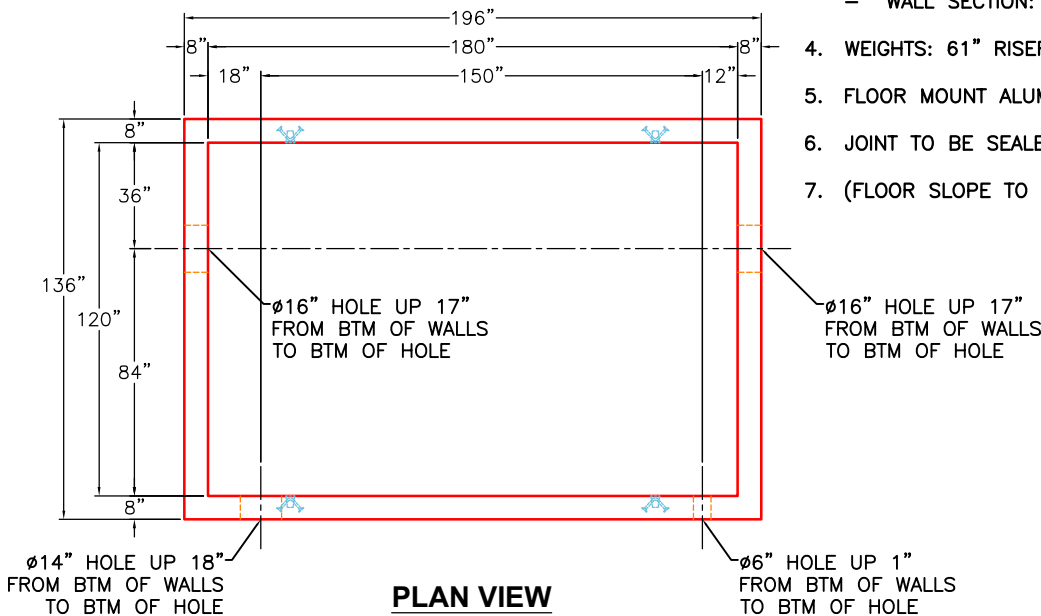

PLAN VIEW

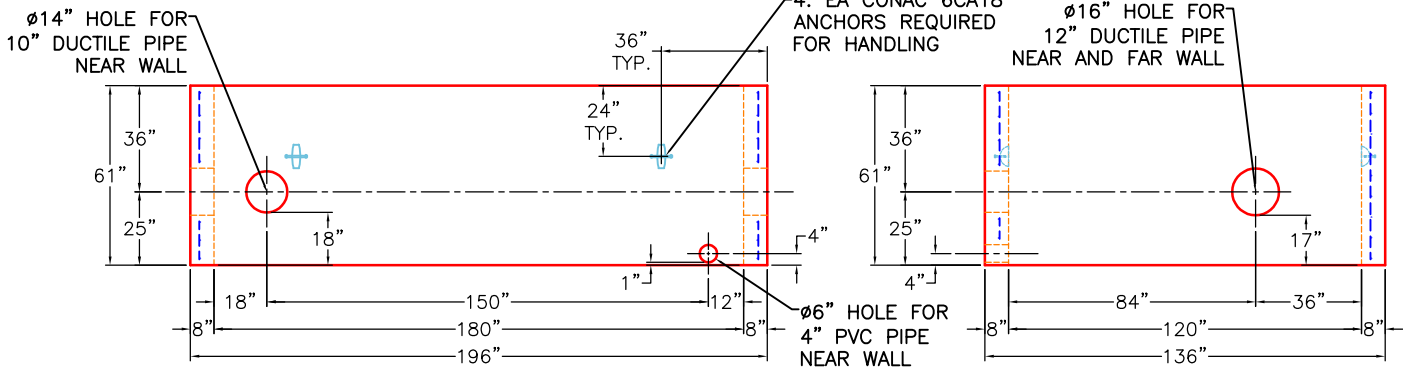

FRONT VIEW

SIDE VIEW

Coating (Int):
 Coating (Ext):

Seam Up: Flat
 Seam Dn: Flat

Wall Thickness: 8"
 Floor Height: 0"

Height (Int): 60"
 Height (Ext): 60"

Weight (Net): 25456 lb
 Volume (Net): 6.5cu.yd