

Job Name: 25-4686 Fivestar 6585  
 Job Location: Monticello, KY  
 Contractor: Weddle Enterprises, Inc

Plant: 100  
 1/24/2026 3:32:06 PM

Tech: J. Horsley - A  
 PC: Celina Goff



**Structure ID: 4 (5)**

**P1 MH048BA42**

**MH BASE T/n**

- P3) 24" x 24" - CASTING HEIGHT - 4"
- P2) 48" - MH FLAT TOP w/24"x24" Hole F/G - 12"
- P1) 48" - MH BASE T/n - 42"
- 1) 48" - Conseal CS-102 1.00"
- 1) 24" x 24" - Conseal CS-102 1.00"
- 2) Hole - 30
- 1) Hole - 24
- 3) MH Step ML-10-TDS-NCR - 10"

0 lb  
 1500 lb  
 3435 lb  
 0 lb  
 0 lb  
 0 lb  
 0 lb  
 0 lb  
 0 lb  
 Structure Total: 4935 lb

- Structure Notes:**
1. PER ASTM C-478 SPECIFICATIONS
  2. CONCRETE: 4,000 PSI AT 28 DAYS
  3. REINFORCEMENT: PER ASTM A615
  4. NO STORM INVERT
  5. STEPS AT 90 DEGREES
  6. HOE 280T FRAME & GRATE SUPPLIED BY OTHERS
  7. INVERT 2 OFFSET 1.5" FROM CENTER

Rim: 952.45' Rim to Invert: 4.68' Slack: 0.06" Sump: 1.9" Step Position: 90

Position	Elev	Angle	Ext. (cw)	Pipe	Pipe OD	Connector	Hole	Horz Size	Up ( )	Offset
Invert 1	947.77'	0°	0"	24" HDPE	27.8"	Hole 30	30"	32.406"	0"	0"
Invert 2	948.5'	170°	84.544"	18" HDPE	21.2"	Hole 24	24"	25.205"	9.06"	-1.5"
Invert 3	947.77'	250°	126.536"	24" HDPE	27.8"	Hole 30	30"	32.406"	0"	0"
Invert 4										
Invert 5										
Invert 6										
Invert 7										
Invert 8										

RIGHT-SIDE UP VIEW (int. dimensions)

UPSIDE-DOWN VIEW (int. dimensions)

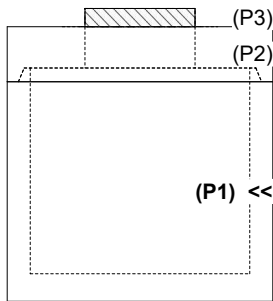
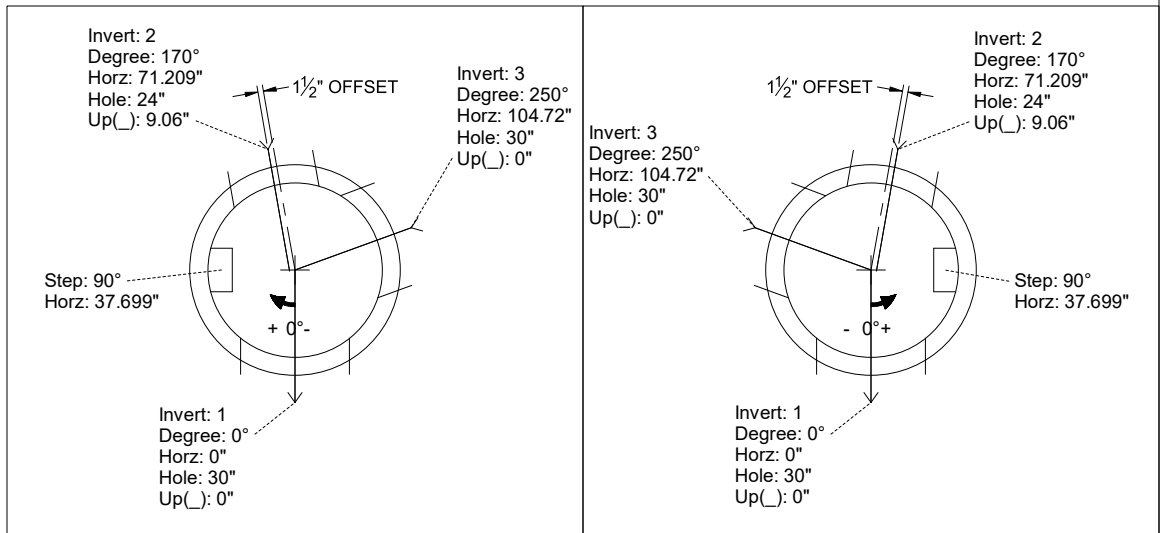

INSIDE WALL DIMENSIONS

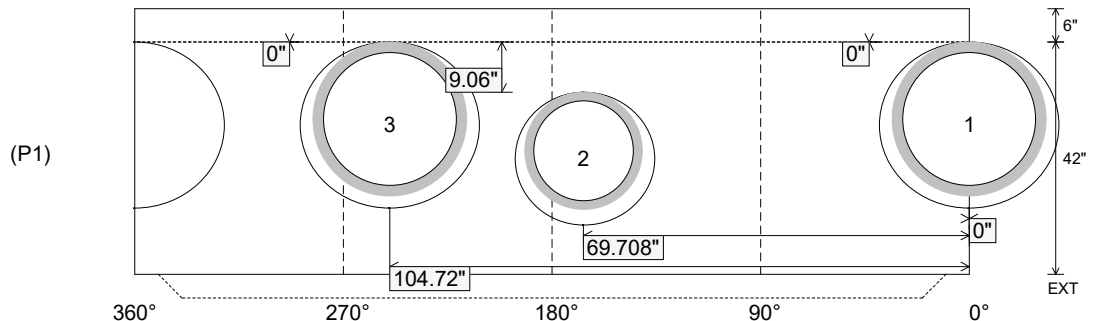

Coating (Int):  
 Coating (Ext):

Seam Up: Tongue  
 Seam Dn: n/a

Wall Thickness: 5"  
 Floor Height: 6"

Height (Int): 42"  
 Height (Ext): 48"

Weight (Net): 3435 lb  
 Volume (Net): 0.88cu.yd