

Job Name: 25-4686 Fivestar 6585
 Job Location: Monticello, KY
 Contractor: Weddle Enterprises, Inc

Plant: 100
 1/24/2026 3:32:05 PM

Tech: J. Horsley - A
 PC: Celina Goff



Structure ID: 3 (4)

P1 MH048BA54

MH BASE T/n

P4) 24" x 24" - CASTING HEIGHT - 4"	0 lb
P3) 24" x 24" - GRADE RING F/F - 3"	258 lb
P2) 48" - MH FLAT TOP w/24"x24" Hole F/G - 12"	1500 lb
P1) 48" - MH BASE T/n - 54"	4458 lb
1) 48" - Conseal CS-102 1.00"	0 lb
2) 24" x 24" - Conseal CS-102 1.00"	0 lb
1) Hole - 30	0 lb
2) Hole - 10	0 lb
1) Hole - 24	0 lb
1) Hole - 14	0 lb
4) MH Step ML-10-TDS-NCR - 10"	0 lb
Structure Total:	6215 lb

Structure Notes:
 1. PER ASTM C-478 SPECIFICATIONS
 2. CONCRETE: 4,000 PSI AT 28 DAYS
 3. REINFORCEMENT: PER ASTM A615
 4. NO STORM INVERT
 5. STEPS AT 230 DEGREES
 6. HOE 280T FRAME & GRATE SUPPLIED BY OTHERS

Rim: 955.85' Rim to Invert: 6.05' Slack: 1.5" Sump: 1.9" Step Position: 230

Position	Elev	Angle	Ext. (cw)	Pipe	Pipe OD	Connector	Hole	Horz Size	Up ()	Offset
Invert 1	949.8'	0°	0"	24" HDPE	27.8"	Hole 30	30"	32.406"	0"	0"
Invert 2	953.1'	10°	5.061"	8" PVC SDR35	8.5"	Hole 10	10"	10.074"	41.25"	0"
Invert 3	949.8'	125°	63.268"	18" HDPE	21.2"	Hole 24	24"	25.133"	0.3"	0"
Invert 4	951'	190°	96.168"	6" PVC SDR35	6.25"	Hole 10	10"	10.074"	16.175"	0"
Invert 5	949.8'	285°	144.251"	10" HDPE	11.4"	Hole 14	14"	14.207"	1.2"	0"
Invert 6										
Invert 7										
Invert 8										

RIGHT-SIDE UP VIEW (int. dimensions)

UPSIDE-DOWN VIEW (int. dimensions)

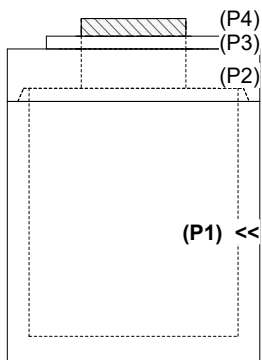
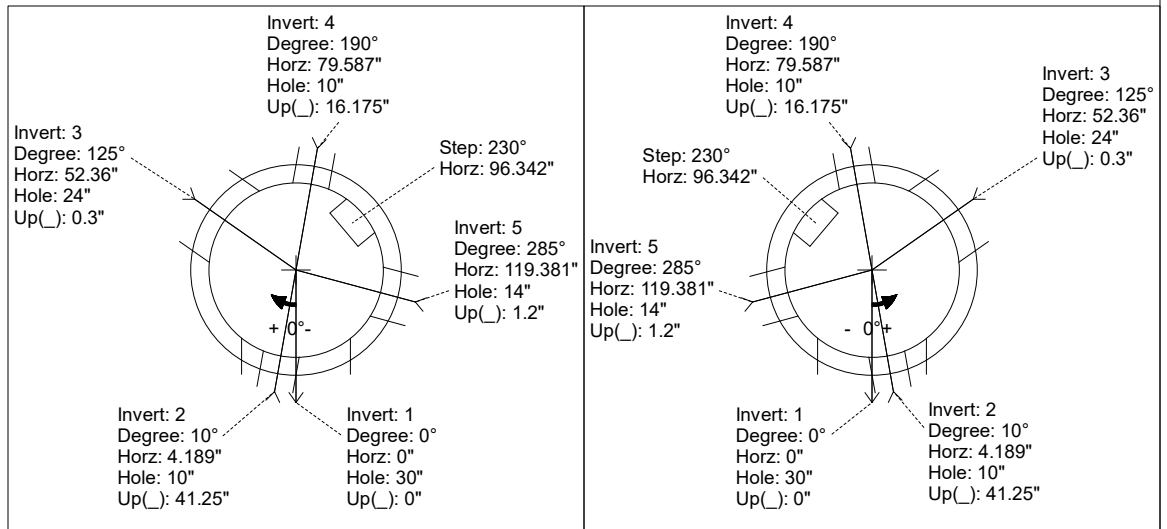

INSIDE WALL DIMENSIONS

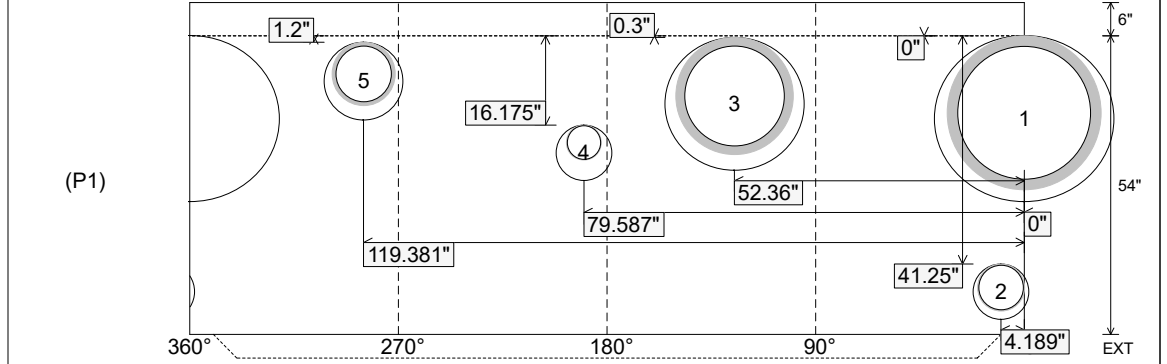

Coating (Int): Coating (Ext):	Seam Up: Tongue Seam Dn: n/a	Wall Thickness: 5" Floor Height: 6"	Height (Int): 54" Height (Ext): 60"	Weight (Net): 4458 lb Volume (Net): 1.14cu.yd
----------------------------------	---------------------------------	----------------------------------------	----------------------------------------	--------------------------------------------------