

Job Name: 25-4679 - 877300 Kentucky Eagle  
 Job Location: Bowling Green, KY  
 Contractor: Contech Engineering Solutions

Plant: Beaver Dam

Tech: J. Coppage

12/11/2025 11:21:43 AM

PC: T. Sekula



**Structure ID: 10-CS-5**

**P2 MH060RSVF**

**MH RISER Custom Ht**

- P4) 30" - CASTING HEIGHT - 0"
- P3) 60" - MH FLAT TOP SPEC. (30" CASTING CAST IN) - 13"
- P2) 60" - MH RISER Custom Ht - 68"
- P1) 60" - MH BASE - 18"
- 1) ASSEMBLY REQUIRED
- 1) CVSTENCILING
- 1) This Structure Includes a Cast-in Item
- 2) 60" - Conseal CS-102 1.00"
- 2) Hole - 24

Structure Notes:  
 (4" TALL CASTING PROVIDED BY OTHERS)  
 CASTING FRAME TO BE CAST INTO THE TOP SLAB  
 CONTECH'S LOGO AS WELL AS THE  
 INLET AND THE OUTLET MUST BE  
 STENCILED ONTO THE STRUCTURE  
 LIFTING ANCHORS TO BE INTALLED  
 ON THE OUTSIDE OF THE STRUCTURE  
 ICAST TO INSTALL THE INTERNALS

Structure Total: 13833 lb

Rim: 495.66' Rim to Invert: 3.33' Slack: -0.92" Sump: 58.12" Step Position:

Position	Elev	Angle	Ext. (cw)	Pipe	Pipe OD	Connector	Hole	Horz Size	Up ( )	Offset
Invert 1	492.33'	270°	169.646"	18" HDPE	21.2"	Hole 24	24"	24.691"	32.37"	0"
Invert 2	492.33'	90°	56.549"	18" HDPE	21.2"	Hole 24	24"	24.691"	32.37"	0"
Invert 3										
Invert 4										
Invert 5										
Invert 6										
Invert 7										
Invert 8										

**RIGHT-SIDE UP VIEW (int. dimensions)**

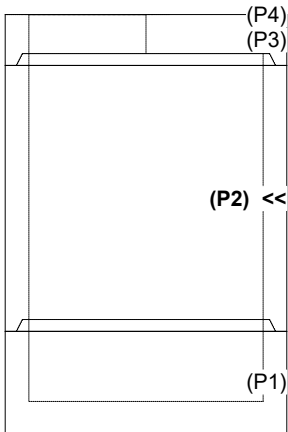

Invert: 2  
 Degree: 90°  
 Horz: 47.124"  
 Hole: 24"  
 Up( ): 32.37"

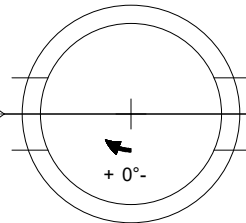

Invert: 1  
 Degree: 270°  
 Horz: 141.372"  
 Hole: 24"  
 Up( ): 32.37"

**INSIDE WALL DIMENSIONS**

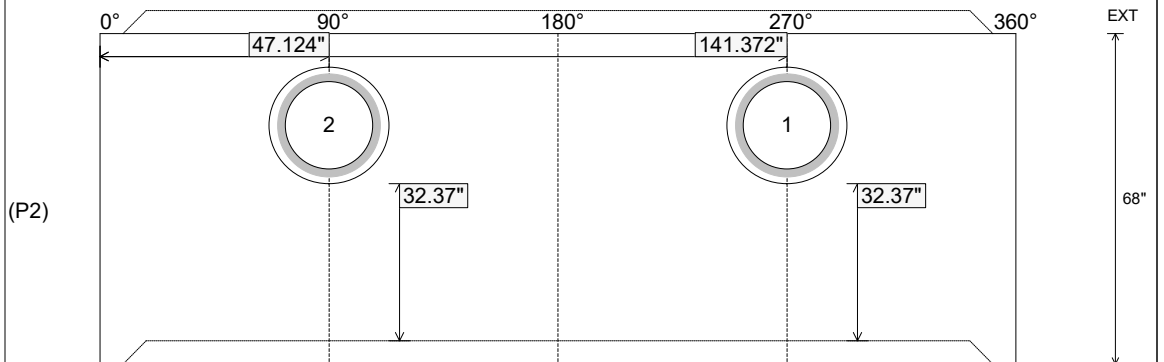

Coating (Int):  
 Coating (Ext):

Seam Up: Tongue  
 Seam Dn: Groove

Wall Thickness: 6"  
 Floor Height: 0"

Height (Int): 68"  
 Height (Ext): 68"

Weight (Net): 6632 lb  
 Volume (Net): 1.69cu.yd