

Job Name: 25-4677 - 870550 Murray State University
 Job Location: Murray, KY
 Contractor: Contech Engineering Solutions

Plant: Beaver Dam

12/11/2025 11:08:04 AM

Tech: J. Coppage

PC: T. Sekula



Structure ID: 10-CS-4

P2 MH048RS60S

MH RISER NO STEPS

- P4) 30" - CASTING HEIGHT - 4"
- P3) 48" - MH FLAT LID w/30in ECC Hole - 12"
- P2) 48" - MH RISER NO STEPS - 60"
- P1) 48" - MH BASE - 18"
- 1) ASSEMBLY REQUIRED
- 1) CVSTENCILING
- 2) 48" - Conseal CS-102 1.00"
- 1) Hole - 24
- 1) Hole - 20

Structure Notes:
 (4" TALL CASTING PROVIDED BY OTHERS)
 LIFTING ANCHORS TO BE INSTALLED ON THE OUTSIDE OF THE STRUCTURE
 ICAST TO INSTALL THE INTERNALS
 CONTECH'S LOGO AS WELL AS THE INTELTA AND OUTLET MUST BE STENCILED ONTO THE STRUCTURE

Structure Total: 7860 lb

Rim: 538.3' Rim to Invert: 3.7' Slack: 1.4' Sump: 51' Step Position:

Position	Elev	Angle	Ext. (cw)	Pipe	Pipe OD	Connector	Hole	Horz Size	Up ()	Offset
Invert 1	534.6'	270°	136.659"	18" HDPE	21.2"	Hole 24	24"	25.133"	25.75"	0"
Invert 2	534.6'	127°	64.28"	15" HDPE	17.6"	Hole 20	20"	20.629"	26.25"	0"
Invert 3										
Invert 4										
Invert 5										
Invert 6										
Invert 7										
Invert 8										

RIGHT-SIDE UP VIEW (int. dimensions)

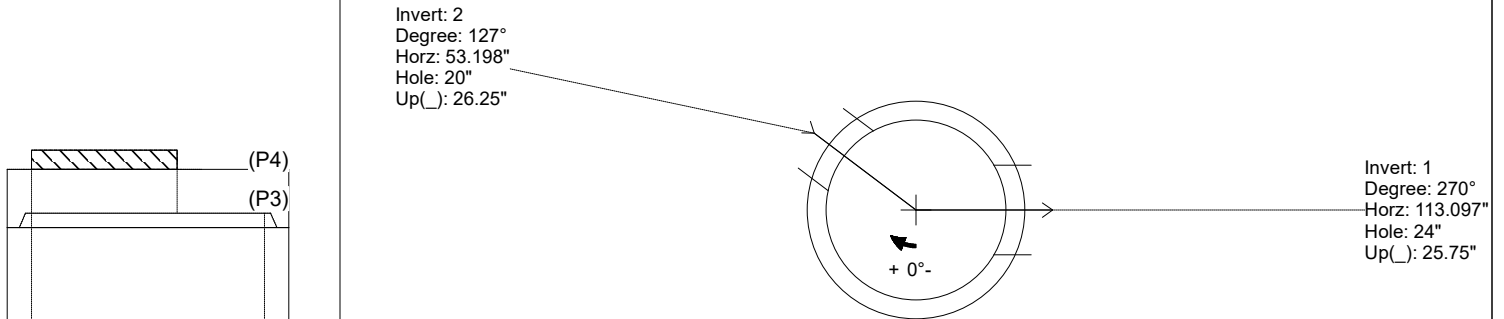

INSIDE WALL DIMENSIONS

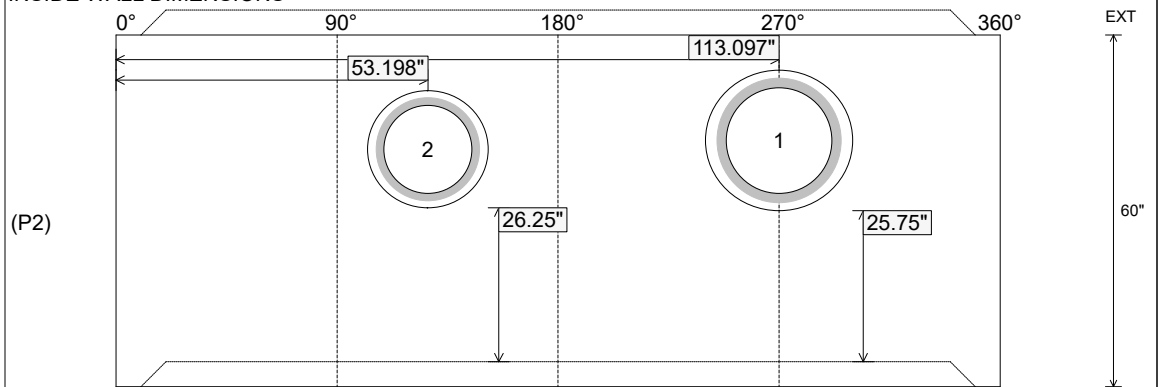

Coating (Int):
 Coating (Ext):

Seam Up: Tongue
 Seam Dn: Groove

Wall Thickness: 5"
 Floor Height: 0"

Height (Int): 60"
 Height (Ext): 60"

Weight (Net): 3859 lb
 Volume (Net): 0.99cu.yd