

Job Name: 25-4668 - Single Pressure Zone Project
 Job Location: La Grange, KY
 Contractor: Connhurst, LLC

Plant: 100

Tech: J. Horsley - A

2/20/2026 1:23:23 PM

PC: Erica Bradley



Structure ID: 54668 (3)

P1 BX072072-08BA-VH

BOX BASE 8inW, 8inF, Variable Ht F/n

- P3) 36" x 36" - HATCH (CAST FLUSH) - 3"
- P2) 72" x 72" - CB FLAT TOP 8"W w/36"X36 Hatch F/F - 8"
- P1) 72" x 72" - BOX BASE 8inW, 8inF, Variable Ht F/n - 72"
- 1) HATCH (Alum.) - HALLIDAY H1W 36"x36"
- 1) This Structure Includes a Cast-in Item - Halliday H1W 36" x 36" Hatch
- 1) SPECIAL Pre-Assembly of Internal Material Required
- 1) SECONDARY POUR
- 1) 72" x 72" - Conseal CS-102 1.00" (Double)
- 1) 36" x 36" - Conseal CS-102 1.00" (Double)
- 2) Hole - 8
- 6) MH Step ML-10-TDS-NCR - 10"

0 lb
 4655 lb
 20578 lb
 235 lb
 0 lb
 0 lb
 0 lb
 0 lb
 0 lb
 0 lb
 0 lb
 0 lb
 0 lb
 0 lb

 25468 lb

- Structure Notes:
1. PER ASTM C-913 SPECIFICATIONS
 2. CONCRETE: 5,000 PSI AT 28 DAYS
 3. REINFORCEMENT: #5 BAR @ 8" C.C. E.W. (GRADE 60) - 2" MIN. REBAR CLEARANCE (TYP)
 4. MANHOLE STEPS REQUIRED AS SHOWN
 5. PRE-ASSEMBLY OF INTERNAL COMPONENTS TO BE PERFORMED BY ICAST
 6. LIFTERS: 4 EA. 5CA18 CONAC A-ANCHORS FOR PLANT & FIELD HANDLING - INSTALLED AS SHOWN

FIRST POUR (FLOOR): 5,179 LBS
SECOND POUR (WALLS): 15,399 LBS

Structure Total: 25468 lb

Rim: 6.667' Rim to Invert: 5.667' Slack: 0" Sump: 12" Step Position: 0°

Position	Elev	Angle	Ext. (cw)	Pipe	Pipe OD	Connector	Hole	Horz Size	Up ()	Offset
Invert 1	1'	90°	44"	4" DI	4.75"	Hole 8	8"	8"	10"	0"
Invert 2	1'	270°	44"	4" DI	4.75"	Hole 8	8"	8"	10"	0"

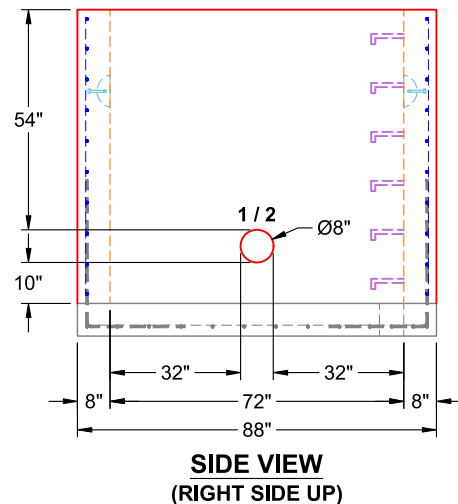
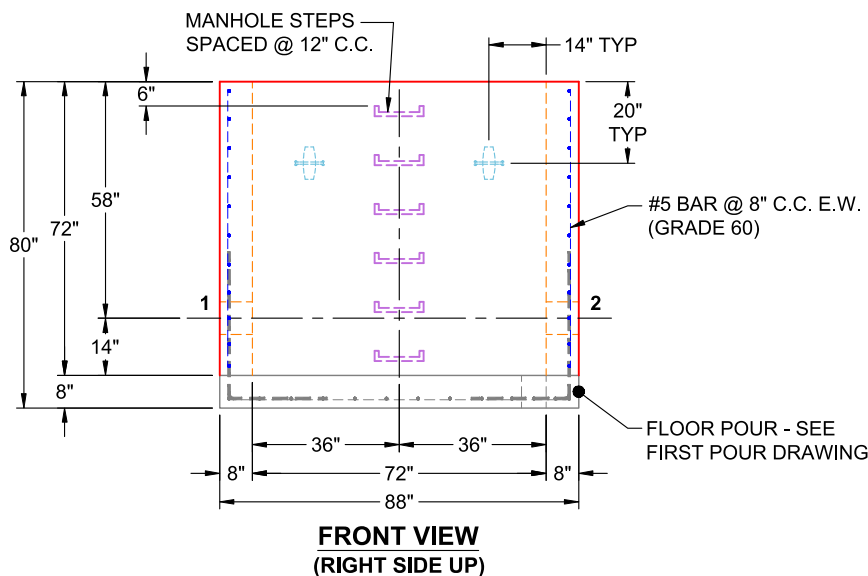
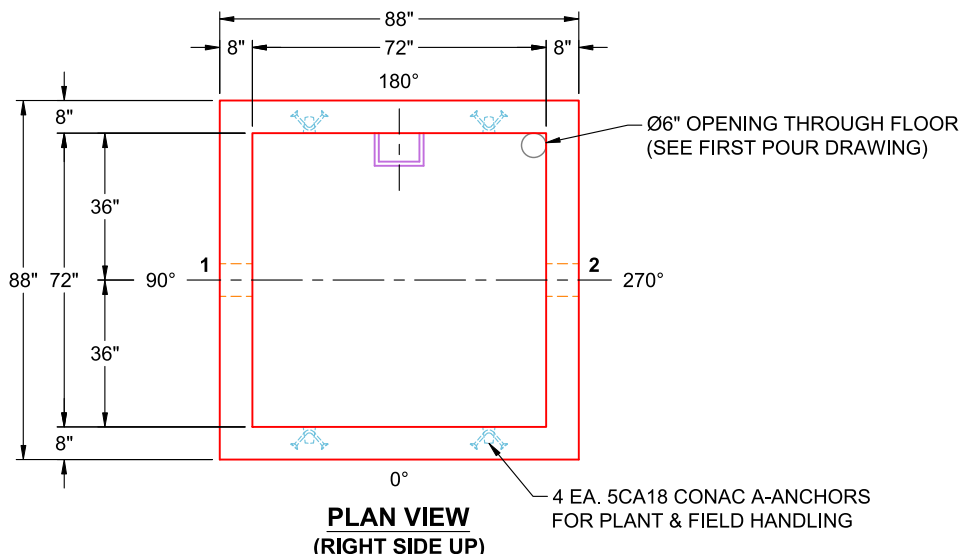

Coating (Int): Coating (Ext):	Seam Up: Flat Seam Dn: n/a	Wall Thickness: 8" Floor Height: 8"	Height (Int): 72" Height (Ext): 80"	Weight (Net): 20578 lb Volume (Net): 5.26cu.yd
----------------------------------	-------------------------------	--	--	---

SPECIAL PRE-ASSEMBLY PERFORMED BY ICAST
JOB NUMBER: 25-4668
STRUCTURE: 54668 (3)

LEGEND

- | | |
|--|--|
| ① 2 - 6"X6" TAPPING SLEEVE & VALVE | ⑨ 2 - 2" BRONZE GATE VALVE (LUNKENHEIMER #2151) |
| ② 1 - 6" INSERTION VALVE | ⑩ 2" BRASS PIPE |
| ③ 2 - 6" 90° M.J. BEND | ⑪ 1 - 2" PRV BERMAD MODEL WW-2"-T20-EN-P2-Y-C-A5-EB-NN-INV |
| ④ 2 - 6"X4" M.J. REDUCER | ⑫ 2 - PRESSURE GAUGE W/ VALVE ASHCROFT 4 1/2" DURAGAUGE W/ 0-200 psi RANGE |
| ⑤ CONCRETE SUPPORT AS REQUIRED | ⑬ MANHOLE STEPS |
| ⑥ 1 - 4" BERMAD 10F STRAINER | ⑭ 4" PVC DRAIN LINE, DRAIN TO DAYLIGHT (LOCATION TO BE FIELD VERIFIED) |
| ⑦ 1 - 4" PRV BERMAD MODEL WW-4"-T20-EN-P2-Y-C-A5-EB-NN-INV | ⑮ FLANGED COUPLING ADAPTOR |
| ⑧ 4" D.I. PIPE | ⑯ 6" D.I. PIPE |

NOTE : PRV INLET PRESSURE 90 psi
 OUTLET PRESSURE 10 psi

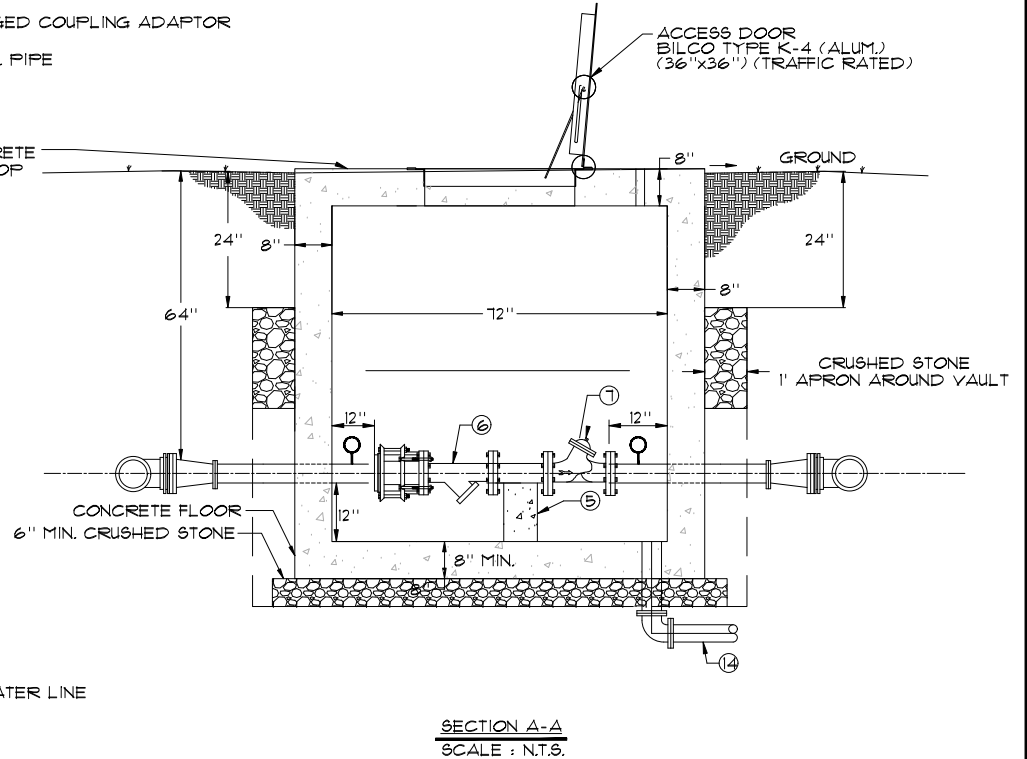
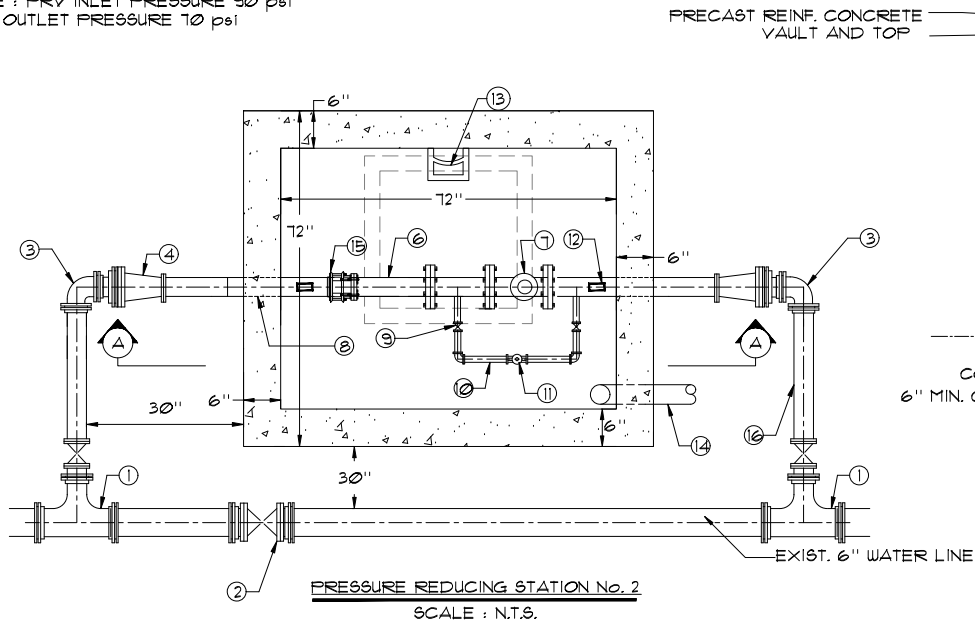

NO.		DATE	REVISIONS	CHK'D	APPR'D	DATE
PROJECT: 4313.000-021 DATE: NOV. 2025 SCALE: NTS						
DESIGNED BY	NAME	DATE				
DRAWN BY	DPS	11/2025				
CHECKED BY	BGB	11/2025				
RECORD DUGS.						



3 HMB CIRCLE
 FRANKFORT, KENTUCKY
 (502) 695-9800
 (502) 695-9810 FAX

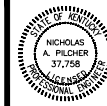

LAGRANGE UTILITIES COMMISSION
SINGLE PRESSURE ZONE PROJECT
OLDHAM COUNTY, KENTUCKY
CRYSTAL DRIVE
PRESSURE REDUCING VALVE VAULT

SHEET
 SD2