

**Job Name: 25-4665 - Buckhorn WTP**  
**Job Location: Hazard, KY**  
**Contractor: Smith Contractors, Inc.**

PC: E. Bradley  
 TECH: J. Horsley  
 Plant: 100



Structure ID: **54665 (4)**  
 Spec: Sanitary  
 Type: Wet Well  
 Size: 144"

Rim: 755'  
 Invert: 709'  
 Rim to Invert: 46'

Sump: 12"  
 Floor (Top): 708"  
 Floor Height: 0"

Floor (Bot): 708"  
 Overall Height: 47"  
 Slack: 0"

**Structure Notes:**

- PER ASTM C-478 SPECIFICATIONS
- CONCRETE: 4,500 PSI AT 28 DAYS
- REINFORCEMENT:
  - FLAT LID TOP MAT: #4 BAR @ 12" C.C. E.W. (GRADE 60)
  - FLAT LID BOTTOM MAT: #5 BAR @ 6" C.C. E.W. (GRADE 60)
  - INTERMEDIATE SLAB: DOUBLE MAT #5 BAR @ 12" C.C. E.W. (GRADE 60)
  - RISERS: PER ASTM A615
- NO INVERT CHANNEL
- NO STEPS
- 2 EA. HALLIDAY W1R 48" X 36" HATCHES & 1 EA. HALLIDAY W1R 30" X 30" HATCH SUPPLIED BY OTHERS - TO BE CAST INTO FLAT LID
- LADDER SUPPLIED BY OTHERS
- 4 EA. 3"W X 24"L STAINLESS STEEL STRAPS SUPPLIED BY ICAST
- 2 EA. DUCTILE IRON VENT PIPES SUPPLIED BY OTHERS

**STRUCTURE SUMMARY:**

P10) 48" x 36" - HATCH (CAST FLUSH) - 0"	0 lb
P9) 144" - MH FLAT TOP w/(2) 48"x36" & (1) 30"x30" Hatches F/G - 18"	19644 lb
P8) 144" - MH RISER Custom Ht T/G - 81"	43581 lb
P7) 144" - MH RISER Custom Ht T/G - 81"	43581 lb
P6) 144" - MH RISER Custom Ht T/G - 81"	43581 lb
P5) 144" - MH RISER Custom Ht T/G - 81"	43581 lb
P4) 144" - MH RISER Custom Ht T/G - 74"	39815 lb
P3) 144" - MH RISER Custom Ht T/G - 74"	39815 lb
P2) 144" - MH RISER Custom Ht T/F - 74"	39445 lb
P1) 144" - P.I.P. BY OTHERS - BTM SLAB F/n - 0"	0 lb
7) JOINT WRAP - 12" WD x 144" MAC WRAP	0 lb
1) SECONDARY POUR - Intermediate Slab (In Riser P5)	13500 lb
1) This Structure Includes a Cast-in Item - Hatches (Supplied by Others)	0 lb
4) Stainless Steel Strap - 3"W x 24"L Stainless Steel Strap	0 lb
8) 144" - Conseal CS-231 1.00" (Double)	0 lb
1) A-Lok - 0630	1 lb
<b>Structure Total:</b>	<b>326544 lb</b>

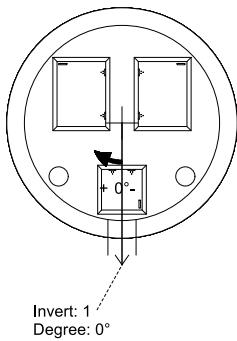

Position	Elev	Angle	Pipe	Pipe OD	Hole	Connector	Up (")	Ref
Rim	755'							
Reducer								
Invert 1	709'	0°	18" DI	19.5"	20.75"	A-Lok 0630	10.625"	P2
Invert 2								
Invert 3								
Invert 4								
Invert 5								
Invert 6								
Invert 7								
Invert 8								

**Cast (Int. Dim.) - Interior Dimensions**

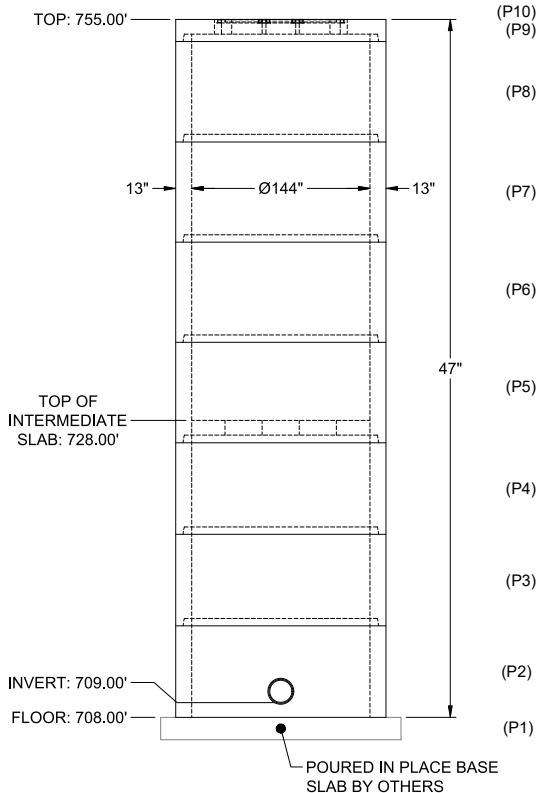
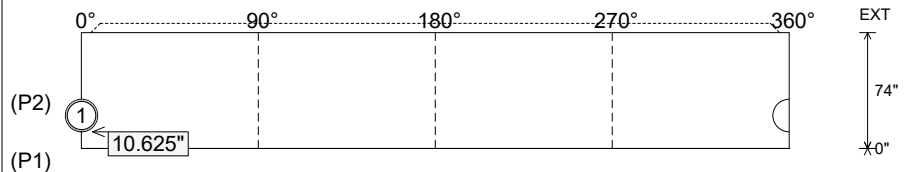

Submittal Drawing  
 4/9/2026 3:05:12 PM

SUBMITTAL  
 APPROVED BY: