

Job Name: 25-4620 - Oak Grove Sewer Main Extension
 Job Location: Oak Grove, KY
 Contractor: Winwater Hartford KY Co.

Plant: 100

Tech: J. Hosrley - F

12/15/2025 10:19:13 AM

PC: A. Chambers



Structure ID: 1 (2)

P2 MH048CN42CDARED

ECC CONE w/ 24" HOLE, w/ConBlock-CDA Red F/G

- P3) 24" - CASTING HEIGHT - 7"
- P2) 48" - ECC CONE w/ 24" HOLE, w/ConBlock-CDA Red F/G - 42"
- P1) 48" - MH BASE w/ConBlock-CDA Red T/n - 36"
- 1) JOINT WRAP - 0.065"x6"x50" CONSEAL CS212
- 1) JOINT WRAP PRIMER - CONSEAL CS-75 (1 gal.)
- 1) ADMIXTURE CONBLOCK CDA RED
- 1) 48" - MH INVERT CHANNEL w/ConBlock-CDA Red - FULL HEIGHT
- 1) CASTING - JBS 1140M F/C SANITARY
- 1) 48" - Conseal CS-102 1.00" (Double)
- 2) PSX - 12-08 DD
- 1) PSX - 12-06 DD
- 7) MH Step ML-10-TDS-NCR - 10"

0 lb
 3116 lb
 3701 lb
 0 lb
 0 lb
 0 lb
 1440 lb
 250 lb
 0 lb
 16 lb
 8 lb
 0 lb

 Structure Total: 8532 lb

- Structure Notes:
1. PER ASTM C-478 SPECIFICATIONS
 2. CONCRETE: 4,000 PSI AT 28 DAYS
 3. REINFORCEMENT: PER ASTM A615
 4. INVERT CHANNEL REQUIRED
 5. CONBLOCK CDA RED ADMIXTURE REQUIRED
 6. STEPS AT 0 DEGREES
 7. CASTING BY ICAST (JBS 1140M FRAME & COVER "SANITARY")
 8. ICAST TO PROVIDE DOUBLE BANDS FOR BOOTS

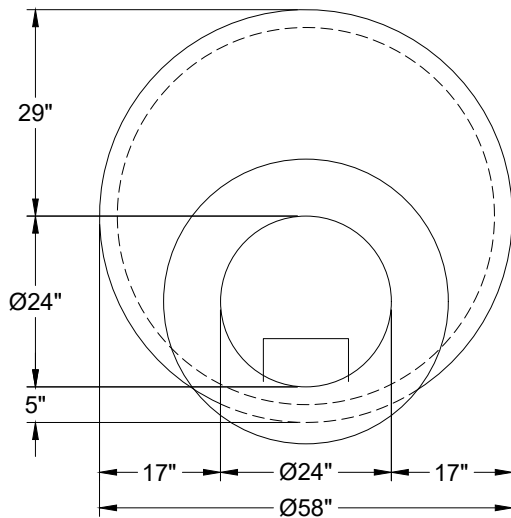

48" - ECC CONE w/ 24" HOLE, w/ConBlock-CDA Red F/G - 42" - (P2)

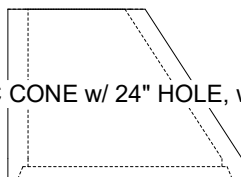

Coating (Int):
 Coating (Ext):

Seam Up: Flat
 Seam Dn: Groove

Wall Thickness: 5"

Height (Ext): 42"

Weight (Net): 3116 lb
 Volume (Net): 0.8cu.yd