

Job Name: 25-4616 - 781070 Bohannon Tract 5
 Job Location: Louisville, KY
 Contractor: Contech Engineering Solutions

Plant: Beaver Dam

12/4/2025 12:31:38 PM

Tech: J. Coppage

PC: T. Sekula



Structure ID: 10-CS-8

P4 MH096LD17SP

MH FLAT TOP SPEC. (2 - 24"Ø HOLES)

- P5) 24" - CASTING HEIGHT - 4"
- P4) 96" - MH FLAT TOP SPEC. (2 - 24"Ø HOLES) - 17"
- P3) 96" - MH RISER NO STEPS - 48"
- P2) 96" - MH RISER NO STEPS - 96"
- P1) 96" - MH MONOBASE 13F, Custom Ht - 24"
- 1) ASSEMBLY REQUIRED
- 1) CVSTENCILING
- 3) 96" - Conseal CS-102 1.00"
- 2) Hole - 28

0 lb	Structure Notes:
10015 lb	(4" TALL CASTING PROVIDED BY OTHERS)
11958 lb	
22831 lb	ICAST TO INSTALL THE INTERNALS
17113 lb	
0 lb	CONTECH'S LOGO AS WELL AS THE INLET
0 lb	AND THE OUTLET MUST BE STENCILED
0 lb	ONTO THE STRUCTURE

Structure Total:	61916 lb

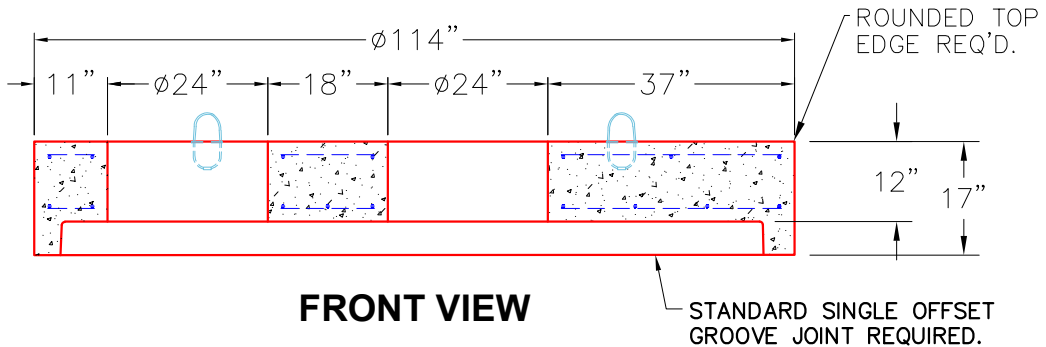
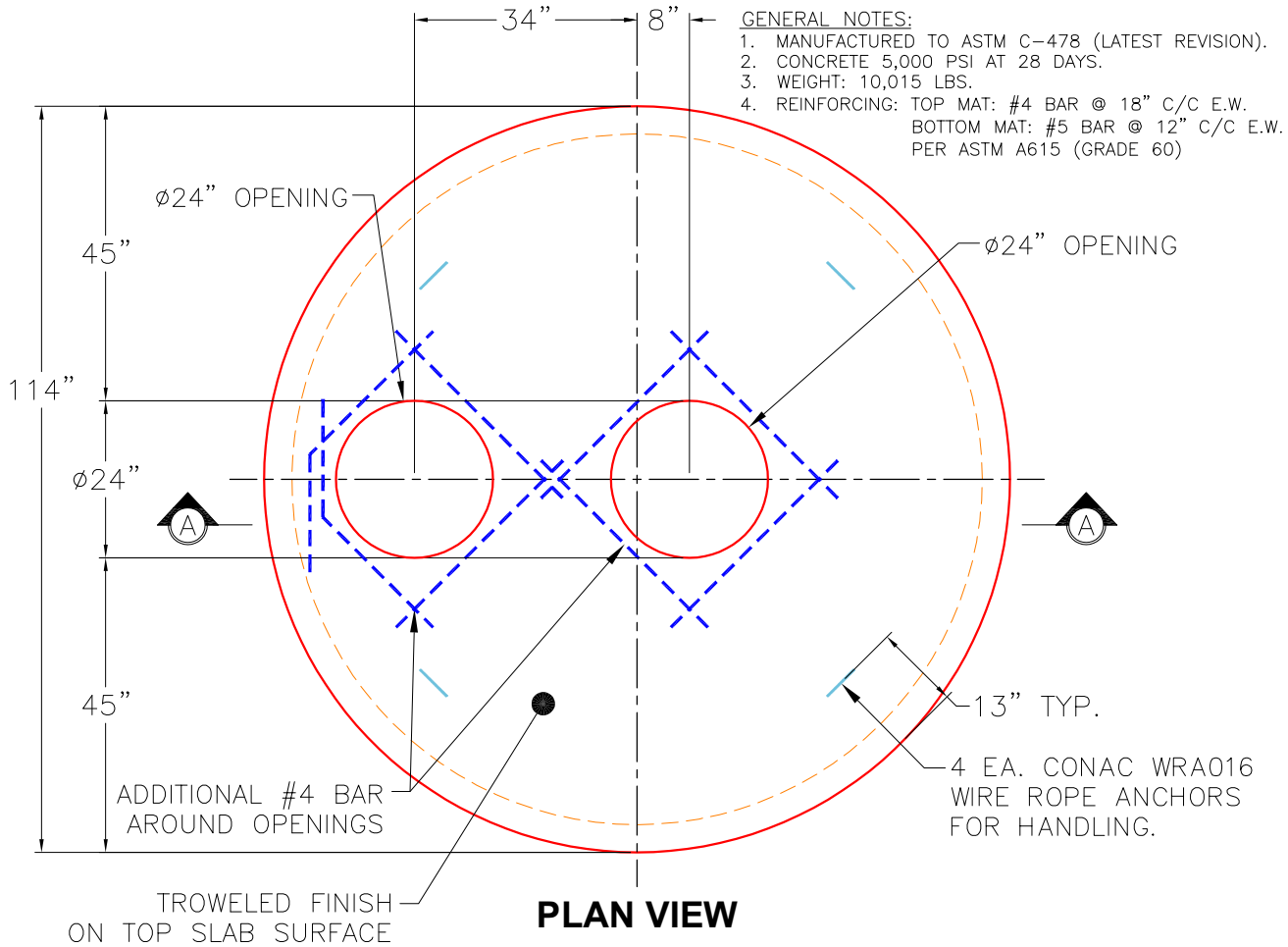

Coating (Int):	Seam Up: Flat	Wall Thickness: 9"	Height (Ext): 17"	Weight (Net): 10015 lb
Coating (Ext):	Seam Dn: Groove			Volume (Net): 2.56cu.yd