

Job Name: 25-4595 - 4015 Utah Ave  
 Job Location: Nashville, TN 37209  
 Contractor: Hayes Pipe Supply

Plant: 100

2/26/2026 12:07:31 PM

Tech: Jared - F

PC: E. Bradley



**Structure ID: A2 (3)**

**P1 MH048BAVF**

**MH BASE Custom Ht T/n**

- P3) 24" - CASTING HEIGHT - 7"
- P2) 48" - CON CONE w/24" HOLE F/G - 24"
- P1) 48" - MH BASE Custom Ht T/n - 34"
- 1) 48" - Conseal CS-102 1.00"
- 2) Hole - 26
- 5) MH Step ML-10-TDS-NCR - 10"

0 lb  
 2252 lb  
 3239 lb  
 0 lb  
 0 lb  
 0 lb  
 -----  
 0 lb

Structure Total: 5491 lb

- Structure Notes:**
1. PER ASTM C-478 SPECIFICATIONS
  2. CONCRETE: 4,000 PSI AT 28 DAYS
  3. REINFORCEMENT: PER ASTM A615
  4. NO STORM INVERT
  5. STEPS AT 228.5 DEGREES
  6. CASTING SUPPLIED BY OTHERS

Rim: 534.07' Rim to Invert: 5.25' Slack: 0.5" Sump: 2.5" Step Position: 228.5°

| Position | Elev    | Angle | Ext. (cw) | Pipe           | Pipe OD | Connector | Hole | Horz Size | Up ( ) | Offset |
|----------|---------|-------|-----------|----------------|---------|-----------|------|-----------|--------|--------|
| Invert 1 | 528.82' | 0°    | 0"        | 18" RCP B WALL | 23"     | Hole 26   | 26"  | 27.476"   | 0"     | 0"     |
| Invert 2 | 528.92' | 97°   | 49.125"   | 18" RCP B WALL | 23"     | Hole 26   | 26"  | 27.476"   | 1.25"  | 0"     |
| Invert 3 |         |       |           |                |         |           |      |           |        |        |
| Invert 4 |         |       |           |                |         |           |      |           |        |        |
| Invert 5 |         |       |           |                |         |           |      |           |        |        |
| Invert 6 |         |       |           |                |         |           |      |           |        |        |
| Invert 7 |         |       |           |                |         |           |      |           |        |        |
| Invert 8 |         |       |           |                |         |           |      |           |        |        |

RIGHT-SIDE UP VIEW (int. dimensions)

UPSIDE-DOWN VIEW (int. dimenions)

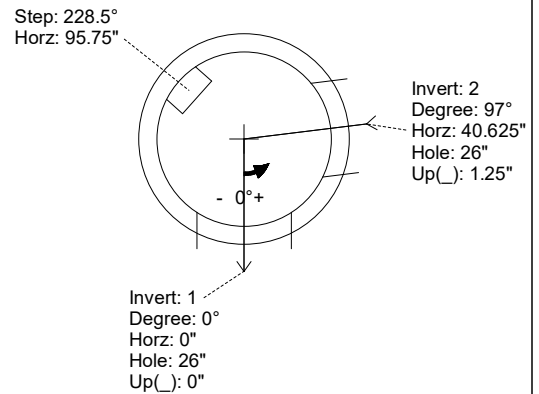
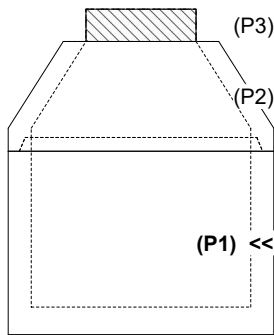

INSIDE WALL DIMENSIONS

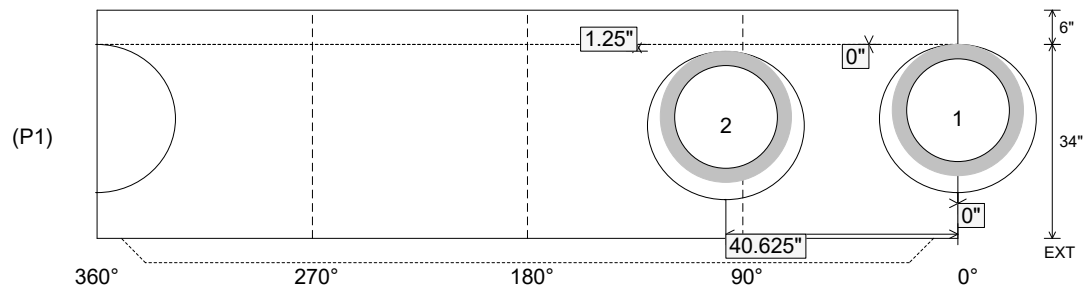

Coating (Int):  
 Coating (Ext):

Seam Up: Tongue  
 Seam Dn: n/a

Wall Thickness: 5"  
 Floor Height: 6"

Height (Int): 34"  
 Height (Ext): 40"

Weight (Net): 3239 lb  
 Volume (Net): 0.83cu.yd