

Job Name: 25-4593 - 823277 Central Ramp Expansion BNA
 Job Location: Nashville, TN
 Contractor: Contech Engineering Solutions

Plant: Beaver Dam, KY
 12/4/2025 1:55:10 PM

Tech: J. Coppage
 PC: T. Sekula



Structure ID: 030-CDS5678-10-C

P7 GR6

GRADE RING

- P9) 24" - CASTING HEIGHT - 4"
- P8) 24" - GRADE RING - 4"
- P7) 24" - GRADE RING - 6"
- P6) 120" - MH FLAT TOP SPEC. (2 - 24"Ø HOLES) - 18"
- P5) 120" - MH RISER Custom Ht - 40"
- P4) 120" - MH RISER - 96"
- P3) 120" - MH RISER Custom Ht - 82"
- P2) 120" - MH RISER Custom Ht - 38"
- P1) 120" - MH BASE SLAB - 6"
- 1) CVSTENCILING
- 1) SECONDARY POUR - Separation Slab*
- 5) 120" - Conseal CS-102 1.00"
- 2) Hole - 42

0 lb
 270 lb
 405 lb
 16223 lb
 15195 lb
 33863 lb
 31150 lb
 14435 lb
 14760 lb
 0 lb
 10363 lb
 0 lb
 0 lb

 Structure Total: 136664 lb

Structure Notes:

1. PER ASTM C-478 SPECS
2. CONCRETE: 7,000 PSI AT 28 DAYS
3. REINFORCEMENT: PER ASTM A615 (GRADE 60)
4. 2 EA. CASTINGS PROVIDED BY OTHERS
5. LIFTING HOOKS TO BE INSTALLED ON THE INSIDE OF THE STRUCTURE
6. CONTECH'S LOGO AS WELL AS INLET AND OUTLET MUST BE STENCILED ONTO STRUCTURE
7. BASE SLAB, BASE SECTION, AND CONTROL SECTION
HAVE ALREADY BEEN PRODUCED.
8. INTERNALS TO BE INSTALLED BY OTHERS

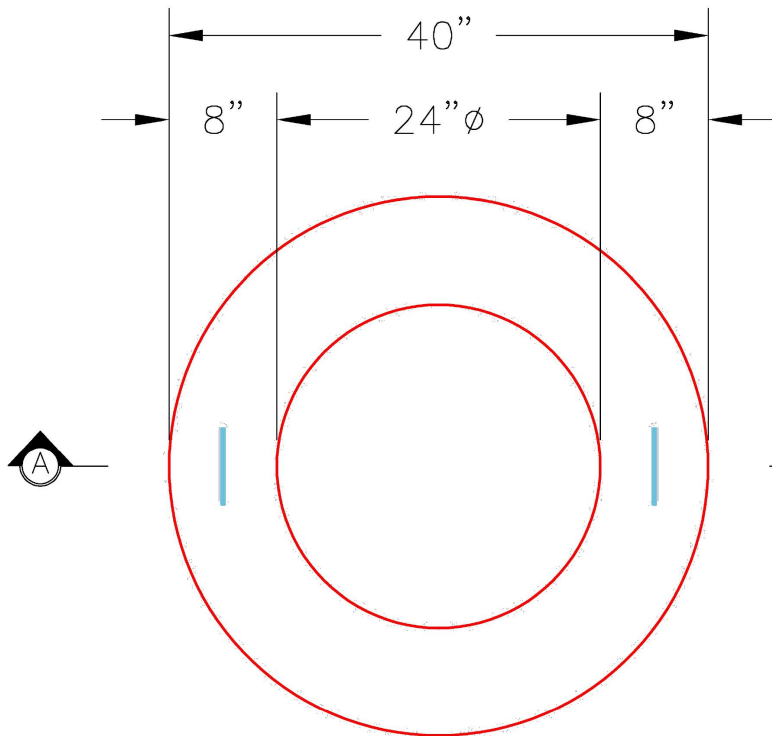

2 TOTAL REQUIRED

PLAN VIEW

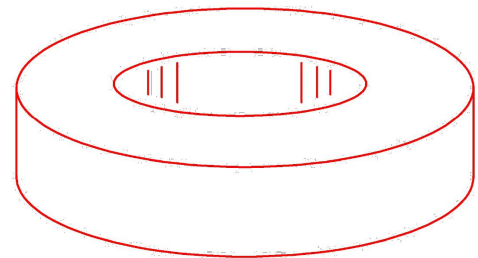

ISOMETRIC VIEW

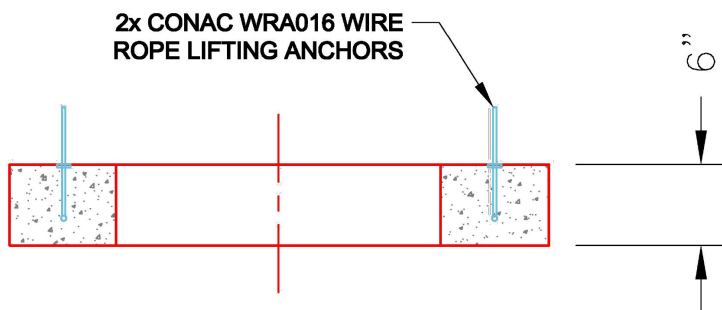

SECTION A-A

Coating (Int):
 Coating (Ext):

Seam Up: Flat
 Seam Dn: Flat

Wall Thickness: 8"

Height (Ext): 6"

Weight (Net): 405 lb
 Volume (Net): 0.1cu.yd