

Job Name: 25-4593 - 823277 Central Ramp Expansion BNA
Job Location: Nashville, TN
Contractor: Contech Engineering Solutions

PC: T. Sekula
 TECH: J. Coppage
 Plant: Beaver Dam, KY



Structure ID: **025-CDS5678-10-C**
 Spec: Storm-Pipe Centered
 Type: STM.MH Trans. to 72in
 Size: 120"

Rim: 554.59'
 Invert: 519.29'
 Rim to Invert: 35.3'

Sump: 156.96"
 Floor (Top): 506.21'
 Floor Height: 8"

Floor (Bot): 505.543'
 Overall Height: 49.083'
 Slack: -0.44"

- Structure Notes:**
- PER ASTM C-478 SPECS
 - CONCRETE: 7,000 PSI AT 28 DAYS
 - REINFORCEMENT: PER ASTM A615 (GRADE 60)
 - 2 EA. CAST-IN CASTINGS PROVIDED BY OTHERS
 - CASTINGS TO BE CAST INTO FLAT LID FLANGE SIDE UP
- SPECIAL NOTES:**
- LIFTING HOOKS TO BE INSTALLED ON THE INSIDE OF THE STRUCTURE
 - CONTECH'S LOGO AS WELL AS INLET & OUTLET MUST BE STENCILED ONTO STRUCTURE
 - INTERNALS TO BE INSTALLED BY OTHERS

STRUCTURE SUMMARY:

P11) 24" - CASTING HEIGHT - 0"	0 lb
P10) 72" - MH FLAT TOP SPEC. (2 - 24"Ø HOLES) - 25"	8609 lb
P9) 72" - MH RISER - 60"	8747 lb
P8) 72" - MH RISER - 84"	12246 lb
P7) 72" - MH RISER - 84"	12246 lb
P6) 120" - MH Transition Slab 72" Spec. w/(2) 24" Holes - 22"	22335 lb
P5) 120" - MH RISER - 84"	31909 lb
P4) 120" - MH RISER - 96"	33046 lb
P3) 120" - MH RISER Custom Ht - 90"	34189 lb
P2) 120" - MH RISER - 36"	13675 lb
P1) 120" - MH SEPARATE BASE-T (142" OD) - 8"	17421 lb
1) CVSTENCILING	0 lb
1) This Structure Includes a Cast-in Item - (2 Ea. Castings)	0 lb
1) SECONDARY POUR - Separation Slab*	10292 lb
5) 120" - Conseal CS-102 1.00"	0 lb
4) 72" - Conseal CS-102 1.00"	0 lb
2) Hole - 48	0 lb
Structure Total:	204714 lb

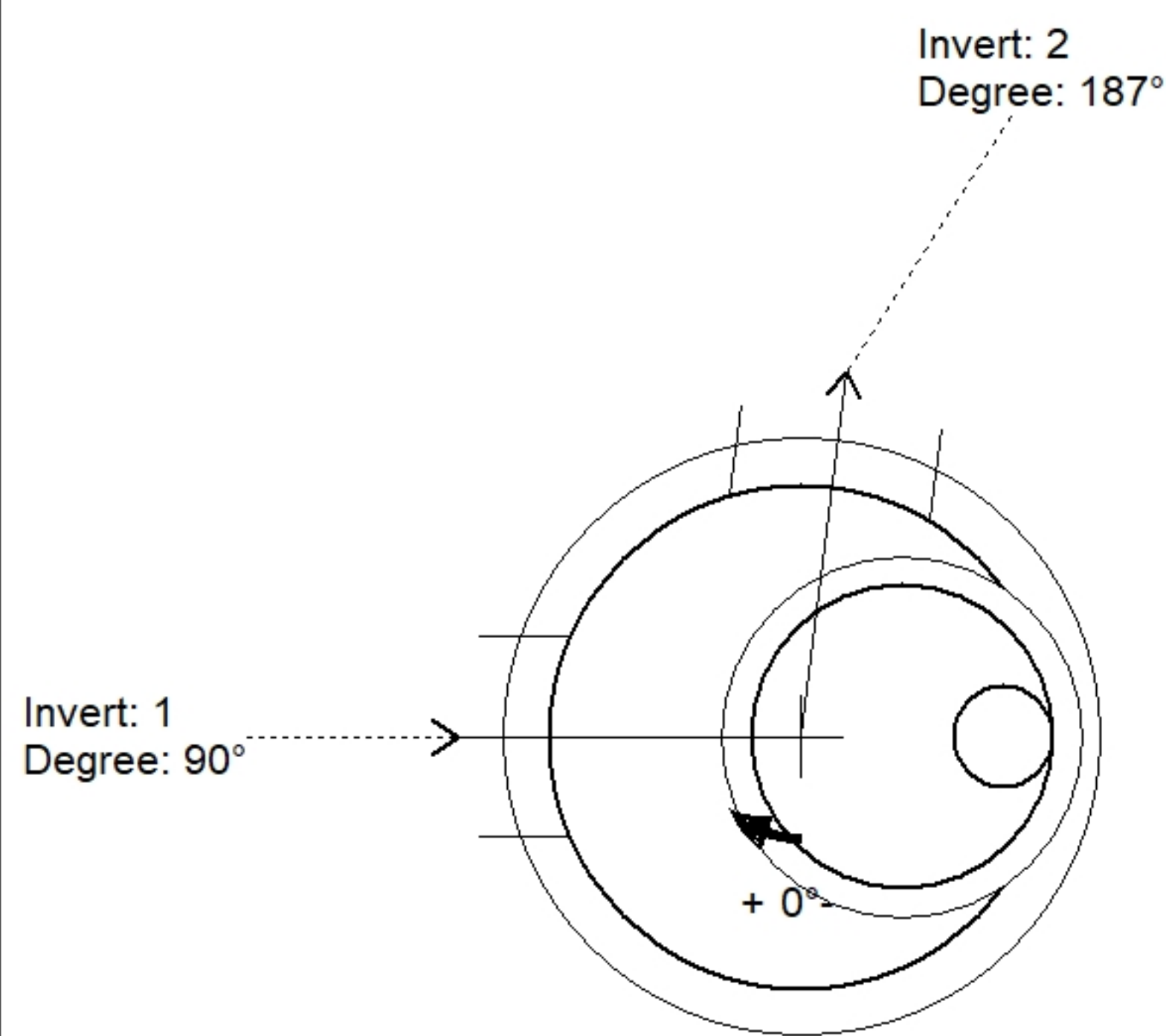

Position	Elev	Angle	Pipe	Pipe OD	Hole	Connector	Up (')	Ref
Rim	554.59'							
Reducer	531.71'							
Invert 1	519.29'	90°	36" RCP B WALL	44"	48"	Hole 48	18.96"	P4
Invert 2	519.29'	187°	36" RCP B WALL	44"	48"	Hole 48	18.96"	P4
Invert 3								
Invert 4								
Invert 5								
Invert 6								
Invert 7								
Invert 8								

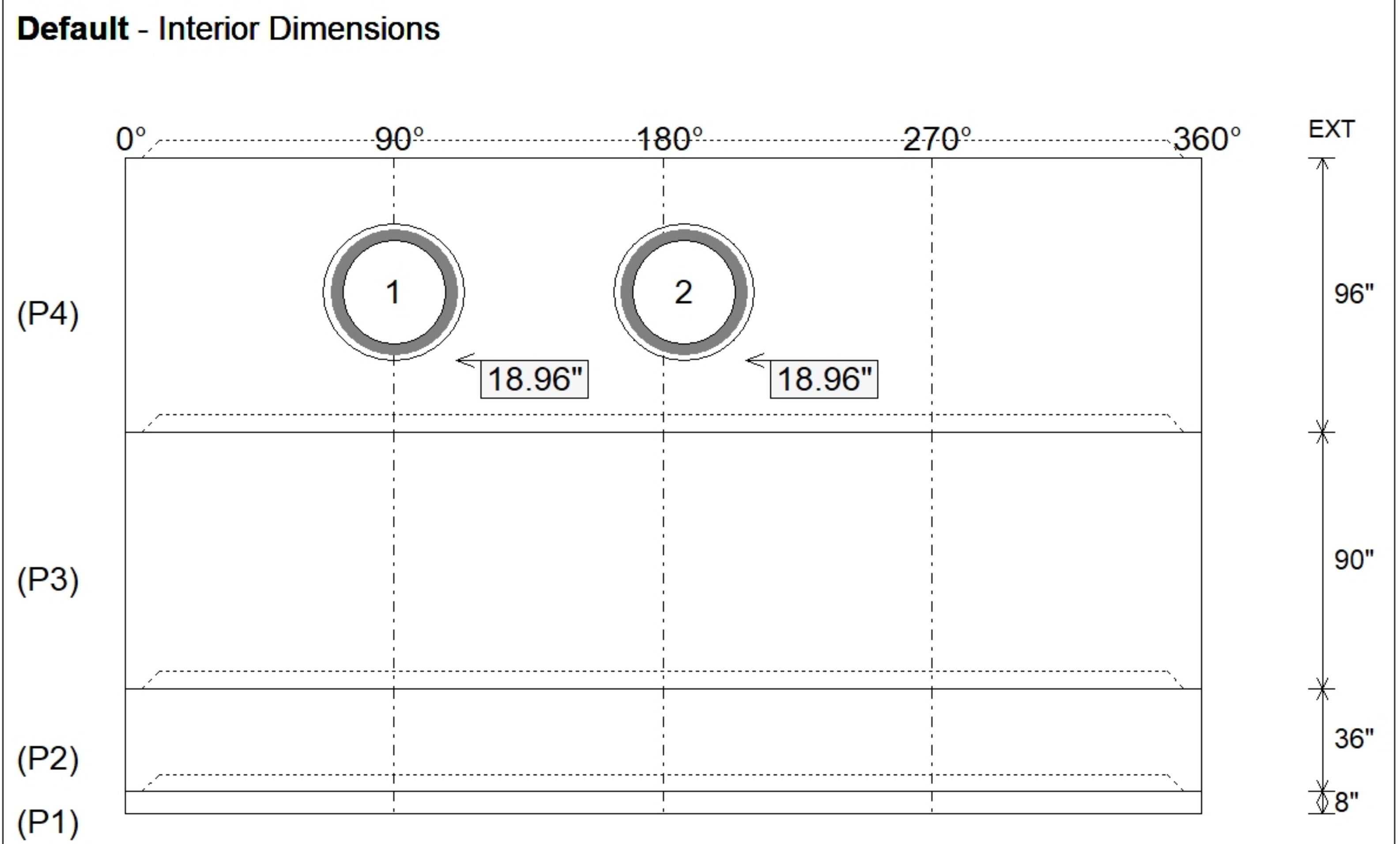
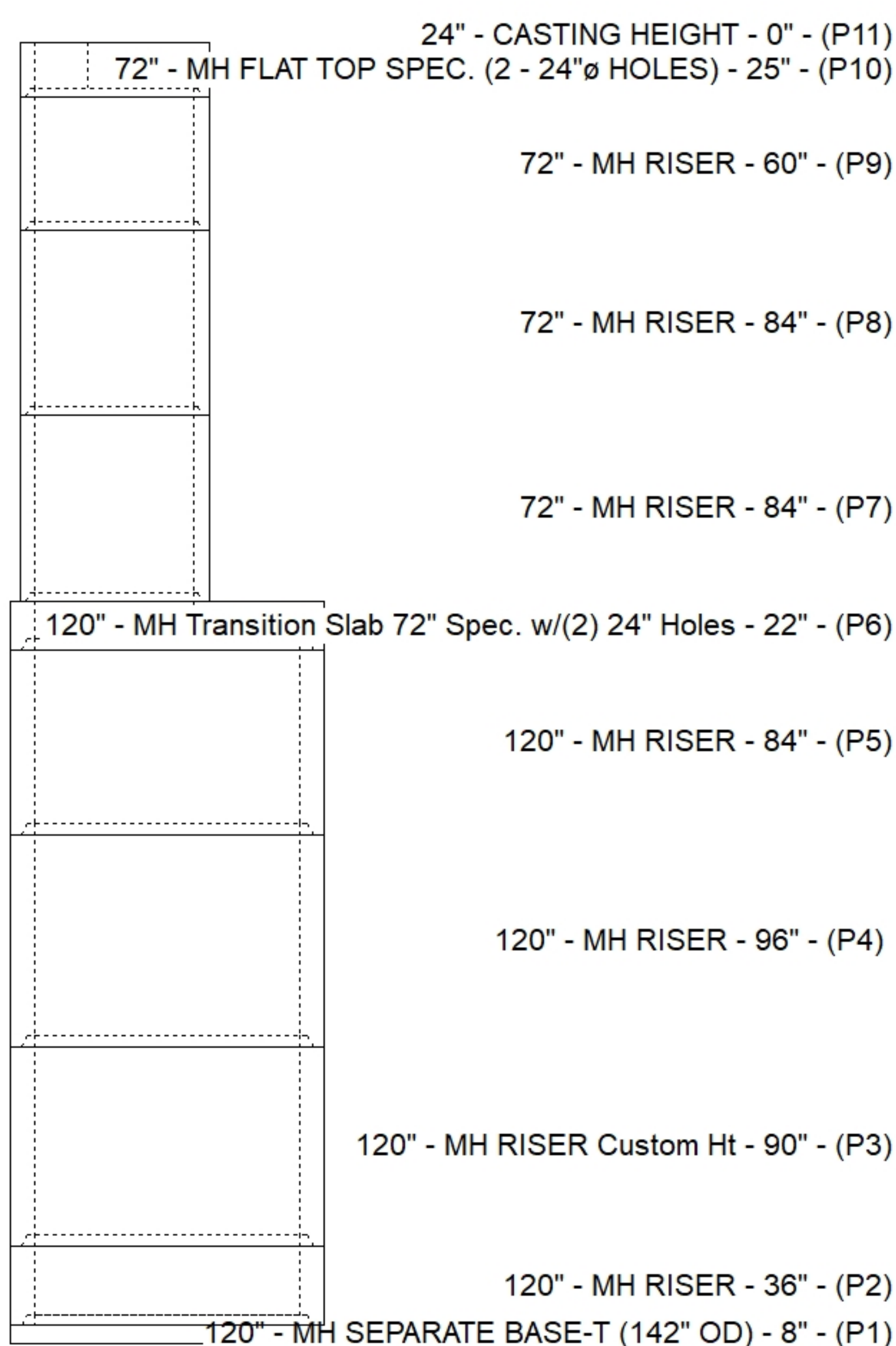

Submittal Drawing
 12/2/2025 2:57:38 PM

SUBMITTAL
 APPROVED BY: