

Job Name: 25-4593 - 823277 Central Ramp Expansion BNA  
 Job Location: Nashville, TN  
 Contractor: Contech Engineering Solutions

Plant: Beaver Dam, KY  
 12/2/2025 11:09:47 AM

Tech: J. Coppage  
 PC: T. Sekula



**Structure ID: 025-CDS5678-10-C**

**P2 MH120RS36 MH RISER**

- P11) 24" - CASTING HEIGHT - 0"
- P10) 72" - MH FLAT TOP SPEC. (2 - 24"Ø HOLES) - 25"
- P9) 72" - MH RISER - 60"
- P8) 72" - MH RISER - 84"
- P7) 72" - MH RISER - 84"
- P6) 120" - MH Transition Slab 72" Spec. w/(2) 24" Holes - 22"
- P5) 120" - MH RISER - 84"
- P4) 120" - MH RISER - 96"
- P3) 120" - MH RISER Custom Ht - 90"
- P2) 120" - MH RISER - 36"
- P1) 120" - MH SEPARATE BASE-T (142" OD) - 8"
- 1) CVSTENCILING
- 1) This Structure Includes a Cast-in Item - (2 Ea. Castings)
- 1) SECONDARY POUR - Separation Slab\*
- 5) 120" - Conseal CS-102 1.00"
- 4) 72" - Conseal CS-102 1.00"

**\*\*USE REINFORCEMENT  
 INFORMATION PROVIDED  
 BY CONTECH\*\***

- 0 lb
  - 8609 lb
  - 8747 lb
  - 12246 lb
  - 12246 lb
  - 22335 lb
  - 31909 lb
  - 33046 lb
  - 34189 lb
  - 13675 lb
  - 17421 lb
  - 0 lb
  - 0 lb
  - 10292 lb
  - 0 lb
  - 0 lb
- Structure Notes:**
1. PER ASTM C-478 SPECS
  2. CONCRETE: 7,000 PSI AT 28 DAYS
  3. REINFORCEMENT: PER ASTM A615 (GRADE 60)
  4. 2 EA. CAST-IN CASTINGS PROVIDED BY OTHERS
  5. CASTINGS TO BE CAST INTO FLAT LID FLANGE SIDE UP
- SPECIAL NOTES:**
1. LIFTING HOOKS TO BE INSTALLED ON THE INSIDE OF THE STRUCTURE
  2. CONTECH'S LOGO AS WELL AS INLET & OUTLET MUST BE STENCILED ONTO STRUCTURE
  3. INTERNALS TO BE INSTALLED BY OTHERS

2) Rim to Invert: 35.3' Slack: -0.44" Sump: 156.96" Step Position: 0'

Position	Elev	Angle	Ext. (cw)	Pipe	Pipe OD	Structure Total:	Hole	Horz Size	Up (L)	Offset
Invert 1						2047.14 lb				
Invert 2										
Invert 3										
Invert 4										
Invert 5										
Invert 6										
Invert 7										
Invert 8										

RIGHT-SIDE UP VIEW (int. dimensions)

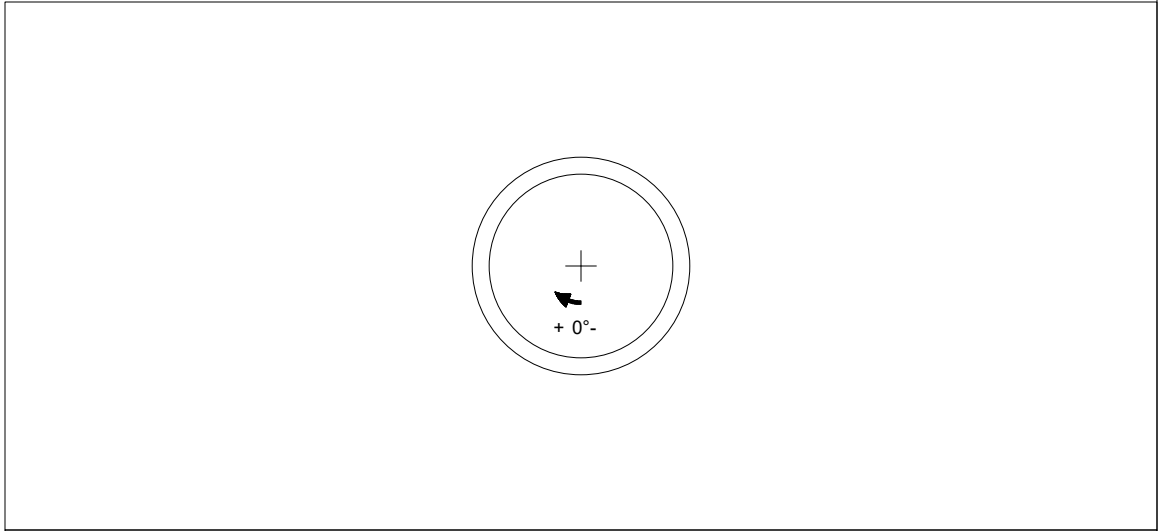
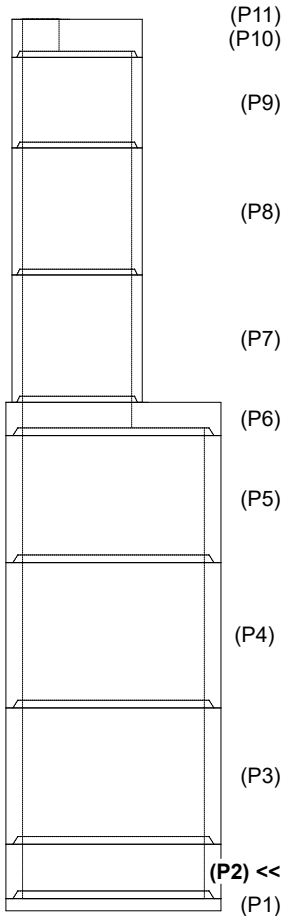

INSIDE WALL DIMENSIONS

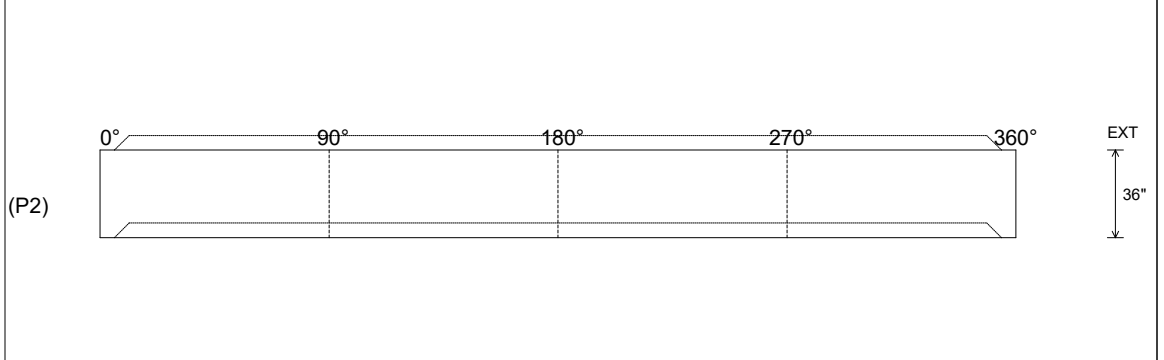

Coating (Int): Coating (Ext):	Seam Up: Tongue Seam Dn: Groove	Wall Thickness: 11" Floor Height: 0"	Height (Int): 36" Height (Ext): 36"	Weight (Net): 13675 lb Volume (Net): 3.49cu.yd
----------------------------------	------------------------------------	---	--	---

# 25-4593 BASE SLAB REINFORCEMENT 025-CDS5678-10-C

**DESIGN NOTE:**

AIRCRAFT LOADING - 80 KIP WHEEL LOAD - 17.19"x12.68" TIRE FOOTPRINT  
 WATER TABLE AT FINISHED GRADE  
 DESIGN CONFORMS TO AASHTO LRFD  
 CONCRETE 28 DAY COMPRESSIVE STRENGTH - 7000 PSI  
 REINFORCEMENT STEEL - 60,000 PSI  
 REBAR MIN SPLICE LENGTHS: #3-17" #4-22" #5-28" #6-33"  
 REBAR MIN BEND DIAMETERS: #3-2.25" #4-3" #5-3.75" #6-4.5"  
 PLACE 4-#4 BAR DIAGONAL AROUND OPENING(S)

823277-25

## REINFORCING STEEL SCHEDULE

MARK	NO.	LENGTH	TYPE	BENDING DIAGRAM O.D.
6A	62	10'-7" MAX	STR.	
4B	24	11'-6" MAX	STR.	

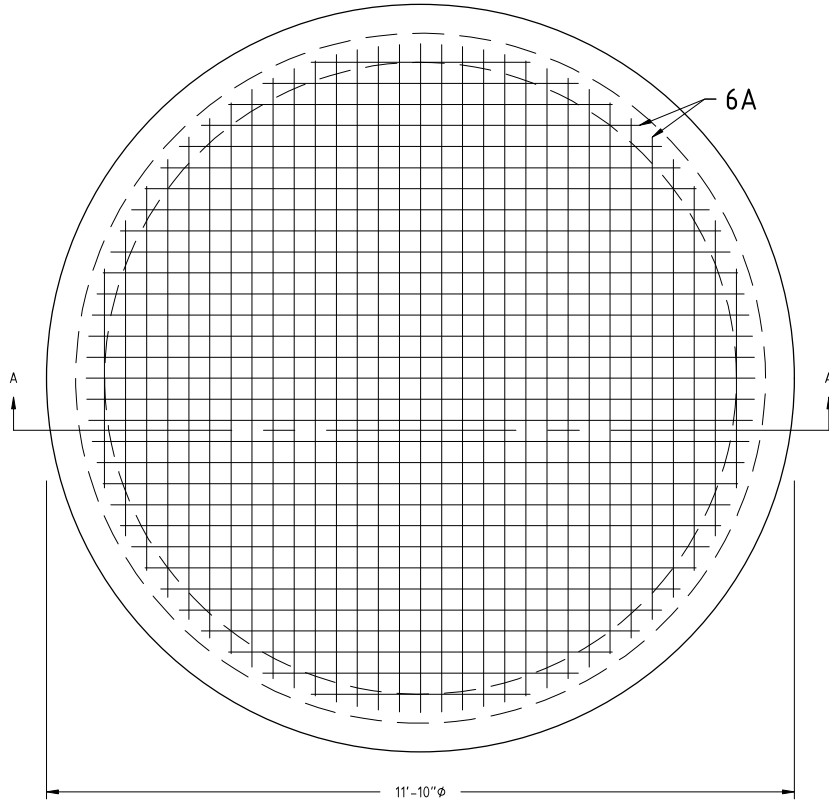

**PLAN VIEW**  
(TOP MAT SHOWN)

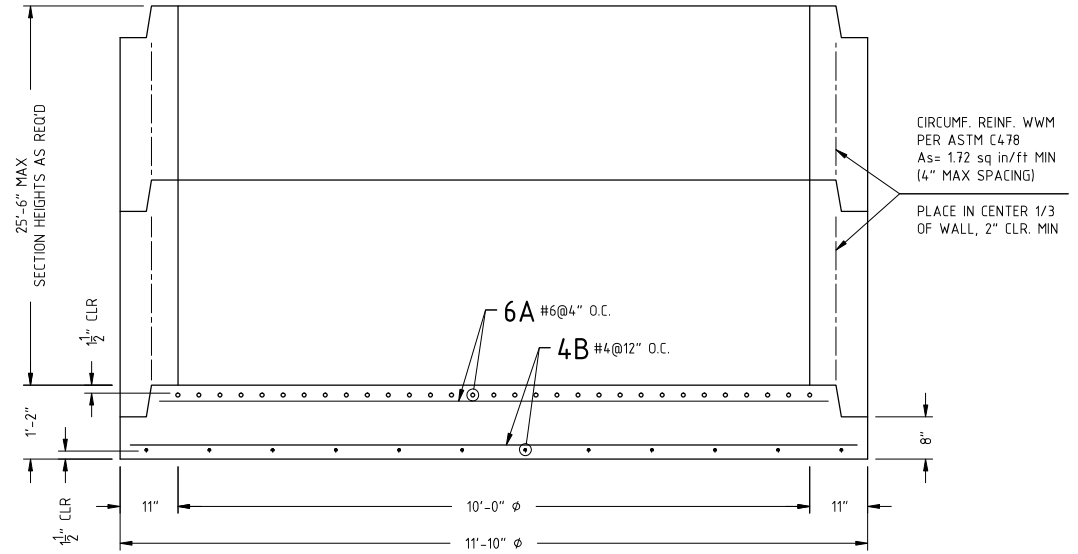

**SECTION A-A**



PROPRIETARY AND CONFIDENTIAL:  
 THE INFORMATION CONTAINED IN THIS DOCUMENT IS THE SOLE PROPERTY OF CONTECH. ANY REPRODUCTION IN PART OR AS A WHOLE WITHOUT THE WRITTEN PERMISSION OF CONTECH IS PROHIBITED.

REVISIONS	
B	
C	
D	
E	

DRAWN BY: T.J.G.  
 DESIGN BY: A.JEFFREY  
 PLANT:  
 SCALE: 1/2" = 1'

CONTECH - CDS - BASESLAB  
 10'-0"Ø  
 REINFORCEMENT

DATE: 10/21/25 11"x17" PAGE 1 OF 1