

Job Name: 25-4593 - 823277 Central Ramp Expansion BNA
 Job Location: Nashville, TN
 Contractor: Contech Engineering Solutions

Plant: Beaver Dam, KY
 12/2/2025 11:09:19 AM

Tech: J. Coppage
 PC: T. Sekula



Structure ID: 020-CDS4040-8-C

P6 MH096LD25SP

MH FLAT TOP SPEC. (2 - 24"Ø F&G)

- P7) 24" - CASTING HEIGHT - 0"
- P6) 96" - MH FLAT TOP SPEC. (2 - 24"Ø F&G) - 25"
- P5) 96" - MH RISER Custom Ht - 46"
- P4) 96" - MH RISER - 72"
- P3) 96" - MH RISER Custom Ht - 53"
- P2) 96" - MH RISER - 36"
- P1) 96" - MH SEPARATE BASE-T (114" OD) - 8"
- 1) CVSTENCILING
- 1) This Structure Includes a Cast-in Item - (2 Ea. Castings)
- 1) SECONDARY POUR - Separation Slab*
- 5) 96" - Conseal CS-102 1.00"
- 2) Hole - 42
- 1) Hole - 36

****USE REINFORCEMENT INFORMATION PROVIDED BY CONTECH****

- | | |
|----------|--|
| 0 lb | Structure Notes: |
| 14787 lb | 1. PER ASTM C-478 SPECS |
| 11459 lb | 2. CONCRETE: 7,000 PSI AT 28 DAYS |
| 14991 lb | 3. REINFORCEMENT: PER ASTM A615 (GRADE 60) |
| 13203 lb | 4. 2 EA. CAST-IN CASTINGS PROVIDED BY OTHERS |
| 8968 lb | 5. CASTINGS TO BE CAST INTO FLAT LID FLANGE |
| 10484 lb | SIDE UP |
| 0 lb | 6. INVERT 2 OFFSET 6" FROM CENTER |
| 0 lb | |
| 6669 lb | SPECIAL NOTES: |
| 0 lb | 1. LIFTING HOOKS TO BE INSTALLED ON |
| 0 lb | THE INSIDE OF THE STRUCTURE |
| 0 lb | 2. CONTECH'S LOGO AS WELL AS INLET & OUTLET |
| 0 lb | MUST BE STENCILED ONTO STRUCTURE |
| 0 lb | 3. INTERNALS TO BE INSTALLED BY OTHERS |

Structure Total: 80562 lb

- GENERAL NOTES:**
1. MANUFACTURED TO ASTM C-478 (LATEST REVISION).
 2. CONCRETE 7,000 PSI AT 28 DAYS.
 3. REINFORCING: USE REINFORCEMENT INFORMATION PROVIDED BY CONTECH. (GRADE 60KSI)
 4. CASTINGS PROVIDED BY OTHERS. FRAMES TO BE CAST INTO THE TOP SLAB FLANGE SIDE UP.

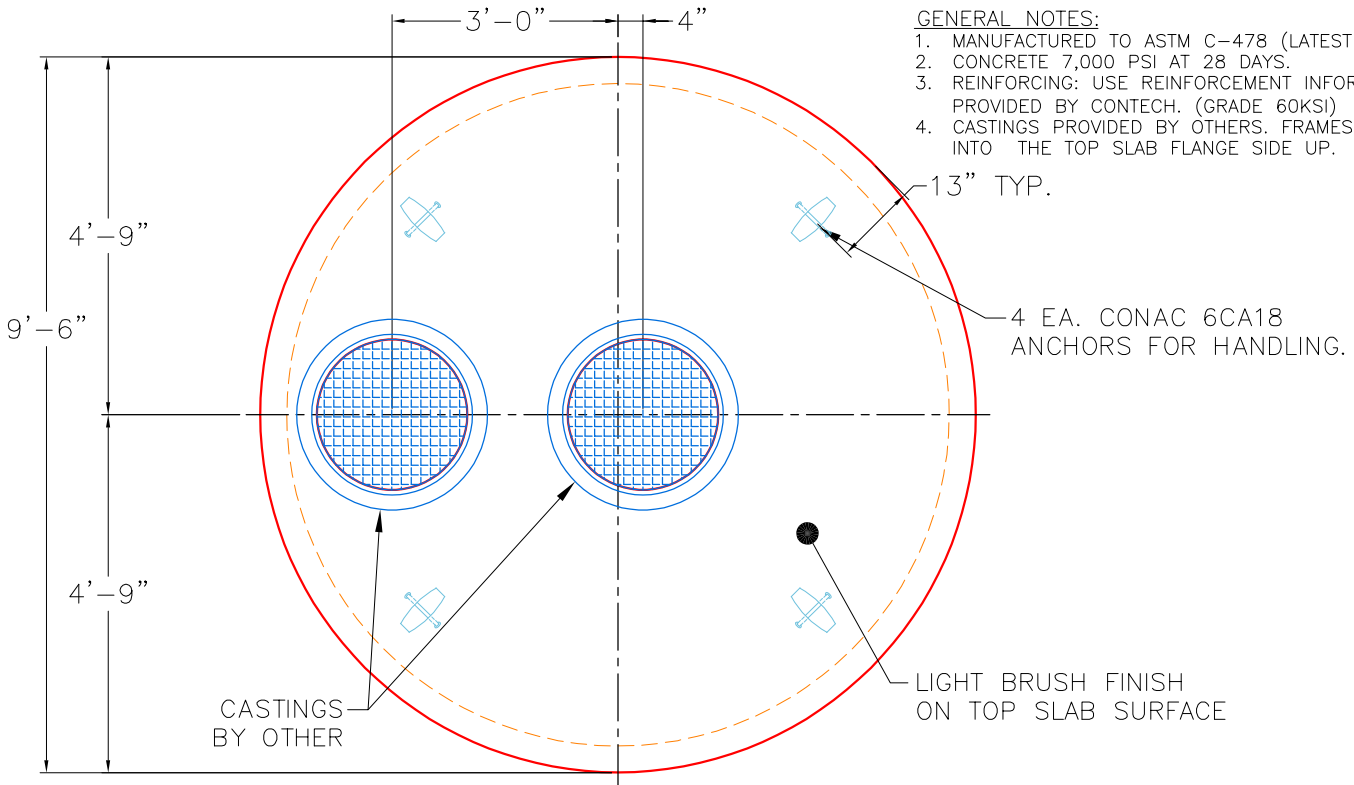

TOP VIEW

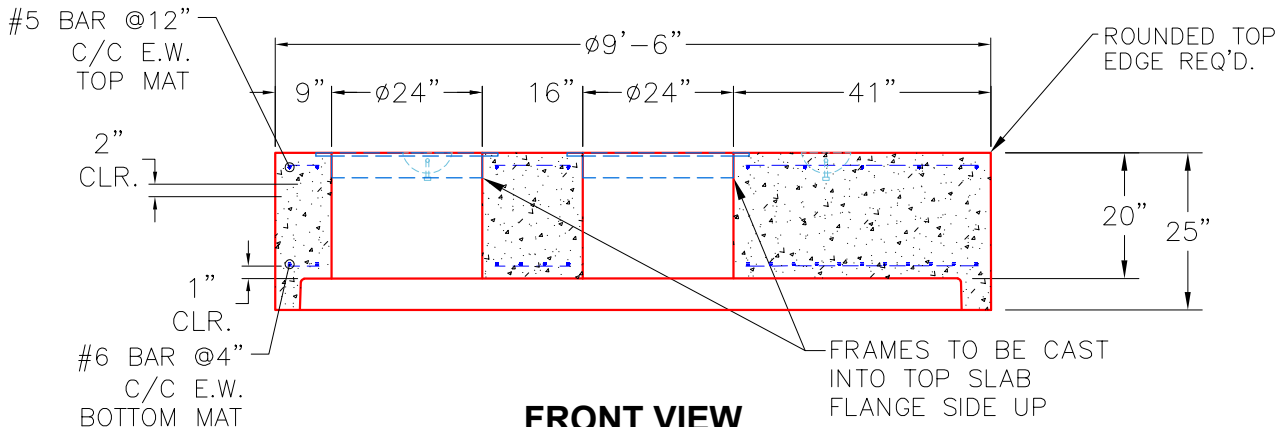

FRONT VIEW

Coating (Int): Coating (Ext):	Seam Up: Flat Seam Dn: Groove	Wall Thickness: 9"	Height (Ext): 25"	Weight (Net): 14787 lb Volume (Net): 3.78cu.yd
----------------------------------	----------------------------------	--------------------	-------------------	---

25-4593 TOP SLAB REINFORCEMENT 020-CDS4040-8-C

DESIGN NOTE:

AIRCRAFT LOADING - 80 KIP WHEEL LOAD - 17.19"x12.68" TIRE FOOTPRINT
 WATER TABLE AT FINISHED GRADE
 DESIGN CONFORMS TO AASHTO LRFD
 CONCRETE 28 DAY COMPRESSIVE STRENGTH - 7000 PSI
 REINFORCEMENT STEEL - 60,000 PSI
 REBAR MIN SPLICE LENGTHS: #3-17" #4-22" #5-28" #6-33"
 REBAR MIN BEND DIAMETERS: #3-2.25" #4-3" #5-3.75" #6-4.5"
 PLACE 4-#4 BAR DIAGONAL AROUND OPENING(S)

823277-20

REINFORCING STEEL SCHEDULE

MARK	NO.	LENGTH	TYPE	BENDING DIAGRAM O.D.
5A	20	9'-3" MAX	STR.	
6B	54	9'-3" MAX	STR.	

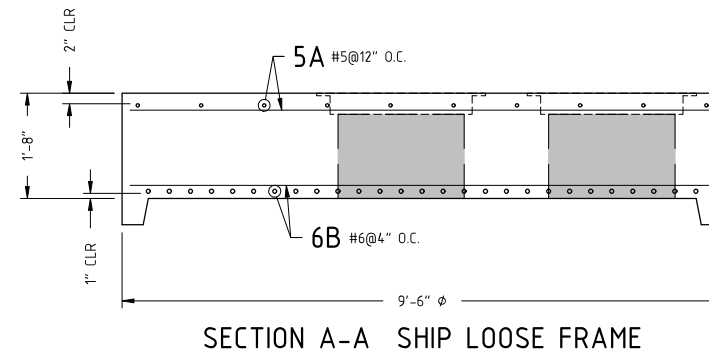
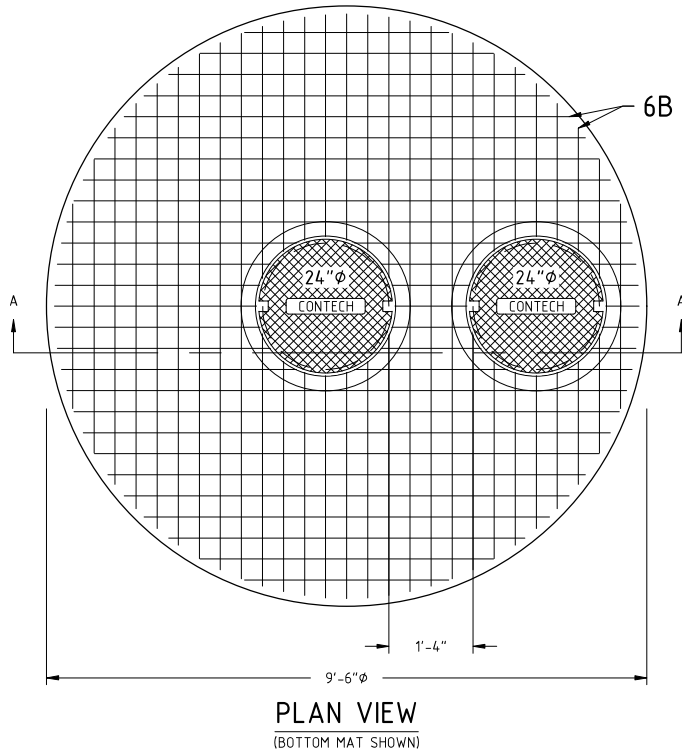

PROPRIETARY AND CONFIDENTIAL:
 THE INFORMATION CONTAINED IN THIS DOCUMENT IS THE SOLE PROPERTY OF CONTECH. ANY REPRODUCTION IN PART OR AS A WHOLE WITHOUT THE WRITTEN PERMISSION OF CONTECH IS PROHIBITED.

REVISIONS	
B	
C	
D	
E	

DRAWN BY: T.J.G.
 DESIGN BY: A.JEFFREY
 PLANT:
 SCALE: 1/2" = 1'

CONTECH - CDS TOPSLAB
 8'-0" Ø
 REINFORCEMENT
 DATE: 10/21/25 11"x17" PAGE 1 OF 1