

Job Name: 25-4593 - 823277 Central Ramp Expansion BNA
 Job Location: Nashville, TN
 Contractor: Contech Engineering Solutions

Plant: Beaver Dam, KY
 12/2/2025 11:09:46 AM

Tech: J. Coppage
 PC: T. Sekula



Structure ID: 020-CDS4040-8-C

P5 MH096RSVF

MH RISER Custom Ht

- P7) 24" - CASTING HEIGHT - 0"
- P6) 96" - MH FLAT TOP SPEC. (2 - 24"Ø F&G) - 25"
- P5) 96" - MH RISER Custom Ht - 46"
- P4) 96" - MH RISER - 72"
- P3) 96" - MH RISER Custom Ht - 53"
- P2) 96" - MH RISER - 36"
- P1) 96" - MH SEPARATE BASE-T (114" OD) - 8"
- 1) CVSTENCILING
- 1) This Structure Includes a Cast-in Item - (2 Ea. Castings)
- 1) SECONDARY POUR - Separation Slab*
- 5) 96" - Conseal CS-102 1.00"
- 2) Hole - 42
- 1) Hole - 36

****USE REINFORCEMENT
 INFORMATION PROVIDED
 BY CONTECH****

- | | |
|--|--|
| <ul style="list-style-type: none"> 0 lb 14787 lb 11459 lb 14991 lb 13203 lb 8968 lb 10484 lb 0 lb 0 lb 6669 lb 0 lb 0 lb 0 lb | <p>Structure Notes:</p> <ol style="list-style-type: none"> 1. PER ASTM C-478 SPECS 2. CONCRETE: 7,000 PSI AT 28 DAYS 3. REINFORCEMENT: PER ASTM A615 (GRADE 60) 4. 2 EA. CAST-IN CASTINGS PROVIDED BY OTHERS 5. CASTINGS TO BE CAST INTO FLAT LID FLANGE SIDE UP 6. INVERT 2 OFFSET 6" FROM CENTER <p>SPECIAL NOTES:</p> <ol style="list-style-type: none"> 1. LIFTING HOOKS TO BE INSTALLED ON THE INSIDE OF THE STRUCTURE 2. CONTECH'S LOGO AS WELL AS INLET & OUTLET MUST BE STENCILED ONTO STRUCTURE 3. INTERNALS TO BE INSTALLED BY OTHERS |
|--|--|

Structure Total: 80562 lb

Rim: 551.75' Rim to Invert: 10.37' Slack: 0.44" Sump: 108" Step Position:

Position	Elev	Angle	Ext. (cw)	Pipe	Pipe OD	Connector	Hole	Horz Size	Up (L)	Offset
Invert 1										
Invert 2										
Invert 3										
Invert 4										
Invert 5										
Invert 6										
Invert 7										
Invert 8										

RIGHT-SIDE UP VIEW (int. dimensions)

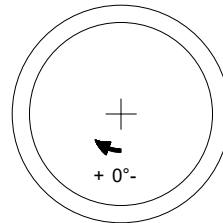
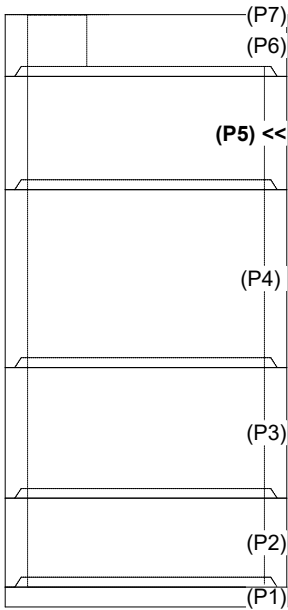

INSIDE WALL DIMENSIONS

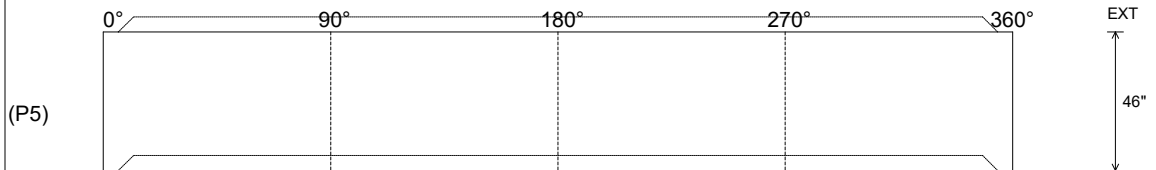

Coating (Int): Coating (Ext):	Seam Up: Tongue Seam Dn: Groove	Wall Thickness: 9" Floor Height: 0"	Height (Int): 46" Height (Ext): 46"	Weight (Net): 11459 lb Volume (Net): 2.93cu.yd
----------------------------------	------------------------------------	--	--	---

25-4593 RISER REINFORCEMENT 020-CDS4040-8-C

DESIGN NOTE:

AIRCRAFT LOADING - 80 KIP WHEEL LOAD - 17.19"x12.68" TIRE FOOTPRINT
 WATER TABLE AT FINISHED GRADE
 DESIGN CONFORMS TO AASHTO LRFD
 CONCRETE 28 DAY COMPRESSIVE STRENGTH - 7000 PSI
 REINFORCEMENT STEEL - 60,000 PSI
 REBAR MIN SPLICE LENGTHS: #3-17" #4-22" #5-28" #6-33"
 REBAR MIN BEND DIAMETERS: #3-2.25" #4-3" #5-3.75" #6-4.5"
 PLACE 4-#4 BAR DIAGONAL AROUND OPENING(S)

823277-20

REINFORCING STEEL SCHEDULE

MARK	NO.	LENGTH	TYPE	BENDING DIAGRAM O.D.
6A	24	8'-5" MAX	STR.	
4B	18	9'-2" MAX	STR.	

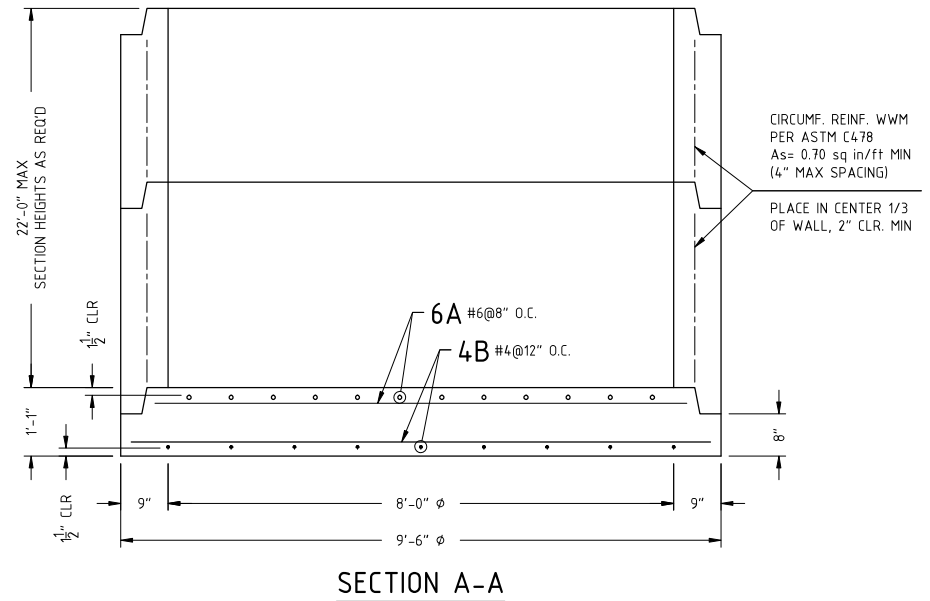
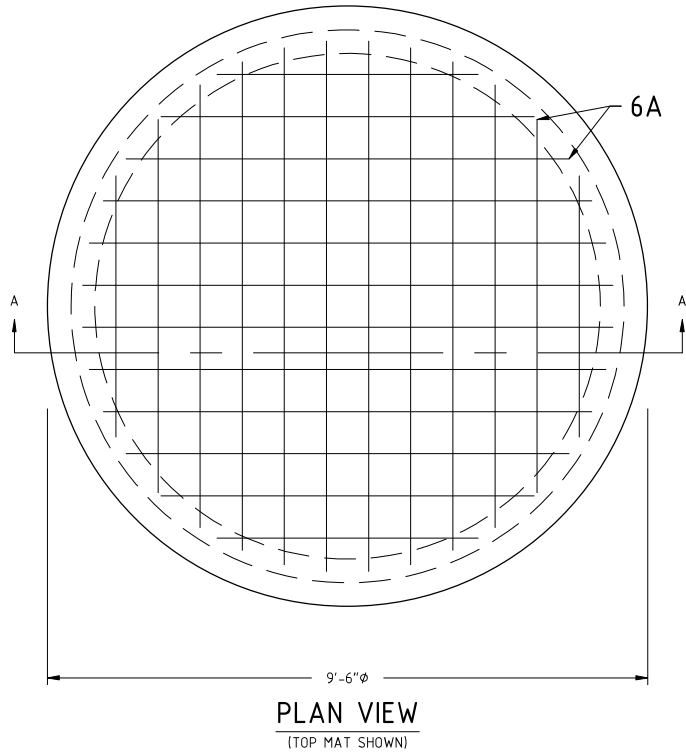

PROPRIETARY AND CONFIDENTIAL:
 THE INFORMATION CONTAINED IN THIS
 DOCUMENT IS THE SOLE PROPERTY OF
 CONTECH. ANY REPRODUCTION IN PART
 OR AS A WHOLE WITHOUT THE WRITTEN
 PERMISSION OF CONTECH IS PROHIBITED.

REVISIONS	
B	
C	
D	
E	

DRAWN BY: T.J.G
 DESIGN BY: A.JEFFREY
 PLANT:
 SCALE: 1/2" = 1'

CONTECH - CDS BASESLAB
 8'-0"φ
 REINFORCEMENT

DATE: 10/21/25 11"x17" PAGE 1 OF 1