

Job Name: 25-4593 - 823277 Central Ramp Expansion BNA
 Job Location: Nashville, TN
 Contractor: Contech Engineering Solutions

Plant: Beaver Dam, KY
 12/4/2025 1:54:13 PM

Tech: J. Coppage
 PC: T. Sekula



Structure ID: 015-CDS5668-10-C

P1 MH120BS06

MH BASE SLAB

- P7) 24" - CASTING HEIGHT - 0"
- P6) 120" - MH FLAT TOP SPEC. (2 - 24"Ø F&G) - 26"
- P5) 120" - MH RISER Custom Ht - 50"
- P4) 120" - MH RISER - 72"
- P3) 120" - MH RISER - 84"
- P2) 120" - MH RISER - 36"
- P1) 120" - MH BASE SLAB - 6"

- 1) CVSTENCILING
- 1) This Structure Includes a Cast-in Item - (2 Ea. Castings)
- 1) SECONDARY POUR - Separation Slab*
- 5) 120" - Conseal CS-102 1.00" ****USE REINFORCEMENT INFORMATION PROVIDED BY CONTECH****
- 2) Hole - 48

****USE REINFORCEMENT INFORMATION PROVIDED BY CONTECH****

- | | |
|----------|-------------------------|
| 0 lb | Structure Notes: |
| 26247 lb | |
| 18994 lb | |
| 23929 lb | |
| 31909 lb | |
| 13675 lb | |
| 14760 lb | |
| 0 lb | |
1. PER ASTM C-478 SPECS
 2. CONCRETE: 7,000 PSI AT 28 DAYS
 3. REINFORCEMENT: PER ASTM A615 (GRADE 60)
 4. 2 EA. CAST-IN CASTINGS PROVIDED BY OTHERS
 5. CASTINGS TO BE CAST INTO FLAT LID FLANGE SIDE UP
 6. LIFTING HOOKS TO BE INSTALLED ON THE INSIDE OF THE STRUCTURE
 7. CONTECH'S LOGO AS WELL AS INLET AND OUTLET MUST BE STENCILED ONTO STRUCTURE
 8. INTERNALS TO BE INSTALLED BY OTHERS

Structure Total: 139877 lb

Rim: 553.59' Rim to Invert: 10.3' Slack: 0.56" Sump: 144.96" Step Position:

GENERAL NOTES:

1. MANUFACTURED TO ASTM C-478 (LATEST REVISION).
2. CONCRETE 7,000 PSI AT 28 DAYS.
3. REINFORCING: USE REINFORCEMENT INFORMATION PROVIDED BY CONTECH. (GRADE 60KSI).

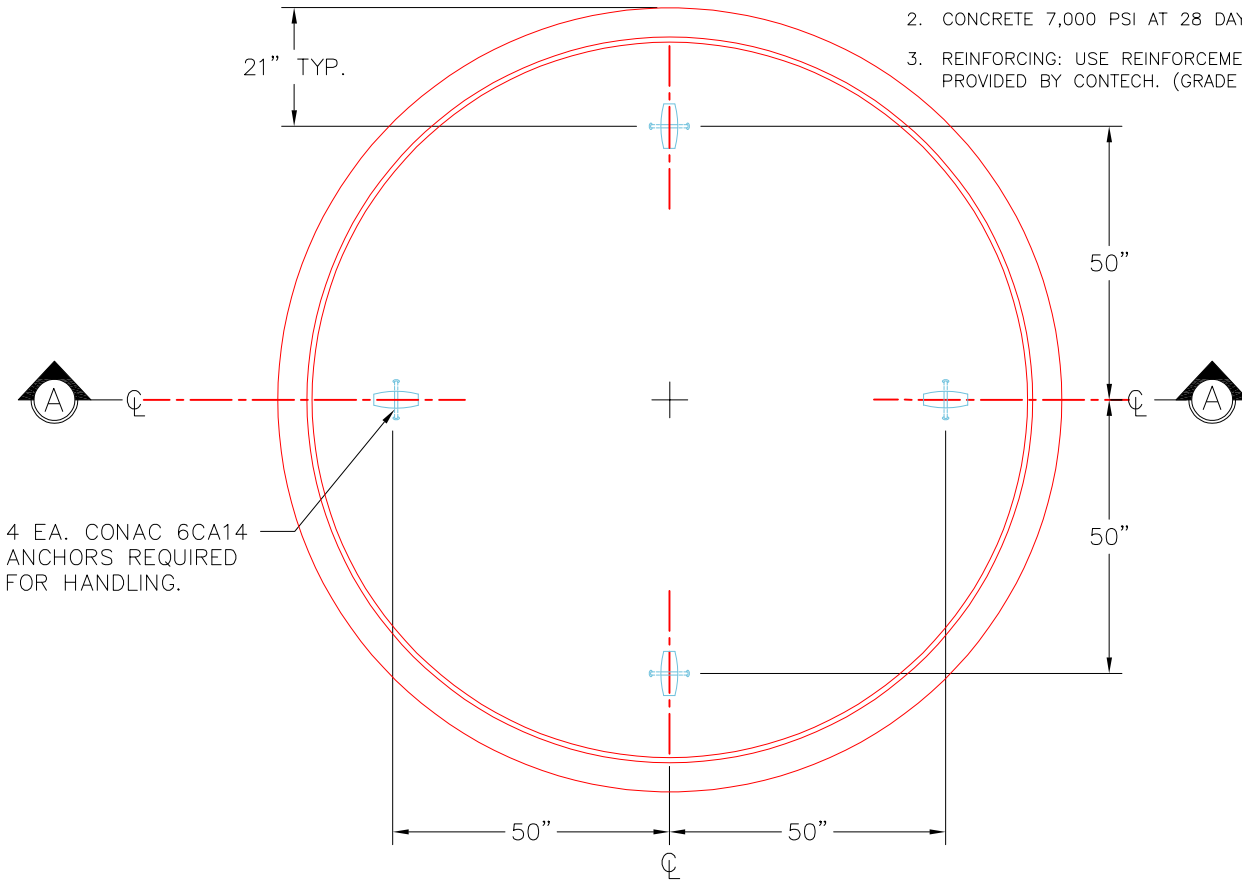

PLAN VIEW

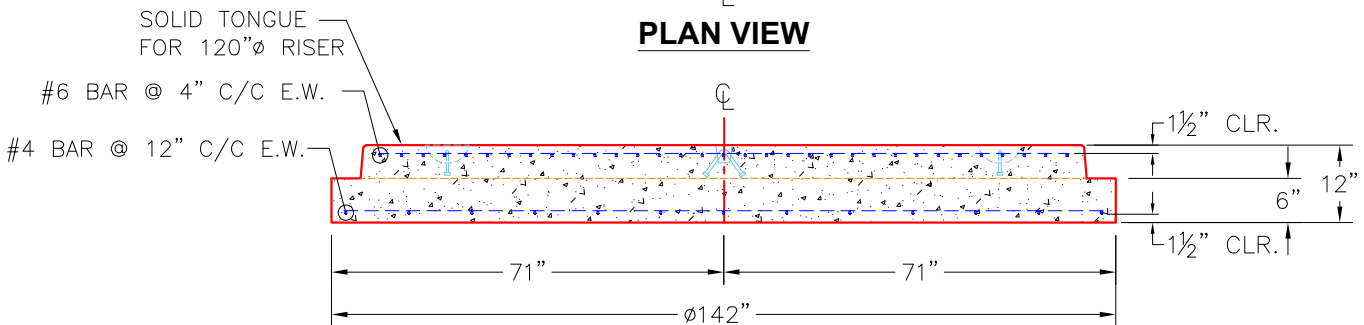

SECTION A-A

Coating (Int): Coating (Ext):	Seam Up: Tongue Seam Dn: n/a	Wall Thickness: 11" Floor Height: 6"	Height (Int): 0" Height (Ext): 0"	Weight (Net): 14760 lb Volume (Net): 2.04cu.yd
----------------------------------	---------------------------------	---	--------------------------------------	---

25-4593 BASE SLAB REINFORCEMENT 015-CDS5668-10-C

DESIGN NOTE:

AIRCRAFT LOADING - 80 KIP WHEEL LOAD - 17.19"x12.68" TIRE FOOTPRINT
 WATER TABLE AT FINISHED GRADE
 DESIGN CONFORMS TO AASHTO LRFD
 CONCRETE 28 DAY COMPRESSIVE STRENGTH - 7000 PSI
 REINFORCEMENT STEEL - 60,000 PSI
 REBAR MIN SPLICE LENGTHS: #3-17" #4-22" #5-28" #6-33"
 REBAR MIN BEND DIAMETERS: #3-2.25" #4-3" #5-3.75" #6-4.5"
 PLACE 4-#4 BAR DIAGONAL AROUND OPENING(S)

823277-15

REINFORCING STEEL SCHEDULE

MARK	NO.	LENGTH	TYPE	BENDING DIAGRAM O.D.
6A	42	10'-7" MAX	STR.	
4B	24	11'-6" MAX	STR.	

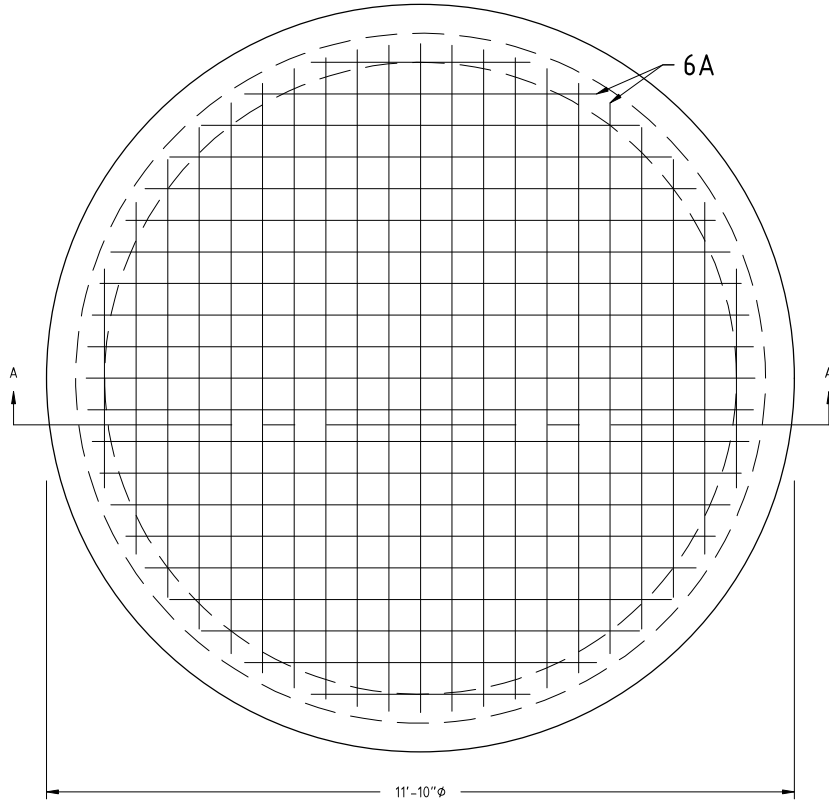

PLAN VIEW
(TOP MAT SHOWN)

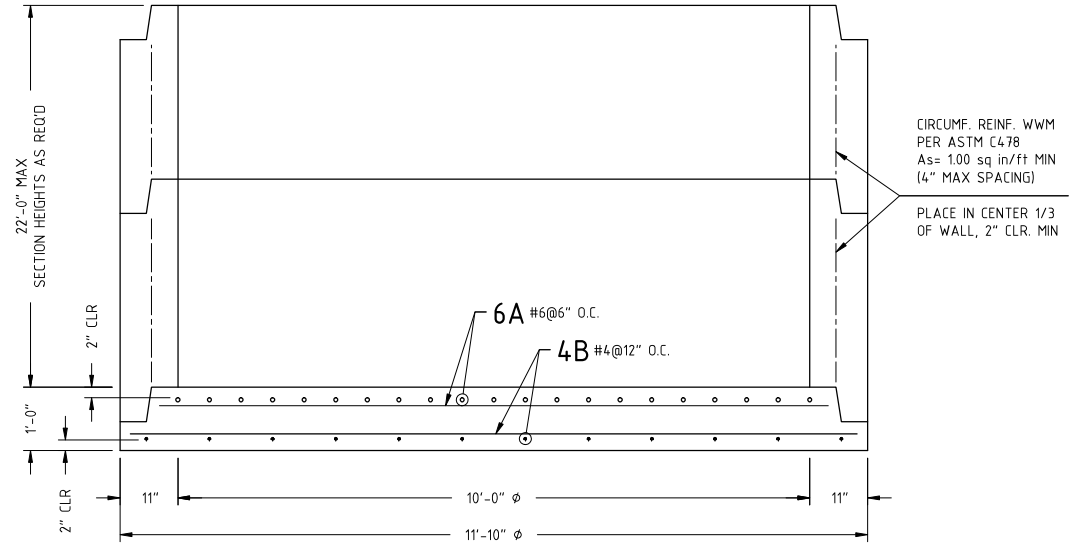

SECTION A-A



PROPRIETARY AND CONFIDENTIAL:
 THE INFORMATION CONTAINED IN THIS DOCUMENT IS THE SOLE PROPERTY OF CONTECH. ANY REPRODUCTION IN PART OR AS A WHOLE WITHOUT THE WRITTEN PERMISSION OF CONTECH IS PROHIBITED.

REVISIONS	
B	
C	
D	
E	

DRAWN BY: T.J.G.
 DESIGN BY: A.JEFFREY
 PLANT:
 SCALE: 1/2" = 1'

CONTECH - CDS - BASESLAB
 10'-0" Ø
 REINFORCEMENT

DATE: 10/14/25 11"x17" PAGE 1 OF 1