

Job Name: 25-4583 - Housing Authority
 Job Location: Morgantown, KY 42261
 Contractor: Dirt Movers

Plant: 100

Tech: J. Horsley - A

12/30/2025 10:00:03 AM

PC: Trevor Lewis



Structure ID: 1C (4)

P2 MH048RS72

MH RISER T/G

- P4) 24" x 30" - CASTING HEIGHT - 3.50"
- P3) 48" - MH FLAT TOP w/24"x30" Hole F/G - 12"
- P2) 48" - MH RISER T/G - 72"
- P1) 48" - MH BASE T/n - 48"
- 1) CASTING - HOE 275-A F/G
- 2) 48" - Conseal CS-102 1.00"
- 1) 24" x 30" - Conseal CS-102 1.00"
- 1) Hole - 28
- 1) Hole - 18
- 10) MH Step ML-10-TDS-NCR - 10"

0 lb
 1935 lb
 4921 lb
 4411 lb
 345 lb
 0 lb
 0 lb
 0 lb
 0 lb
 0 lb
 0 lb
 Structure Total: 11612 lb

- Structure Notes:**
1. HOE 275-A FRAME & GRATE PROVIDED BY ICAST
 2. PER ASTM C-478 SPECIFICATIONS
 3. CONCRETE: 4,000 PSI AT 28 DAYS
 4. REINFORCEMENT: PER ASTM A615
 5. STEPS AT 90 DEGREES

Rim: 501.28' Rim to Invert: 11.28' Slack: 0.36" Sump: 0.5" Step Position: 0°

| Position | Elev | Angle | Ext. (cw) | Pipe | Pipe OD | Connector | Hole | Horz Size | Up (⌊) | Offset |
|----------|---------|-------|-----------|---------|---------|-----------|------|-----------|--------|--------|
| Invert 1 | | | | | | | | | | |
| Invert 2 | 495.18' | 159° | 80.477" | 15" CMP | 16" | Hole 18 | 18" | 18.451" | 9.91" | 0" |
| Invert 3 | | | | | | | | | | |
| Invert 4 | | | | | | | | | | |
| Invert 5 | | | | | | | | | | |
| Invert 6 | | | | | | | | | | |
| Invert 7 | | | | | | | | | | |
| Invert 8 | | | | | | | | | | |

RIGHT-SIDE UP VIEW (int. dimensions)

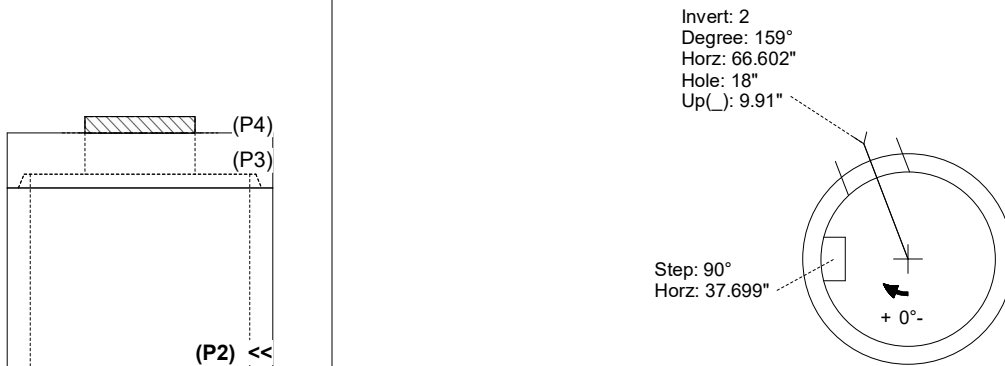

INSIDE WALL DIMENSIONS

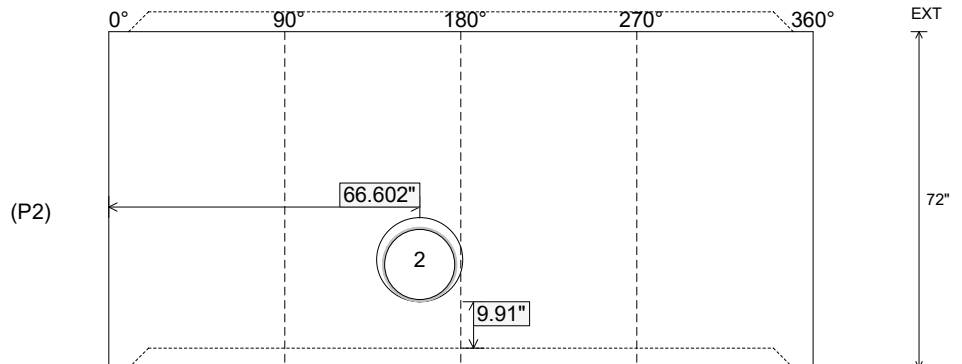

Coating (Int):
 Coating (Ext):

Seam Up: Tongue
 Seam Dn: Groove

Wall Thickness: 5"
 Floor Height: 0"

Height (Int): 72"
 Height (Ext): 72"

Weight (Net): 4921 lb
 Volume (Net): 1.26cu.yd