

Job Name: 25-4583 - Housing Authority  
 Job Location: Morgantown, KY 42261  
 Contractor: Dirt Movers

Plant: 100

Tech: J. Horsley - A

12/30/2025 9:59:44 AM

PC: Trevor Lewis



**Structure ID: 1C (4)**

**P1 MH048BA48**

**MH BASE T/n**

- P4) 24" x 30" - CASTING HEIGHT - 3.50"
- P3) 48" - MH FLAT TOP w/24"x30" Hole F/G - 12"
- P2) 48" - MH RISER T/G - 72"
- P1) 48" - MH BASE T/n - 48"
- 1) CASTING - HOE 275-A F/G
- 2) 48" - Conseal CS-102 1.00"
- 1) 24" x 30" - Conseal CS-102 1.00"
- 1) Hole - 28
- 1) Hole - 18
- 10) MH Step ML-10-TDS-NCR - 10"

0 lb  
 1935 lb  
 4921 lb  
 4411 lb  
 345 lb  
 0 lb  
 0 lb  
 0 lb  
 0 lb  
 0 lb  
 0 lb  
 11612 lb

- Structure Notes:**
1. HOE 275-A FRAME & GRATE PROVIDED BY ICAST
  2. PER ASTM C-478 SPECIFICATIONS
  3. CONCRETE: 4,000 PSI AT 28 DAYS
  4. REINFORCEMENT: PER ASTM A615
  5. STEPS AT 90 DEGREES

Structure Total:

Rim: 501.28' Rim to Invert: 11.28' Slack: 0.36" Sump: 0.5" Step Position: 0°

Position	Elev	Angle	Ext. (cw)	Pipe	Pipe OD	Connector	Hole	Horz Size	Up ( )	Offset
Invert 1	490'	0°	0"	24" CMP	25"	Hole 28	28"	29.896"	0"	0"
Invert 2										
Invert 3										
Invert 4										
Invert 5										
Invert 6										
Invert 7										
Invert 8										

RIGHT-SIDE UP VIEW (int. dimensions)

UPSIDE-DOWN VIEW (int. dimensions)

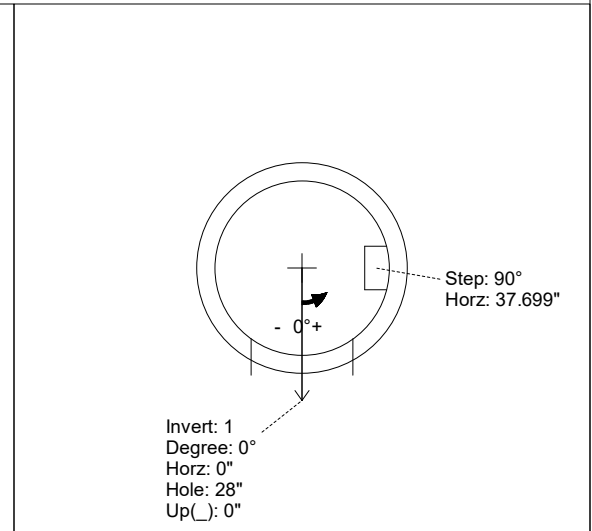
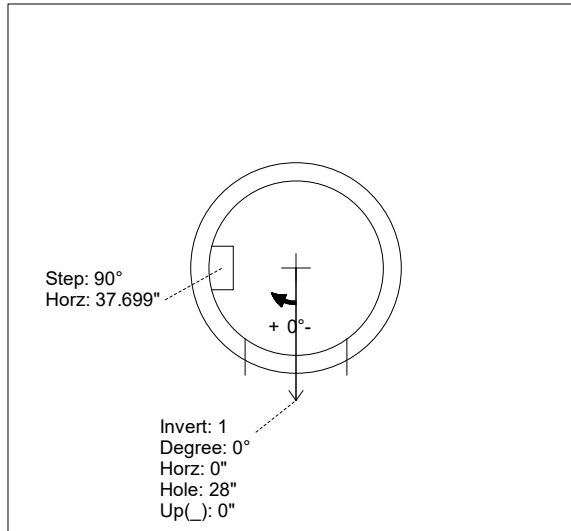
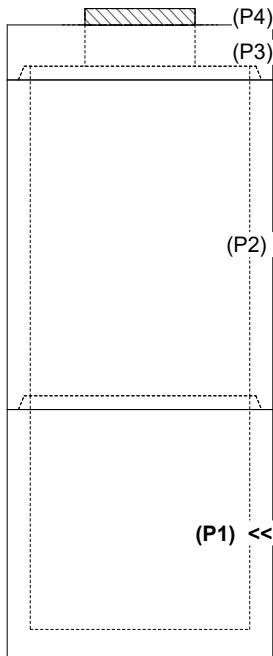

INSIDE WALL DIMENSIONS

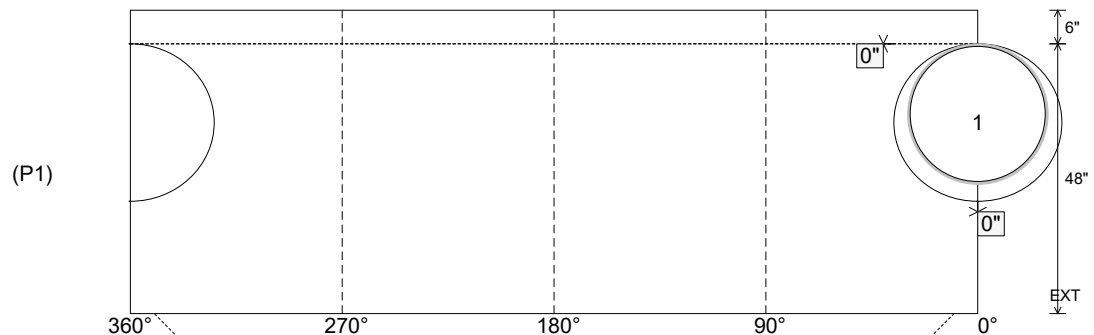

Coating (Int):  
 Coating (Ext):

Seam Up: Tongue  
 Seam Dn: n/a

Wall Thickness: 5"  
 Floor Height: 6"

Height (Int): 48"  
 Height (Ext): 54"

Weight (Net): 4411 lb  
 Volume (Net): 1.13cu.yd