

Job Name: 25-4583 - Housing Authority
Job Location: Morgantown, KY 42261
Contractor: Dirt Movers

PC: Trevor Lewis
 TECH: J. Horsley - A
 Plant: 100



Structure ID: **1B (3)**

Spec: Storm
 Type: STM.MH
 Size: 48"

Rim: 470.44'
 Invert: 460'
 Rim to Invert: 10.44'

Sump: 0.5"
 Floor (Top): 459.958'
 Floor Height: 6"

Floor (Bot): 459.458'
 Overall Height: 10.792'
 Slack: 2.28"

Structure Notes:

- PLAN LABEL: D.I. #1.B
 1. HOE 275-A FRAME & GRATE PROVIDED BY ICAST
 2. PER ASTM C-478 SPECIFICATIONS
 3. CONCRETE: 4,000 PSI AT 28 DAYS
 4. REINFORCEMENT:
 - FLAT LID: #4 BAR @ 10" C.C. E.W. (GRADE 60)
 - BASE & RISER: PER ASTM A615
 5. STEPS AT 90 DEGREES

STRUCTURE SUMMARY:

P4) 24" x 30" - CASTING HEIGHT - 3.50"	0 lb
P3) 48" - MH FLAT TOP w/24"x30" Hole F/G - 12"	1935 lb
P2) 48" - MH RISER T/G - 48"	3353 lb
P1) 48" - MH BASE T/n - 60"	4976 lb
1) CASTING - HOE 275-A F/G	345 lb
2) 48" - Conseal CS-102 1.00"	0 lb
1) 24" x 30" - Conseal CS-102 1.00"	0 lb
2) Hole - 28	0 lb
9) MH Step ML-10-TDS-NCR - 10"	0 lb

Structure Total:	10610 lb

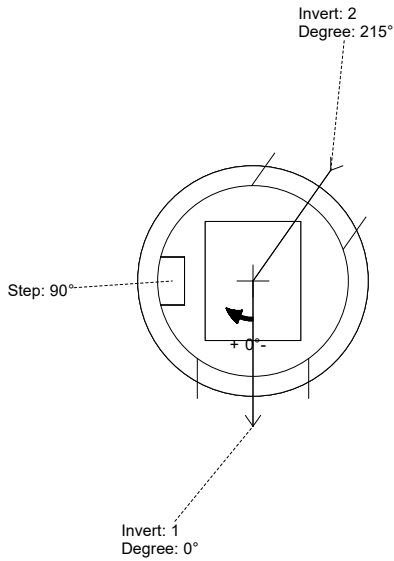

Position	Elev	Angle	Pipe	Pipe OD	Hole	Connector	Up (L)	Ref
Rim	470.44'							
Reducer								
Invert 1	460'	0°	24" CMP	25"	28"	Hole 28	0"	P1
Invert 2	460'	215°	24" CMP	25"	28"	Hole 28	0"	P1
Invert 3								
Invert 4								
Invert 5								
Invert 6								
Invert 7								
Invert 8								

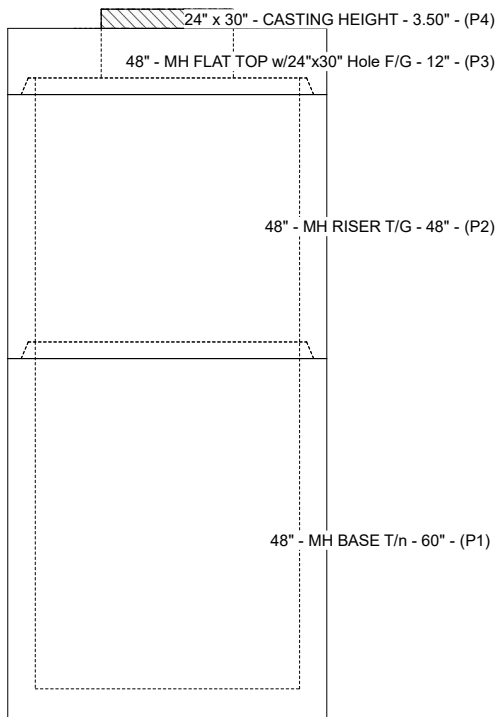

Cast (Int. Dim.) - Interior Dimensions

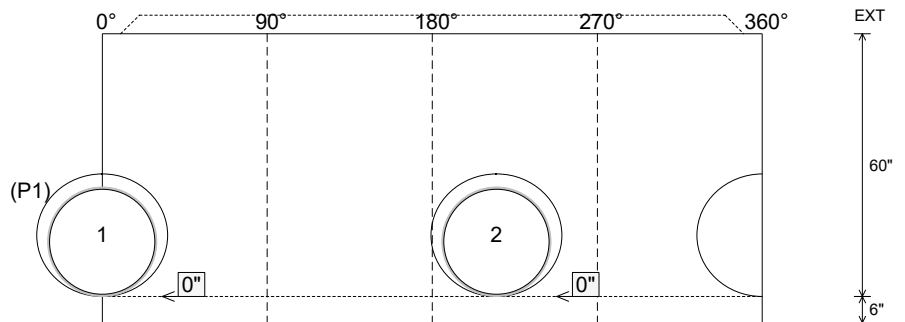

Submittal Drawing
 12/30/2025 9:52:54 AM

SUBMITTAL
 APPROVED BY: