

25-4537 - 863626 Project Tahoe

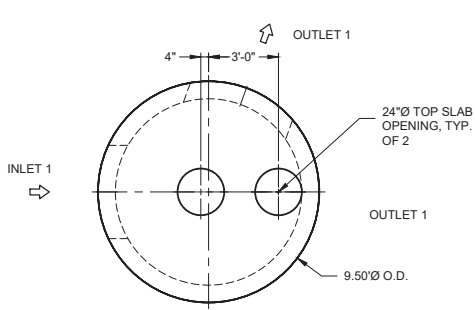

PLAN VIEW
INTERNALS NOT SHOWN

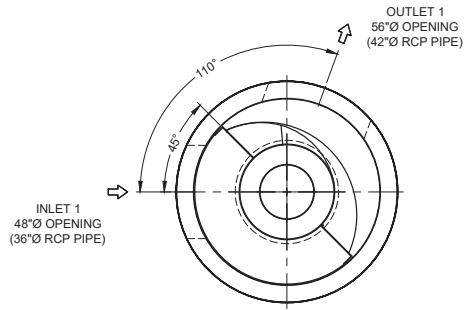

PLAN VIEW FOR PIPE ORIENTATION
TOP SLAB NOT SHOWN

90-CDS4045-8-C iCast to Fully Pre-Assemble Internal Materials Prior to Shipment

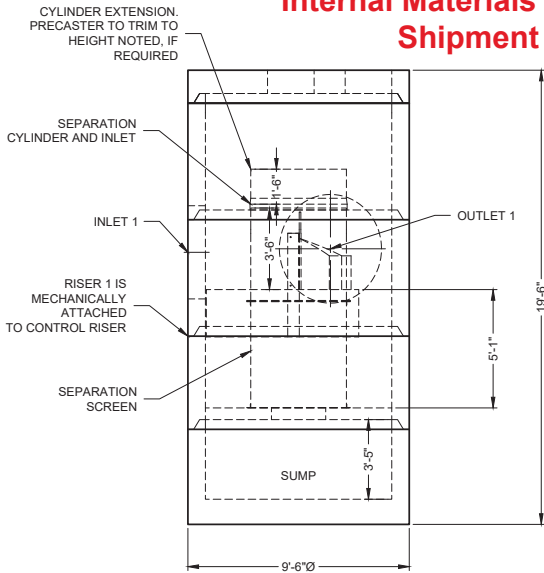

ELEVATION VIEW

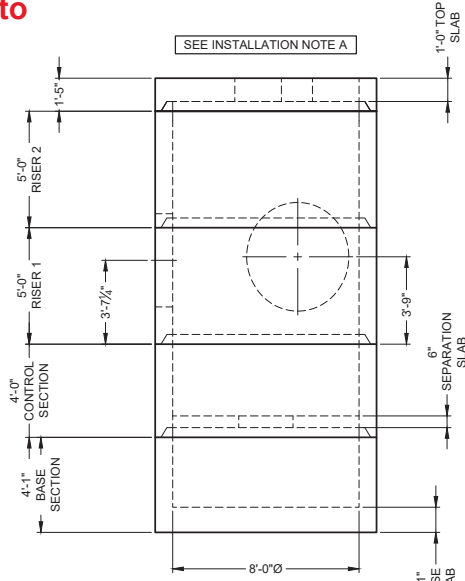

PRECAST COMPONENTS
INTERNALS NOT SHOWN

MATERIAL LIST

COUNT	DESCRIPTION	PART NUMBER	PROVIDED BY	INSTALLED BY
1	4045-8 CONCENTRIC FIBERGLASS INSERT	325-000796	CONTECH	PRECASTER
1	4045, 2400 micron, 4.1' O.D. x 4.58' SCREEN, GREEN FLANGE UP	335-000390	CONTECH	PRECASTER
1	20, 30, 40 SERIES HARDWARE KIT	325-003921	CONTECH	PRECASTER
1	40 SERIES, 1.5 FT. TALL CYLINDER EXTENSION	325-002788	CONTECH	CONTRACTOR
1	SEALANT FOR JOINTS		PRECASTER	CONTRACTOR
2	24"Ø X 4" FRAME AND COVER, EJ #1600389, OR EQUIV.	325-000350	CONTECH	CONTRACTOR

GENERAL NOTES

- DESIGN LOADING - AASHTO HS-20
- ALL PRECAST CONCRETE MANUFACTURED PARTS SHALL CONFORM TO ASTM C-478, WITH MINIMUM CONCRETE STRENGTH OF 4000 PSI AT 28 DAYS
- JOINT SEALANT SHALL CONFORM TO ASTM C-990 OR ASTM C-443
- GROUND WATER ASSUMED AT OUTLET INVERT
- MANUFACTURING TOLERANCE = +/- 1/2-INCH
- SOME HIDDEN LINES MAY BE OMITTED FOR CLARITY

INSTALLATION NOTES

- PRECASTER TO SHIP FRAME AND COVER WITH STRUCTURE
- REFER TO CONTECH ASSEMBLY INSTRUCTIONS FOR ADDITIONAL INFORMATION
- FOR PROPER SCREEN ORIENTATION, FLANGE IS COLOR CODED, INSTALL GREEN FLANGE UP
- IF REQUIRED, PVC HYDRAULIC SHEAR PLATE IS PLACED ON SEPARATION SLAB AT BOTTOM OF SCREEN CYLINDER
- PRECASTER TO INSTALL INTERNAL COMPONENTS PRIOR TO SHIPPING UNLESS INSTRUCTED OTHERWISE BY CONTECH
- PIPE OPENINGS SHALL BE STENCILED "INLET" OR "OUTLET" AS APPROPRIATE
- APPLYING ALIGNMENT MARKS ON ALL PIECES OF MULTIPLE ASSEMBLIES IS HIGHLY ENCOURAGED
- IF STRUCTURE IS DELIVERED IN MULTIPLE SECTIONS, EACH PIECE SHALL BE LABELED WITH THE CONTECH PROJECT NUMBER, SEQUENCE NUMBER AND SITE DESIGNATION

SITE INFORMATION

RIM ELEV. = 881.4+/-
 TOP OF STRUCTURE ELEV. = 880.82
 INLET PIPE 1 INVERT ELEV. = 871.50
 OUTLET PIPE 1 DIAMETER AND MATERIAL = 36" RCP
 OUTLET PIPE 1 INVERT ELEV. = 871.40
 OUTLET PIPE 1 DIAMETER AND MATERIAL = 42" RCP
 OUTSIDE BOTTOM OF STRUCTURE ELEV. = 861.32

STRUCTURE WEIGHT

APPROXIMATE HEAVIEST PICK = 22500 LBS.
 STRUCTURE IS DELIVERED IN 4 PIECES

 TOP SLAB = 11000 LBS.
 RISER 2 = 14500 LBS.
 RISER 1 = MECHANICALLY ATTACHED TO CONTROL SECTION
 CONTROL SECTION = 32500 LBS.
 BASE SECTION = 22500 LBS.

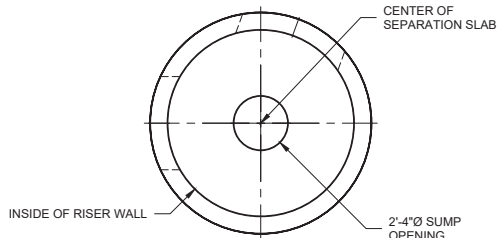

SEPARATION SLAB

CONTECH
FABRICATION
DRAWING

ICAST
5888 / 757440
LAYOUT 1A
37.91 TS

This design and information shown on this drawing is the property of CONTECH Engineering Solutions LLC. It is to be used for the project and site designated on this drawing. No part thereof may be used, copied, or reproduced in any form without the written consent of CONTECH. It shall be the responsibility of the contractor to verify the accuracy of the information shown on this drawing for use on the project. If discrepancies between the supplied information and the information shown on this drawing are discovered, the contractor shall be responsible for resolving the discrepancies. CONTECH is not responsible for design based on, or use of, this drawing. CONTECH is not responsible for design based on, or use of, this drawing. CONTECH is not responsible for design based on, or use of, this drawing.

REVISION DESCRIPTION	DATE	MARK	BY

CDS4045-8-C - 863626-90
 PROJECT TAHOE
 BROWNSBURG, IN
 SITE DESIGNATION: WQ-230

CONTECH
 ENGINEERING SOLUTIONS LLC
 www.contech.com
 8000 Center Pointe Dr., Suite 400, Muncie, Indiana, IN 47306
 800-338-1132 513-5487-7000 513-5485-5933 FAX
 CONTECH ENGINEERING SOLUTIONS LLC © 2025

6ds
 6ds ENGINEERING SOLUTIONS LLC © 2025

DATE:	10/30/2025
DESIGNED:	MDB
DRAWN:	MDB
CHECKED:	MSB
APPROVED:	MDB
PROJECT No.:	863626
SEQUENCE No.:	90
SHEET:	1 OF 2

I:\PROJECTS\25-4537\CONTECH\PROJECT\ACTIVITY\06/08/2025\863626-90-CDS DRAWINGS\863626-90-CDS-4045-8-C-CON FAB DWG 11/02/2025 8:49 AM

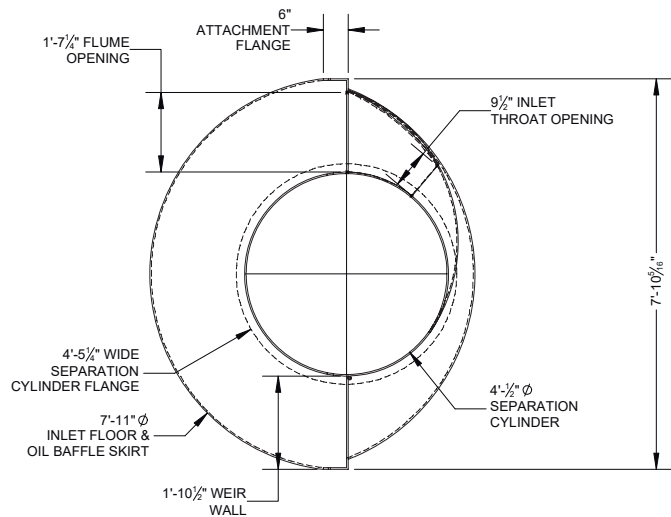

PLAN VIEW

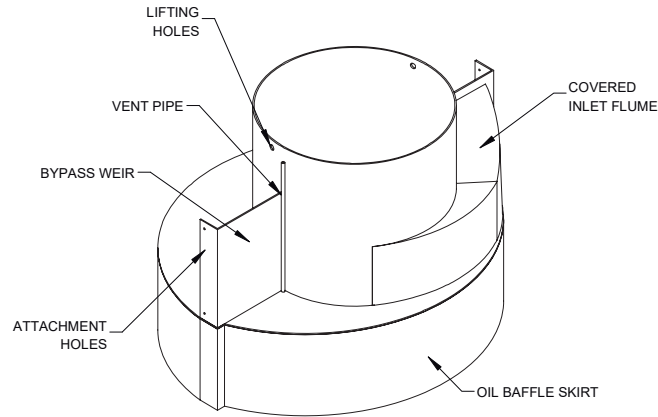

ASSEMBLY TOP VIEW

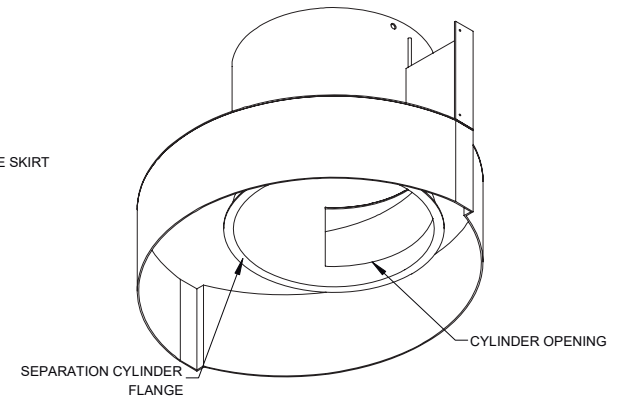

ASSEMBLY BOTTOM VIEW

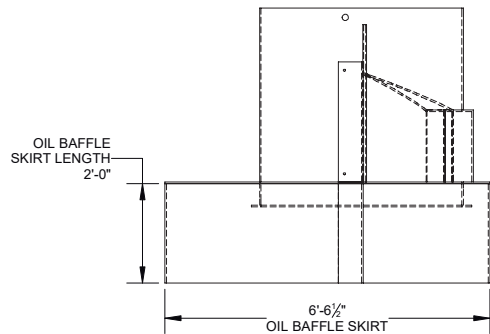

ELEVATION VIEW

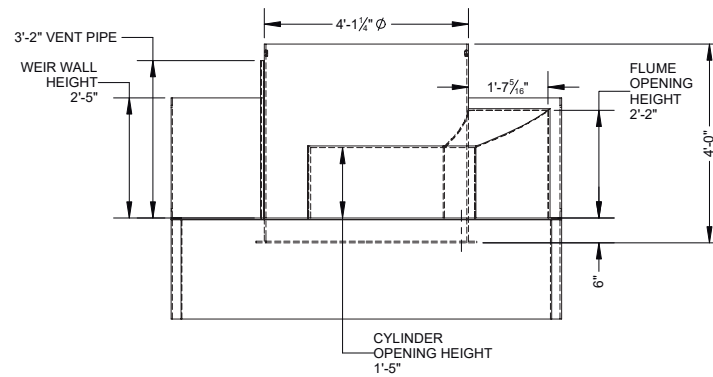

SIDE VIEW

NOTES:
 1. SEE CDS UNIT ASSEMBLY AND INSTALLATION GUIDE FOR ADDITIONAL INFORMATION

The design and information shown on this drawing is provided as a service to the project owner, engineer and contractor by Contech Engineered Solutions LLC, or one of its affiliated companies ("Contech"). Neither this drawing, nor any part thereof, may be used, reproduced or modified in any manner without the prior written consent of Contech. Failure to comply with the above shall be deemed to constitute an express disclaimer of any liability or responsibility for such use.

If discrepancies between the supplied information upon which the drawing is based and actual field conditions are encountered as site work progresses, these discrepancies must be reported to Contech immediately for re-evaluation of the design. Contech accepts no liability for designs based on missing, incomplete or inaccurate information supplied by others.



THIS PRODUCT MAY BE PROTECTED BY ONE OR MORE OF THE FOLLOWING U.S. PATENTS: 8718,949; 8,641,725; 8,611,046; 8,611,048; 8,611,049; 8,611,050; 8,611,051; 8,611,052; 8,611,053; 8,611,054; 8,611,055; 8,611,056; 8,611,057; 8,611,058; 8,611,059; 8,611,060; 8,611,061; 8,611,062; 8,611,063; 8,611,064; 8,611,065; 8,611,066; 8,611,067; 8,611,068; 8,611,069; 8,611,070; 8,611,071; 8,611,072; 8,611,073; 8,611,074; 8,611,075; 8,611,076; 8,611,077; 8,611,078; 8,611,079; 8,611,080; 8,611,081; 8,611,082; 8,611,083; 8,611,084; 8,611,085; 8,611,086; 8,611,087; 8,611,088; 8,611,089; 8,611,090; 8,611,091; 8,611,092; 8,611,093; 8,611,094; 8,611,095; 8,611,096; 8,611,097; 8,611,098; 8,611,099; 8,611,100; 8,611,101; 8,611,102; 8,611,103; 8,611,104; 8,611,105; 8,611,106; 8,611,107; 8,611,108; 8,611,109; 8,611,110; 8,611,111; 8,611,112; 8,611,113; 8,611,114; 8,611,115; 8,611,116; 8,611,117; 8,611,118; 8,611,119; 8,611,120; 8,611,121; 8,611,122; 8,611,123; 8,611,124; 8,611,125; 8,611,126; 8,611,127; 8,611,128; 8,611,129; 8,611,130; 8,611,131; 8,611,132; 8,611,133; 8,611,134; 8,611,135; 8,611,136; 8,611,137; 8,611,138; 8,611,139; 8,611,140; 8,611,141; 8,611,142; 8,611,143; 8,611,144; 8,611,145; 8,611,146; 8,611,147; 8,611,148; 8,611,149; 8,611,150; 8,611,151; 8,611,152; 8,611,153; 8,611,154; 8,611,155; 8,611,156; 8,611,157; 8,611,158; 8,611,159; 8,611,160; 8,611,161; 8,611,162; 8,611,163; 8,611,164; 8,611,165; 8,611,166; 8,611,167; 8,611,168; 8,611,169; 8,611,170; 8,611,171; 8,611,172; 8,611,173; 8,611,174; 8,611,175; 8,611,176; 8,611,177; 8,611,178; 8,611,179; 8,611,180; 8,611,181; 8,611,182; 8,611,183; 8,611,184; 8,611,185; 8,611,186; 8,611,187; 8,611,188; 8,611,189; 8,611,190; 8,611,191; 8,611,192; 8,611,193; 8,611,194; 8,611,195; 8,611,196; 8,611,197; 8,611,198; 8,611,199; 8,611,200; 8,611,201; 8,611,202; 8,611,203; 8,611,204; 8,611,205; 8,611,206; 8,611,207; 8,611,208; 8,611,209; 8,611,210; 8,611,211; 8,611,212; 8,611,213; 8,611,214; 8,611,215; 8,611,216; 8,611,217; 8,611,218; 8,611,219; 8,611,220; 8,611,221; 8,611,222; 8,611,223; 8,611,224; 8,611,225; 8,611,226; 8,611,227; 8,611,228; 8,611,229; 8,611,230; 8,611,231; 8,611,232; 8,611,233; 8,611,234; 8,611,235; 8,611,236; 8,611,237; 8,611,238; 8,611,239; 8,611,240; 8,611,241; 8,611,242; 8,611,243; 8,611,244; 8,611,245; 8,611,246; 8,611,247; 8,611,248; 8,611,249; 8,611,250; 8,611,251; 8,611,252; 8,611,253; 8,611,254; 8,611,255; 8,611,256; 8,611,257; 8,611,258; 8,611,259; 8,611,260; 8,611,261; 8,611,262; 8,611,263; 8,611,264; 8,611,265; 8,611,266; 8,611,267; 8,611,268; 8,611,269; 8,611,270; 8,611,271; 8,611,272; 8,611,273; 8,611,274; 8,611,275; 8,611,276; 8,611,277; 8,611,278; 8,611,279; 8,611,280; 8,611,281; 8,611,282; 8,611,283; 8,611,284; 8,611,285; 8,611,286; 8,611,287; 8,611,288; 8,611,289; 8,611,290; 8,611,291; 8,611,292; 8,611,293; 8,611,294; 8,611,295; 8,611,296; 8,611,297; 8,611,298; 8,611,299; 8,611,300; 8,611,301; 8,611,302; 8,611,303; 8,611,304; 8,611,305; 8,611,306; 8,611,307; 8,611,308; 8,611,309; 8,611,310; 8,611,311; 8,611,312; 8,611,313; 8,611,314; 8,611,315; 8,611,316; 8,611,317; 8,611,318; 8,611,319; 8,611,320; 8,611,321; 8,611,322; 8,611,323; 8,611,324; 8,611,325; 8,611,326; 8,611,327; 8,611,328; 8,611,329; 8,611,330; 8,611,331; 8,611,332; 8,611,333; 8,611,334; 8,611,335; 8,611,336; 8,611,337; 8,611,338; 8,611,339; 8,611,340; 8,611,341; 8,611,342; 8,611,343; 8,611,344; 8,611,345; 8,611,346; 8,611,347; 8,611,348; 8,611,349; 8,611,350; 8,611,351; 8,611,352; 8,611,353; 8,611,354; 8,611,355; 8,611,356; 8,611,357; 8,611,358; 8,611,359; 8,611,360; 8,611,361; 8,611,362; 8,611,363; 8,611,364; 8,611,365; 8,611,366; 8,611,367; 8,611,368; 8,611,369; 8,611,370; 8,611,371; 8,611,372; 8,611,373; 8,611,374; 8,611,375; 8,611,376; 8,611,377; 8,611,378; 8,611,379; 8,611,380; 8,611,381; 8,611,382; 8,611,383; 8,611,384; 8,611,385; 8,611,386; 8,611,387; 8,611,388; 8,611,389; 8,611,390; 8,611,391; 8,611,392; 8,611,393; 8,611,394; 8,611,395; 8,611,396; 8,611,397; 8,611,398; 8,611,399; 8,611,400; 8,611,401; 8,611,402; 8,611,403; 8,611,404; 8,611,405; 8,611,406; 8,611,407; 8,611,408; 8,611,409; 8,611,410; 8,611,411; 8,611,412; 8,611,413; 8,611,414; 8,611,415; 8,611,416; 8,611,417; 8,611,418; 8,611,419; 8,611,420; 8,611,421; 8,611,422; 8,611,423; 8,611,424; 8,611,425; 8,611,426; 8,611,427; 8,611,428; 8,611,429; 8,611,430; 8,611,431; 8,611,432; 8,611,433; 8,611,434; 8,611,435; 8,611,436; 8,611,437; 8,611,438; 8,611,439; 8,611,440; 8,611,441; 8,611,442; 8,611,443; 8,611,444; 8,611,445; 8,611,446; 8,611,447; 8,611,448; 8,611,449; 8,611,450; 8,611,451; 8,611,452; 8,611,453; 8,611,454; 8,611,455; 8,611,456; 8,611,457; 8,611,458; 8,611,459; 8,611,460; 8,611,461; 8,611,462; 8,611,463; 8,611,464; 8,611,465; 8,611,466; 8,611,467; 8,611,468; 8,611,469; 8,611,470; 8,611,471; 8,611,472; 8,611,473; 8,611,474; 8,611,475; 8,611,476; 8,611,477; 8,611,478; 8,611,479; 8,611,480; 8,611,481; 8,611,482; 8,611,483; 8,611,484; 8,611,485; 8,611,486; 8,611,487; 8,611,488; 8,611,489; 8,611,490; 8,611,491; 8,611,492; 8,611,493; 8,611,494; 8,611,495; 8,611,496; 8,611,497; 8,611,498; 8,611,499; 8,611,500; 8,611,501; 8,611,502; 8,611,503; 8,611,504; 8,611,505; 8,611,506; 8,611,507; 8,611,508; 8,611,509; 8,611,510; 8,611,511; 8,611,512; 8,611,513; 8,611,514; 8,611,515; 8,611,516; 8,611,517; 8,611,518; 8,611,519; 8,611,520; 8,611,521; 8,611,522; 8,611,523; 8,611,524; 8,611,525; 8,611,526; 8,611,527; 8,611,528; 8,611,529; 8,611,530; 8,611,531; 8,611,532; 8,611,533; 8,611,534; 8,611,535; 8,611,536; 8,611,537; 8,611,538; 8,611,539; 8,611,540; 8,611,541; 8,611,542; 8,611,543; 8,611,544; 8,611,545; 8,611,546; 8,611,547; 8,611,548; 8,611,549; 8,611,550; 8,611,551; 8,611,552; 8,611,553; 8,611,554; 8,611,555; 8,611,556; 8,611,557; 8,611,558; 8,611,559; 8,611,560; 8,611,561; 8,611,562; 8,611,563; 8,611,564; 8,611,565; 8,611,566; 8,611,567; 8,611,568; 8,611,569; 8,611,570; 8,611,571; 8,611,572; 8,611,573; 8,611,574; 8,611,575; 8,611,576; 8,611,577; 8,611,578; 8,611,579; 8,611,580; 8,611,581; 8,611,582; 8,611,583; 8,611,584; 8,611,585; 8,611,586; 8,611,587; 8,611,588; 8,611,589; 8,611,590; 8,611,591; 8,611,592; 8,611,593; 8,611,594; 8,611,595; 8,611,596; 8,611,597; 8,611,598; 8,611,599; 8,611,600; 8,611,601; 8,611,602; 8,611,603; 8,611,604; 8,611,605; 8,611,606; 8,611,607; 8,611,608; 8,611,609; 8,611,610; 8,611,611; 8,611,612; 8,611,613; 8,611,614; 8,611,615; 8,611,616; 8,611,617; 8,611,618; 8,611,619; 8,611,620; 8,611,621; 8,611,622; 8,611,623; 8,611,624; 8,611,625; 8,611,626; 8,611,627; 8,611,628; 8,611,629; 8,611,630; 8,611,631; 8,611,632; 8,611,633; 8,611,634; 8,611,635; 8,611,636; 8,611,637; 8,611,638; 8,611,639; 8,611,640; 8,611,641; 8,611,642; 8,611,643; 8,611,644; 8,611,645; 8,611,646; 8,611,647; 8,611,648; 8,611,649; 8,611,650; 8,611,651; 8,611,652; 8,611,653; 8,611,654; 8,611,655; 8,611,656; 8,611,657; 8,611,658; 8,611,659; 8,611,660; 8,611,661; 8,611,662; 8,611,663; 8,611,664; 8,611,665; 8,611,666; 8,611,667; 8,611,668; 8,611,669; 8,611,670; 8,611,671; 8,611,672; 8,611,673; 8,611,674; 8,611,675; 8,611,676; 8,611,677; 8,611,678; 8,611,679; 8,611,680; 8,611,681; 8,611,682; 8,611,683; 8,611,684; 8,611,685; 8,611,686; 8,611,687; 8,611,688; 8,611,689; 8,611,690; 8,611,691; 8,611,692; 8,611,693; 8,611,694; 8,611,695; 8,611,696; 8,611,697; 8,611,698; 8,611,699; 8,611,700; 8,611,701; 8,611,702; 8,611,703; 8,611,704; 8,611,705; 8,611,706; 8,611,707; 8,611,708; 8,611,709; 8,611,710; 8,611,711; 8,611,712; 8,611,713; 8,611,714; 8,611,715; 8,611,716; 8,611,717; 8,611,718; 8,611,719; 8,611,720; 8,611,721; 8,611,722; 8,611,723; 8,611,724; 8,611,725; 8,611,726; 8,611,727; 8,611,728; 8,611,729; 8,611,730; 8,611,731; 8,611,732; 8,611,733; 8,611,734; 8,611,735; 8,611,736; 8,611,737; 8,611,738; 8,611,739; 8,611,740; 8,611,741; 8,611,742; 8,611,743; 8,611,744; 8,611,745; 8,611,746; 8,611,747; 8,611,748; 8,611,749; 8,611,750; 8,611,751; 8,611,752; 8,611,753; 8,611,754; 8,611,755; 8,611,756; 8,611,757; 8,611,758; 8,611,759; 8,611,760; 8,611,761; 8,611,762; 8,611,763; 8,611,764; 8,611,765; 8,611,766; 8,611,767; 8,611,768; 8,611,769; 8,611,770; 8,611,771; 8,611,772; 8,611,773; 8,611,774; 8,611,775; 8,611,776; 8,611,777; 8,611,778; 8,611,779; 8,611,780; 8,611,781; 8,611,782; 8,611,783; 8,611,784; 8,611,785; 8,611,786; 8,611,787; 8,611,788; 8,611,789; 8,611,790; 8,611,791; 8,611,792; 8,611,793; 8,611,794; 8,611,795; 8,611,796; 8,611,797; 8,611,798; 8,611,799; 8,611,800; 8,611,801; 8,611,802; 8,611,803; 8,611,804; 8,611,805; 8,611,806; 8,611,807; 8,611,808; 8,611,809; 8,611,810; 8,611,811; 8,611,812; 8,611,813; 8,611,814; 8,611,815; 8,611,816; 8,611,817; 8,611,818; 8,611,819; 8,611,820; 8,611,821; 8,611,822; 8,611,823; 8,611,824; 8,611,825; 8,611,826; 8,611,827; 8,611,828; 8,611,829; 8,611,830; 8,611,831; 8,611,832; 8,611,833; 8,611,834; 8,611,835; 8,611,836; 8,611,837; 8,611,838; 8,611,839; 8,611,840; 8,611,841; 8,611,842; 8,611,843; 8,611,844; 8,611,845; 8,611,846; 8,611,847; 8,611,848; 8,611,849; 8,611,850; 8,611,851; 8,611,852; 8,611,853; 8,611,854; 8,611,855; 8,611,856; 8,611,857; 8,611,858; 8,611,859; 8,611,860; 8,611,861; 8,611,862; 8,611,863; 8,611,864; 8,611,865; 8,611,866; 8,611,867; 8,611,868; 8,611,869; 8,611,870; 8,611,871; 8,611,872; 8,611,873; 8,611,874; 8,611,875; 8,611,876; 8,611,877; 8,611,878; 8,611,879; 8,611,880; 8,611,881; 8,611,882; 8,611,883; 8,611,884; 8,611,885; 8,611,886; 8,611,887; 8,611,888; 8,611,889; 8,611,890; 8,611,891; 8,611,892; 8,611,893; 8,611,894; 8,611,895; 8,611,896; 8,611,897; 8,611,898; 8,611,899; 8,611,900; 8,611,901; 8,611,902; 8,611,903; 8,611,904; 8,611,905; 8,611,906; 8,611,907; 8,611,908; 8,611,909; 8,611,910; 8,611,911; 8,611,912; 8,611,913; 8,611,914; 8,611,915; 8,611,916; 8,611,917; 8,611,918; 8,611,919; 8,611,920; 8,611,921; 8,611,922; 8,611,923; 8,611,924; 8,611,925; 8,611,926; 8,611,927; 8,611,928; 8,611,929; 8,611,930; 8,611,931; 8,611,932; 8,611,933; 8,611,934; 8,611,935; 8,611,936; 8,611,937; 8,611,938; 8,611,939; 8,611,940; 8,611,941; 8,611,942; 8,611,943; 8,611,944; 8,611,945; 8,611,946; 8,611,947; 8,611,948; 8,611,949; 8,611,950; 8,611,951; 8,611,952; 8,611,953; 8,611,954; 8,611,955; 8,611,956; 8,611,957; 8,611,958; 8,611,959; 8,611,960; 8,611,961; 8,611,962; 8,611,963; 8,611,964; 8,611,965; 8,611,966; 8,611,967; 8,611,968; 8,611,969; 8,611,970; 8,611,971; 8,611,972; 8,611,973; 8,611,974; 8,611,975; 8,611,976; 8,611,977; 8,611,978; 8,611,979; 8,611,980; 8,611,981; 8,611,982; 8,611,983; 8,611,984; 8,611,985; 8,611,986; 8,611,987; 8,611,988; 8,611,989; 8,611,990; 8,611,991; 8,611,992; 8,611,993; 8,611,994; 8,611,995; 8,611,996; 8,611,997; 8,611,998; 8,611,999; 8,611,1000.



9025 Centre Pointe Dr., Suite 400, West Chester, OH 45069
 800-338-1122 513-645-7000 513-645-7993 FAX

REFERENCE DETAIL
 CDS 4045-8-C
 CONCENTRIC INTERNALS

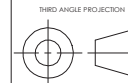

UNLESS OTHERWISE SPECIFIED
 DIMENSIONS ARE IN INCHES

TOLERANCES:
 FRACTIONAL $\pm 1/16$
 ANGLES ± 1 DEGREE
 TWO PLACE DECIMAL ± 0.06
 THREE PLACE DECIMAL ± 0.030

PART NUMBER: 325-000796	
APPROVED BY: M. BROOKS	DRAWN BY: C. CALDON
APPROVED BY DATE: 2022.03.08	DRAWN BY DATE: 2022.02.15 </

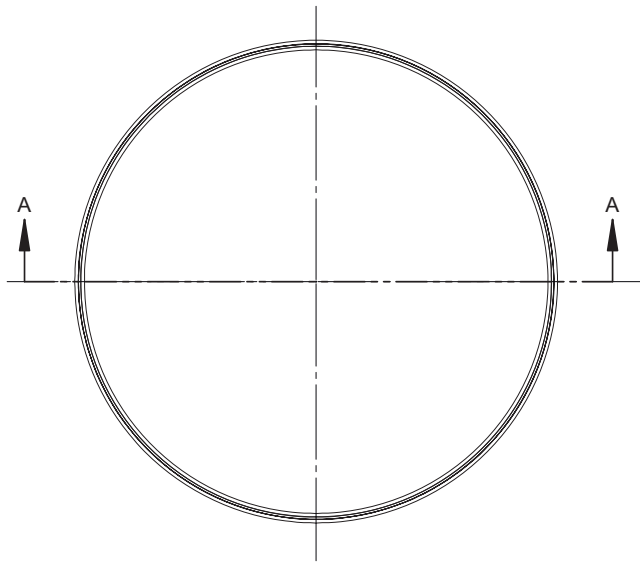

TOP VIEW

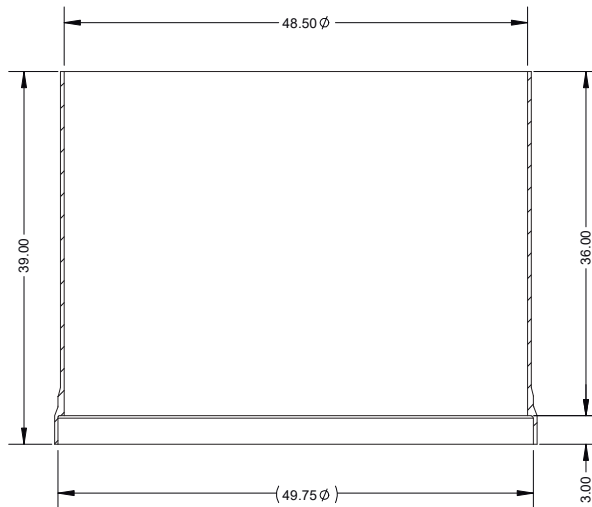

SECTION A-A

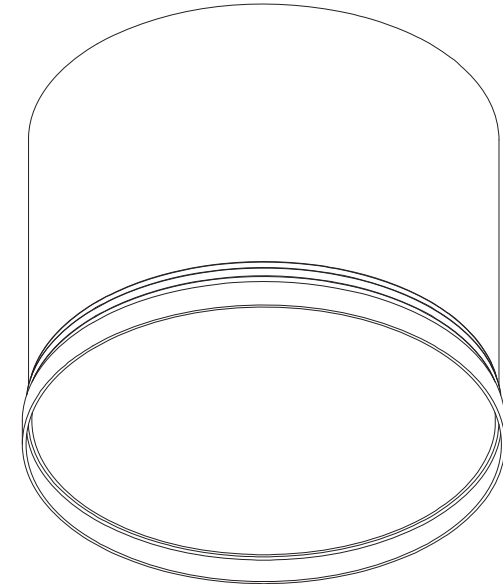

ISOMETRIC VIEW

- NOTES:
 1. SEE SITE SPECIFIC DRAWINGS FOR REQUIRED CYLINDER EXTENSION HEIGHT
 2. SEE CYLINDER EXTENSION INSTALLATION GUIDE FOR ADDITIONAL INFORMATION

The design and information shown on this drawing is provided as a service to the project owner, engineer and contractor by Contech Engineered Solutions LLC, or one of its affiliated companies ("Contech"). Neither this drawing, nor any part thereof, may be used, reproduced or modified in any manner without the prior written consent of Contech. Failure to comply with the user's terms and conditions expressly disclaims any liability or responsibility for such use.

If discrepancies between the supplied information upon which the drawing is based and actual field conditions are encountered as site work progresses, these discrepancies must be reported to Contech immediately for re-evaluation of the design. Contech accepts no liability for designs based on missing, incomplete or inaccurate information supplied by others.



THE PRODUCT MAY BE PROTECTED BY ONE OR MORE OF THE FOLLOWING U.S. PATENTS: 8,718,018; 8,641,725; 8,611,045; 8,601,104; RELATED FOREIGN PATENTS, OR OTHER PATENTS PENDING.



9025 Centre Pointe Dr., Suite 400, West Chester, OH 45069
 800-338-1122 513-645-7000 513-645-7993 FAX

REFERENCE DETAIL
 3 FT CYLINDER EXTENSION
 CDS - 40 SERIES

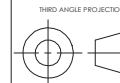

UNLESS OTHERWISE SPECIFIED
 DIMENSIONS ARE IN INCHES

TOLERANCES:
 FRACTIONAL $\pm 1/16$
 ANGLES ± 1 DEGREE
 TWO PLACE DECIMAL ± 0.06
 THREE PLACE DECIMAL ± 0.030

PART NUMBER: 325-002784	
APPROVED BY: M. BROOKS	DRAWN BY: J. BELL
APPROVED BY DATE: 2022.03.10	DRAWN BY DATE: 2022.02.11
SCALE: N/A	REV: B
SHEET 1 OF 1	

