

Job Name: 25-4504 ADS FedEx Freight  
 Job Location: Bowling Green, KY  
 Contractor: ADS Advances Drainage Systems, Inc.

Plant: Beaver Dam  
 12/1/2025 1:58:32 PM

Tech: J. Coppage  
 PC: C. Goff



**Structure ID: S8 (2)**  
**P3 MH096RS54**

**MH RISER**

- P5) 24" x 24" - CASTING HEIGHT - 4"
- P4) 96" - MH FLAT TOP w/24"x24" Hole - 12"
- P3) 96" - MH RISER - 54"
- P2) 96" - MH RISER - 84"
- P1) 96" - MH MONOBASE 13F, Custom Ht - 30"
- 1) ASSEMBLY REQUIRED
- 3) 96" - Conseal CS-102 1.00"
- 1) 24" x 24" - Conseal CS-102 1.00"
- 2) Hole - 32
- 1) Hole - 22

- 0 lb  
 9698 lb  
 11928 lb  
 20926 lb  
 18608 lb  
 0 lb  
 0 lb  
 0 lb  
 0 lb  
 0 lb
- Structure Notes:**
1. JR HOE HOE-280T PROVIDED BY ICAST.
  2. PER ASTM C478 SPECIFICATIONS.
  3. CONCRETE = 4,000 PSI AT 28 DAYS.
  4. REINFORCING PER ASTM A615 (GRADE 60).  
 - TOP SLAB (As .31) #5 BARS AT 6" C.C.E.W.  
 - RISER/WALLS (As .18)  
 - FLOOR TOP AND BOTTOM MAT (As .47) #5 BARS AT 8" C.C.E.W.

Structure Total: 61160 lb

Rim: 526.89' Rim to Invert: 4.33' Slack: 1.96" Sump: 134" Step Position:

Position	Elev	Angle	Ext. (cw)	Pipe	Pipe OD	Connector	Hole	Horz Size	Up (")	Offset
Invert 1	522.56'	0°	0"	24" ADS N-12	28"	Hole 32	32"	32.624"	11"	0"
Invert 2	523.18'	72°	71.628"	15" ADS N-12	18"	Hole 22	22"	22.197"	18.94"	0"
Invert 3	522.56'	180°	179.071"	24" ADS N-12	28"	Hole 32	32"	32.624"	11"	0"
Invert 4										
Invert 5										
Invert 6										
Invert 7										
Invert 8										

**RIGHT-SIDE UP VIEW (int. dimensions)**

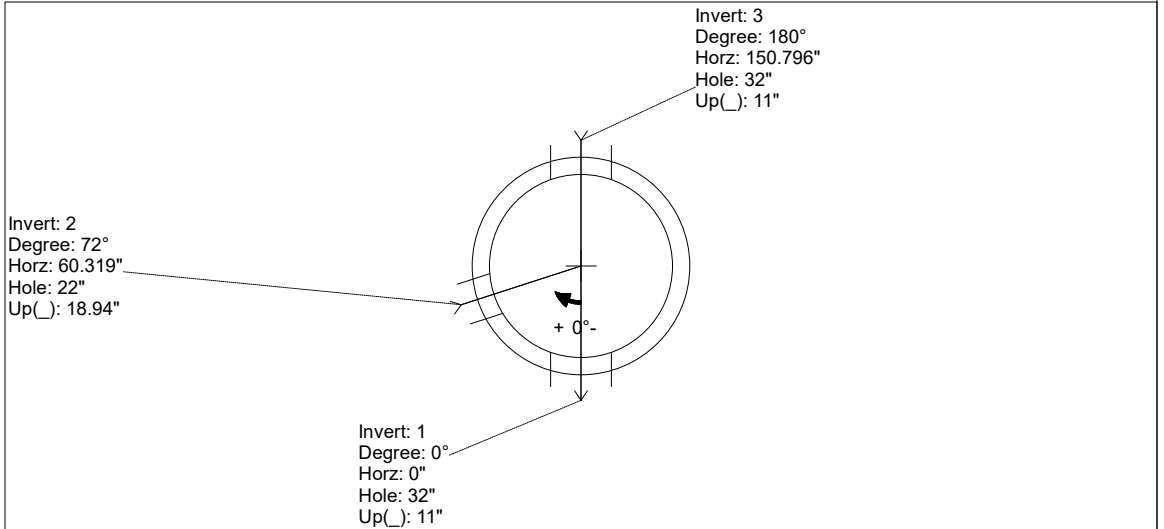
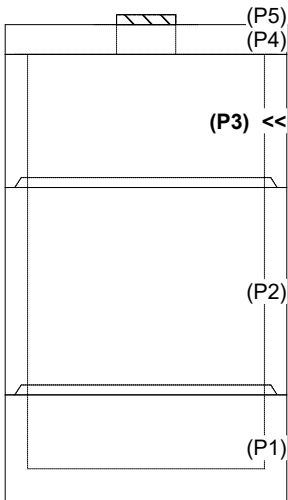

**INSIDE WALL DIMENSIONS**

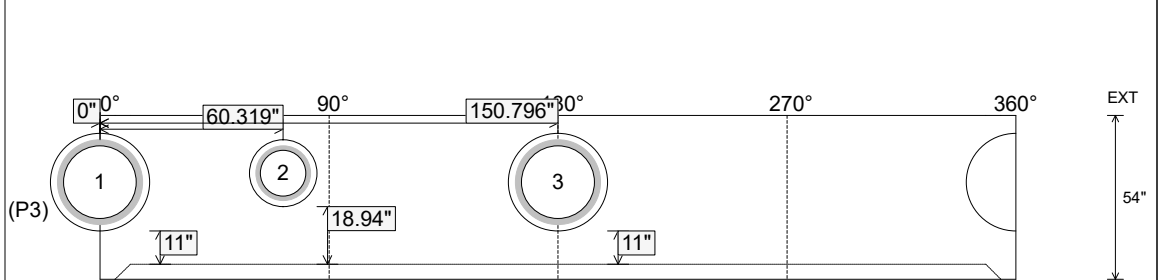

Coating (Int): Coating (Ext):	Seam Up: Flat Seam Dn: Groove	Wall Thickness: 9" Floor Height: 0"	Height (Int): 54" Height (Ext): 54"	Weight (Net): 11928 lb Volume (Net): 3.05cu.yd
----------------------------------	----------------------------------	--	--	---