

Job Name: 25-4503 TM Retail
Job Location: Somerset, KY
Contractor: Weddle Enterprises, Inc

PC: C. Goff
 TECH: J. Horsley
 Plant: 100



Structure ID: DI 1 (6)

Spec: Storm
 Type: STM.MH (Recessed pipe)
 Size: 48"

Rim: 1001.3'
 Invert: 997.8'
 Rim to Invert: 3.5'

Sump: 0"
 Floor (Top): 997.8'
 Floor Height: 6"

Floor (Bot): 997.3'
 Overall Height: 3.958'
 Slack: 0.5"

Structure Notes:

1. PER ASTM C478 SPECIFICATIONS.
2. CONCRETE = 4,000 PSI AT 28 DAYS.
3. CASTING BY OTHERS (HOE 580 F/G).

REINFORCING PER ASTM A615 (GRADE 60).
 - TOP SLAB = H2O LOADING.
 - RISER/WALLS (As .12)
 - FLOOR (As .31) #5 BARS AT 12" C.C.E.W.

STRUCTURE SUMMARY:

P3) 18" x 36" - CASTING HEIGHT - 5.5"	0 lb
P2) 48" - MH FLAT TOP w/18"x36" Hole F/G - 12"	2008 lb
P1) 48" - MH BASE T/n - 24"	2872 lb
1) 48" - SGL 1"x14.5' Butyl (2x)	0 lb
1) Hole - 20	0 lb
2) MH Step ML-10-TDS-NCR - 10"	0 lb
Structure Total:	4879 lb

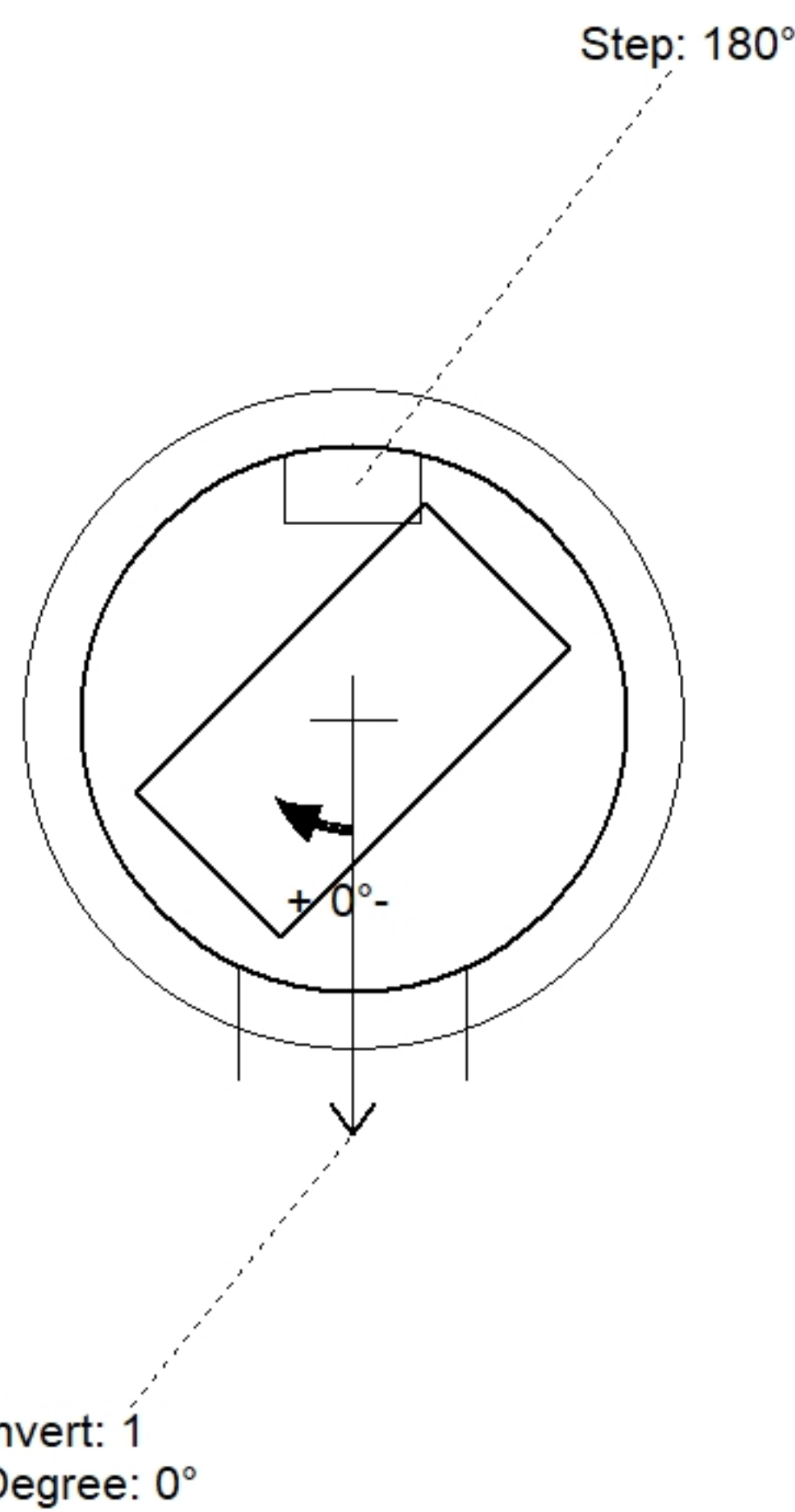

Position	Elev	Angle	Pipe	Pipe OD	Hole	Connector	Up ()	Ref
Rim	1001.3'							
Reducer								
Invert 1	997.8'	0°	15" HDPE	17.6"	20"	Hole 20	-1.25"	P1
Invert 2								
Invert 3								
Invert 4								
Invert 5								
Invert 6								
Invert 7								
Invert 8								

Cast (Int. Dim.) - Interior Dimensions

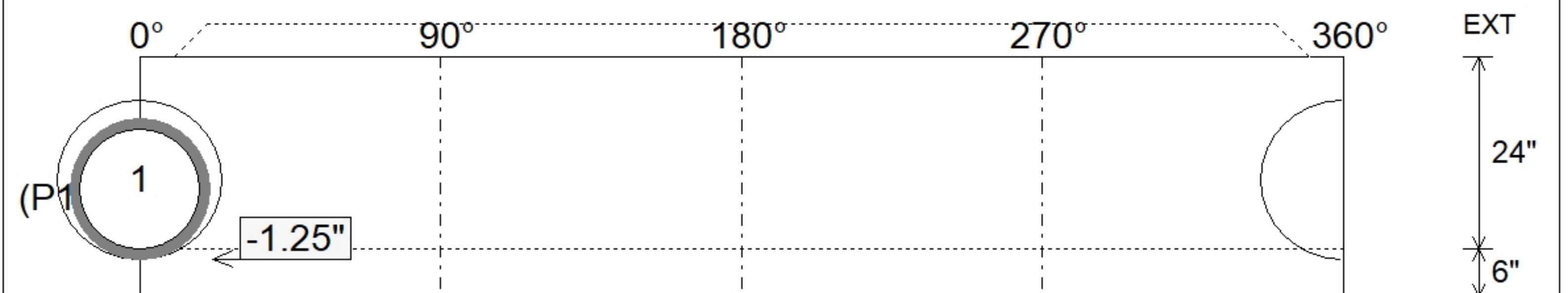
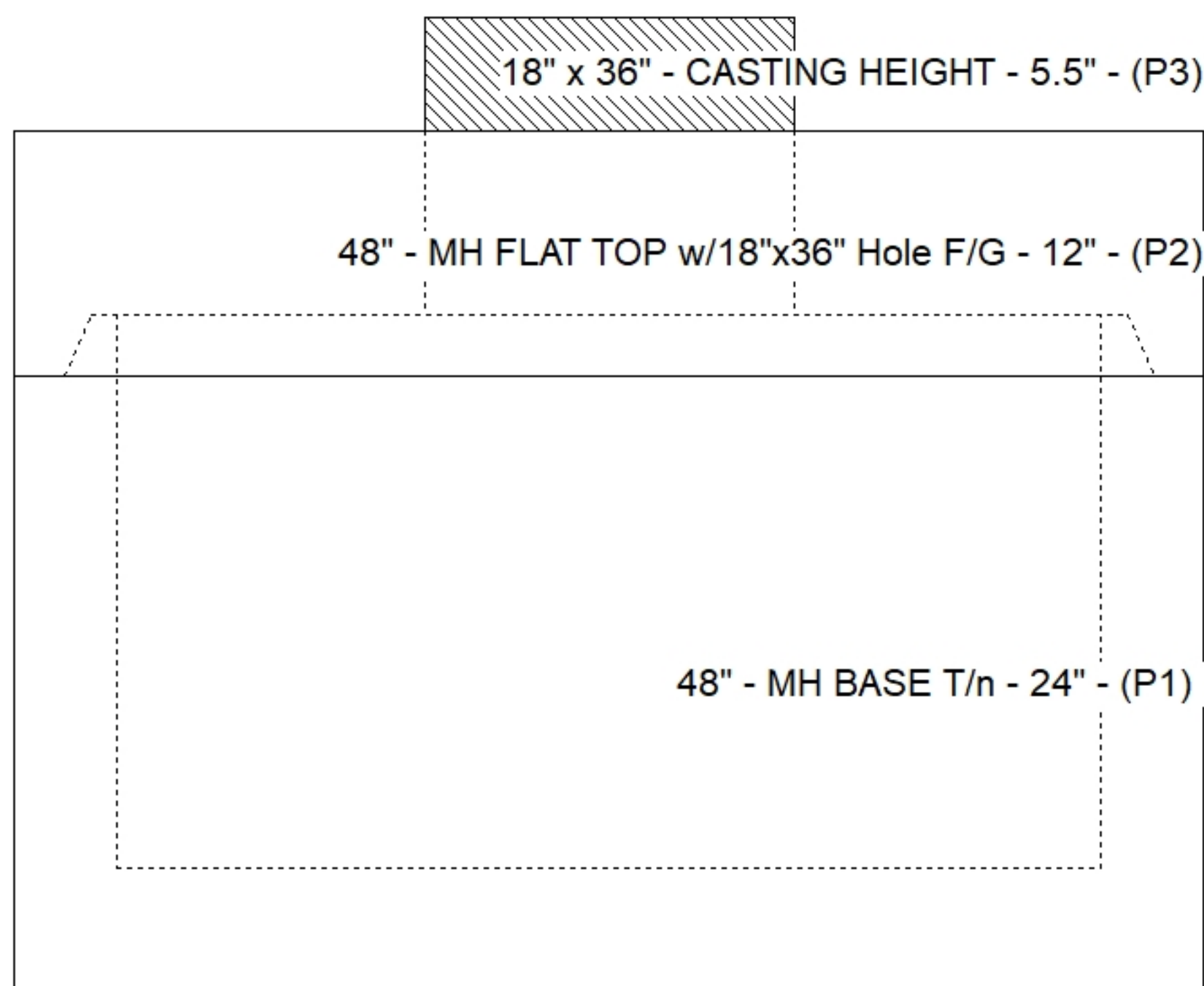

Submittal Drawing
 12/16/2025 2:11:43 PM

SUBMITTAL
 APPROVED BY: