

Job Name: 25-4488 - WV DOT Wood Co NHPP-0068(192)
 Job Location: Parkersburg, WV
 Contractor: Triton Construction

Plant: 100
 3/26/2026 1:41:44 PM

Tech: Jared - F
 PC: E. Bradley



Structure ID: MH-07

P1 MH060BAVF

MH BASE Custom Ht T/n

- P4) 24" - CASTING HEIGHT - 8.85"
- P3) 60" - MH FLAT TOP w/ 24" ECC Hole F/G - 13"
- P2) 60" - MH RISER T/G - 24"
- P1) 60" - MH BASE Custom Ht T/n - 59"
- 1) CASTING - NEENAH R-1785 (F/C)
- 2) 60" - Conseal CS-102 1.00"
- 1) Hole - 40
- 1) Hole - 38
- 7) MH Step ML-10-TDS-NCR - 10"

0 lb
 2869 lb
 2505 lb
 7601 lb
 294 lb
 0 lb
 0 lb
 0 lb
 0 lb
 0 lb

Structure Total: 13269 lb

Structure Notes:
 WV DOT STATE PROJECT
 1. PER ASTM C478 SPECIFICATIONS.
 2. CONCRETE = 4,000 PSI AT 28 DAYS.
 3. INVERT CHANNEL (BY OTHERS).
 4. CASTING BY I-CAST (NEENAH R-1785 (F/C)).

REINFORCING PER ASTM A615 (GRADE 60).
 - TOP SLAB (As .62) #5 BARS AT 6" C.C.E.W..
 - RISER/WALLS (As .18)
 - FLOOR (As .37) #5 BARS AT 10" C.C.E.W.

Rim: 602.3' Rim to Invert: 8.8' Slack: 0.75" Sump: 0" Step Position: 180

Position	Elev	Angle	Ext. (cw)	Pipe	Pipe OD	Connector	Hole	Horz Size	Up ()	Offset
Invert 1	593.5'	0°	0"	30" RCP B WALL	37"	Hole 40	40"	43.784"	-3.5"	0"
Invert 2	593.62'	263°	165.25"	30" HDPE	35.1"	Hole 38	38"	41.151"	-1.125"	0"
Invert 3										
Invert 4										
Invert 5										
Invert 6										
Invert 7										
Invert 8										

RIGHT-SIDE UP VIEW (int. dimensions)

UPSIDE-DOWN VIEW (int. dimensions)

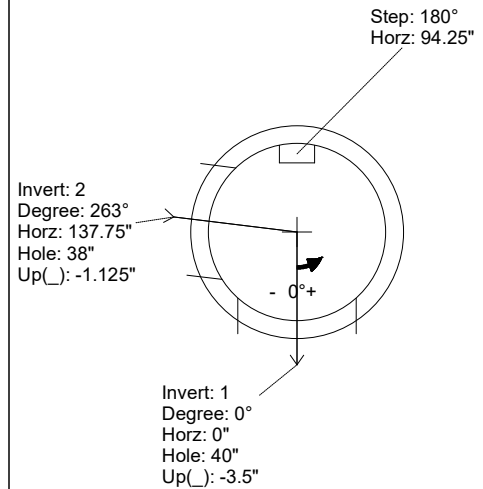
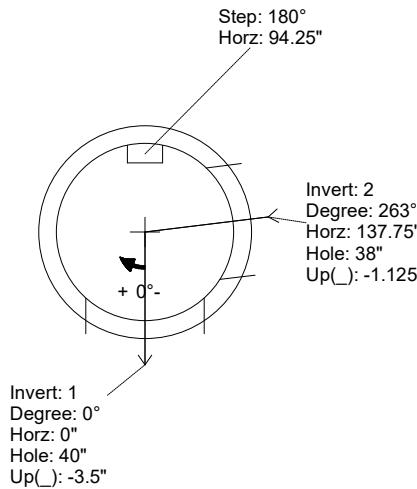
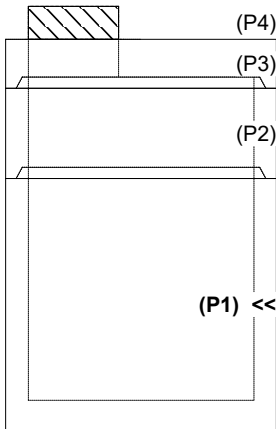

INSIDE WALL DIMENSIONS

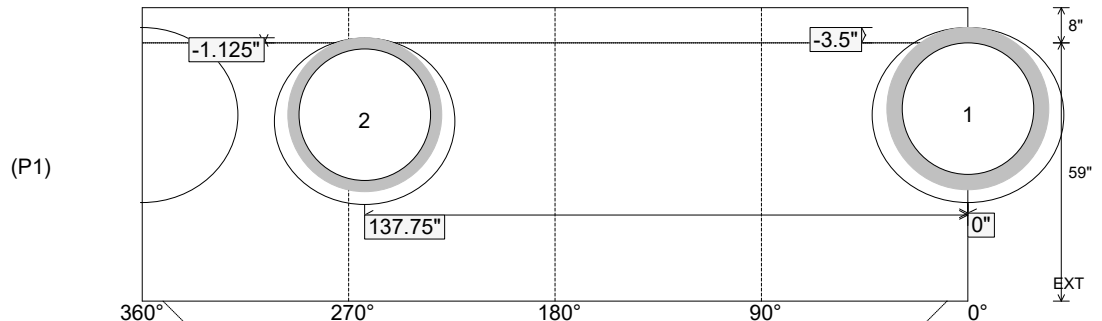

Coating (Int):
 Coating (Ext):

Seam Up: Tongue
 Seam Dn: n/a

Wall Thickness: 6"
 Floor Height: 8"

Height (Int): 59"
 Height (Ext): 67"

Weight (Net): 7601 lb
 Volume (Net): 1.94cu.yd