

Job Name: 25-4488 - WVDOT Wood Co NHPP-0068(192) Job Location: Parkersburg, WV Contractor: Triton Construction	Plant: 100	Tech: Jared - F
	3/26/2026 1:44:54 PM	PC: E. Bradley

Structure ID: MH-01

P2 MH048CN36

ECC CONE w/ 24" HOLE F/G

- P3) 24" - CASTING HEIGHT - 8.85"
- P2) 48" - ECC CONE w/ 24" HOLE F/G - 36"
- P1) 48" - MH BASE Custom Ht T/n - 56"
- 1) CASTING - NEENAH R-1785 (F/C)
- 1) 48" - Conseal CS-102 1.00"
- 1) Hole - 24
- 1) Hole - 26
- 8) MH Step ML-10-TDS-NCR - 10"

	0 lb
	3000 lb
	4812 lb
	294 lb
	0 lb
	0 lb
	0 lb
	0 lb
	0 lb
Structure Total:	8106 lb

Structure Notes:
****WVDOT STATE PROJECT****
 1. PER ASTM C478 SPECIFICATIONS.
 2. CONCRETE = 4,000 PSI AT 28 DAYS.
 3. INVERT CHANNEL (BY OTHERS).
 4. CASTING BY I-CAST (NEENAH R-1785 (F/C)).

REINFORCING PER ASTM A615 (GRADE 60).
 - TOP SLAB (As .62) #5 BARS AT 6" C.C.E.W..
 - RISER/WALLS (As .12)
 - FLOOR (As .31) #5 BARS AT 12" C.C.E.W.

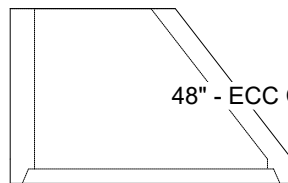
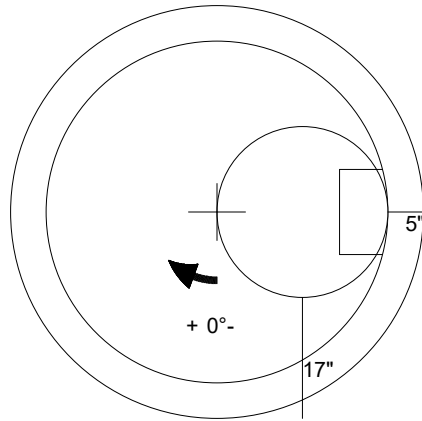

48" - ECC CONE w/ 24" HOLE F/G - 36" - (P2)

Coating (Int): Coating (Ext):	Seam Up: Flat Seam Dn: Groove	Wall Thickness: 5"	Height (Ext): 36"	Weight (Net): 3000 lb Volume (Net): 0.5cu.yd
----------------------------------	----------------------------------	--------------------	-------------------	---