

Job Name: 25-4430 KYTC Daviess Co Call 104 (2511035)
 Job Location: Owensboro, KY
 Contractor: Ragle, Inc.

Plant: 100

3/11/2026 2:13:54 PM

Tech: Jared - A

PC: Andy Chambers



Structure ID: 8750 (27)

P1 BX3636-08BAVF

BOX BASE 8inW, 8inF, Variable Ht

- P2) 36" x 36" - CB FLAT TOP 8"W SOLID - 8"
- P1) 36" x 36" - BOX BASE 8inW, 8inF, Variable Ht - 25"
- 1) 36" x 36" - Conseal CS-102 1.00"
- 2) Hole - 24"

1815 lb
 4162 lb
 0 lb
 0 lb

 Structure Total: 5977 lb

- Structure Notes:
 ***KYTC STATE PROJECT**
1. KYTC JUNCTION BOX / PER ASTM C913 SPEC'S.
 2. CONCRETE = 4,000 PSI AT 28 DAYS.
 3. SOLID TOP SLAB - NO CASTING.
 4. REINFORCING PER ASTM A615 (GRADE 60).
 - TOP SLAB (As. 62) #5 BARS AT 6" C.C.E.W.
 - WALLS (As .31) #5 BARS AT 12" C.C.E.W.
 - FLOOR (As .31) #5 BARS AT 12: C.C.E.W.

Rim: 448' Rim to Invert: 3' Slack: 3" Sump: 0" Step Position:

Position	Elev	Angle	Ext. (cw)	Pipe	Pipe OD	Connector	Hole	Horz Size	Up ()	Offset
Invert 1	445'	270°	26"	18" HDPE	21.2"	Hole 24	24"	24"	-3"	0"
Invert 2	445'	180°	26"	18" HDPE	21.2"	Hole 24	24"	24"	-3"	0"
Invert 3										
Invert 4										
Invert 5										
Invert 6										
Invert 7										
Invert 8										

RIGHT-SIDE UP VIEW (int. dimensions)

UPSIDE-DOWN VIEW (int. dimensions)

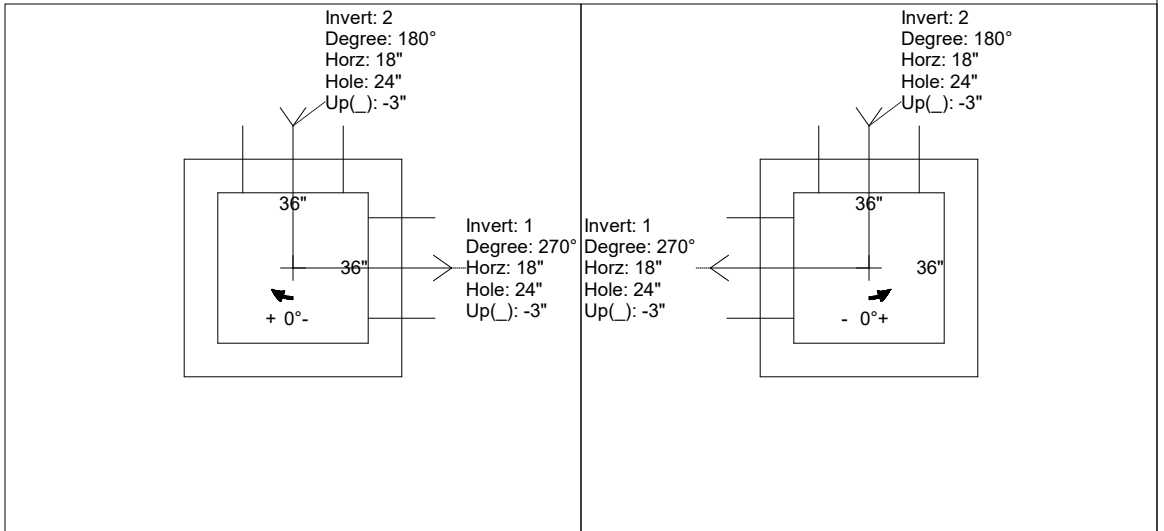
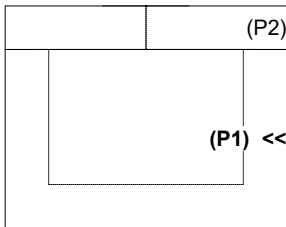

INSIDE WALL DIMENSIONS

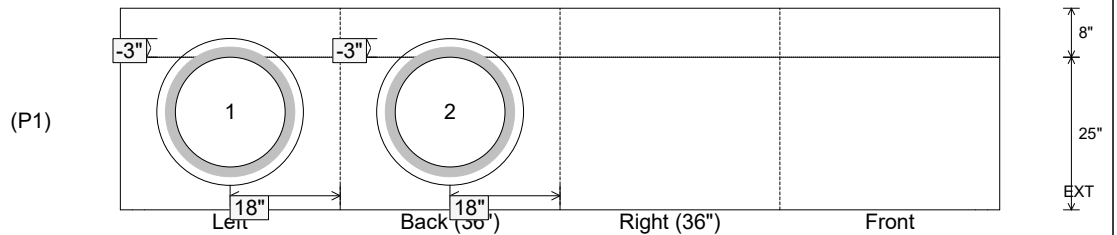

Coating (Int):
 Coating (Ext):

Seam Up: Flat
 Seam Dn: n/a

Wall Thickness: 8"
 Floor Height: 8"

Height (Int): 25"
 Height (Ext): 33"

Weight (Net): 4162 lb
 Volume (Net): 1.06cu.yd