

Job Name: 25-4430 KYTC Daviess Co Call 104 (2511035)
 Job Location: Owensboro, KY
 Contractor: Ragle, Inc.

Plant: 100
 3/11/2026 2:13:37 PM

Tech: Jared - A
 PC: Andy Chambers



Structure ID: 7428L (6)

P1 BX2436-08BVF

BOX BASE 8inW, 8inF, Variable Ht

- P3) 24" x 120" - CB INLET KY A 10' TOP RIGHT - 10"
- P2) 24" x 120" - CB INLET KY A 10' BOTTOM RIGHT - 18"
- P1) 24" x 36" - BOX BASE 8inW, 8inF, Variable Ht - 32"
- 1) CASTING - HOE KY-206 F/C (KY TY1)
- 1) 24" x 36" - Conseal CS-102 1.00"
- 2) Hole - 24"

Structure Total: 13004 lb

- Structure Notes:**
- ** KYTC STATE PROJECT **
 - 1. HOE KY-206 F/C (KY TY1) PROVIDED BY ICAST.
 - 2. PER KYTC CBI TYPE A / ASTM C913 SPEC'S.
 - 3. CONCRETE = 4,000 PI AT 28 DAYS.
 - 4. NO INVERT CHANNEL.
 - 5. REINFORCING PER ASTM A615 (GRADE 60).
 - TOP PHASE (As .62) #5 BARS AT 6" C.C.E.W.
 - WALLS (As .31) #5 BARS AT 12" C.C.E.W.
 - FLOOR (As .31) #5 BARS AT 12" C.C.E.W.
 - 6. THE LISTED RIM ELEVATION IS THE GIVEN FLOWLINE ELEVATION +8".

Rim: 445.31' Rim to Invert: 5.17' Slack: 2.04" Sump: 0" Step Position:

Position	Elev	Angle	Ext. (cw)	Pipe	Pipe OD	Connector	Hole	Horz Size	Up ()	Offset
Invert 1	440.14'	90°	26"	18" HDPE	21.2"	Hole 24	24"	24"	-3"	0"
Invert 2	440.14'	180°	20"	18" HDPE	21.2"	Hole 24	24"	24"	-3"	0"
Invert 3										
Invert 4										
Invert 5										
Invert 6										
Invert 7										
Invert 8										

RIGHT-SIDE UP VIEW (int. dimensions)

UPSIDE-DOWN VIEW (int. dimensions)

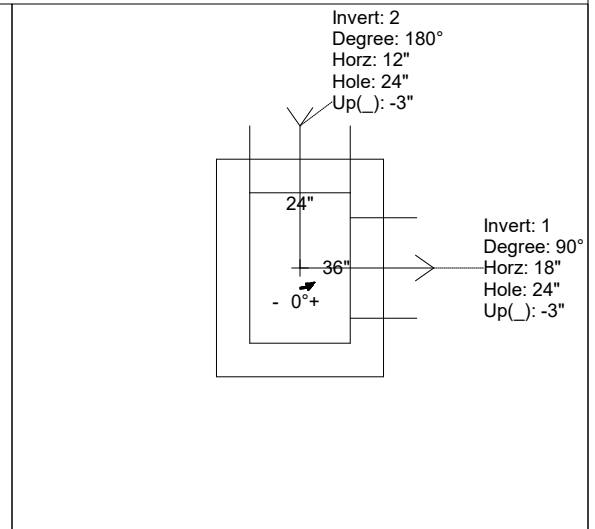
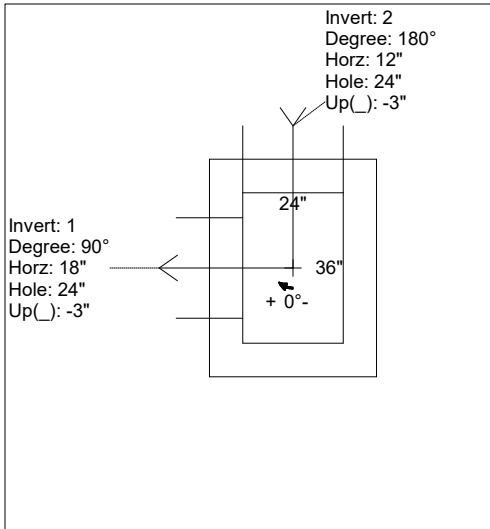
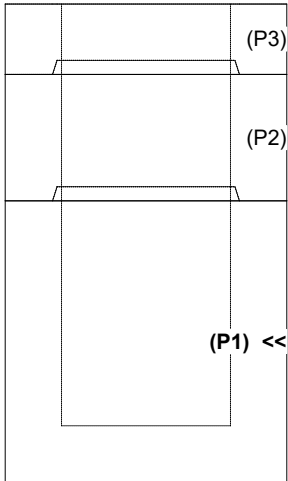

INSIDE WALL DIMENSIONS

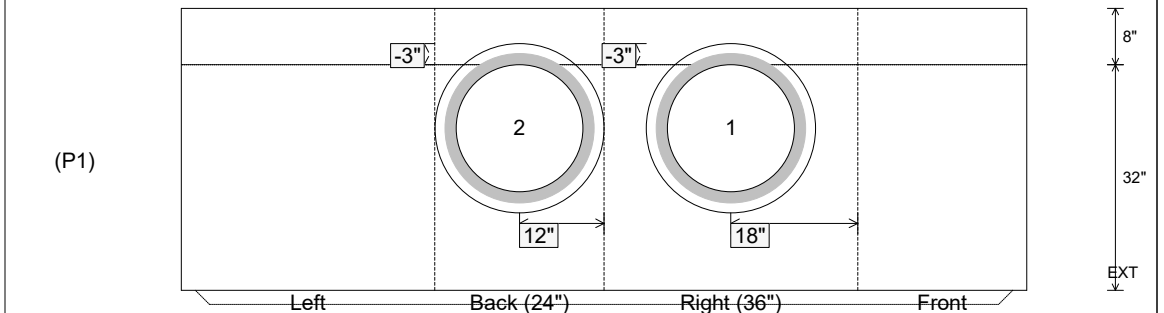

Coating (Int): Coating (Ext):	Seam Up: Tongue Seam Dn: n/a	Wall Thickness: 8" Floor Height: 8"	Height (Int): 32" Height (Ext): 40"	Weight (Net): 4130 lb Volume (Net): 1.06cu.yd
----------------------------------	---------------------------------	--	--	--