

Job Name: 25-4430 KYTC Daviess Co Call 104 (2511035)  
 Job Location: Owensboro, KY  
 Contractor: Ragle, Inc.

Plant: 100  
 3/11/2026 2:13:57 PM

Tech: Jared - A  
 PC: Andy Chambers



**Structure ID: 6001R (31)**

**P1 MH048BAVF**

**MH BASE Custom Ht**

- P3) 24" - CASTING HEIGHT - 8"
- P2) 48" - MH FLAT LID w/24in ECC Hole - 12"
- P1) 48" - MH BASE Custom Ht - 65"
- 1) CASTING - HOE KY-510 F/C (KY TY.2)
- 1) 48" - Conseal CS-102 1.00"
- 2) Hole - 24"
- 5) MH Step ML-10-TDS-NCR - 10"

Structure Notes:  
 \*\*KYTC STATE PROJECT\*\*  
 1. HOE KY-510 F/C (KY TY.2) PROVIDED BY ICAST.  
 2. PER KYTC MH A / ASTM C478 SPEC'S.  
 3. CONCRETE = 4,000 PSI AT 28 DAYS.  
 4. REINFORCING PER ASTM A615 (GRADE 60.)  
 - TOP SLAB (As .62) #5 BARS AT 6" C.C.E.W.  
 - RISER/WALLS (As .12)  
 - FLOOR (As .31) #5 BARS AT 12" C.C.E.W.  
 5. VERIFY THE STRUCTURE NAME.

0 lb  
 1561 lb  
 5477 lb  
 510 lb  
 0 lb  
 0 lb  
 0 lb  
 -----  
 Structure Total: 7548 lb

Rim: 451.31' Rim to Invert: 6.96' Slack: 1.52" Sump: 3" Step Position: 0°

Position	Elev	Angle	Ext. (cw)	Pipe	Pipe OD	Connector	Hole	Horz Size	Up ( )	Offset
Invert 1	444.35'	0°	0"	18" HDPE	21.2"	Hole 24	24"	25.133"	0"	0"
Invert 2	444.35'	150°	75.922"	18" HDPE	21.2"	Hole 24	24"	25.133"	0"	0"
Invert 3										
Invert 4										
Invert 5										
Invert 6										
Invert 7										
Invert 8										

RIGHT-SIDE UP VIEW (int. dimensions)

UPSIDE-DOWN VIEW (int. dimensions)

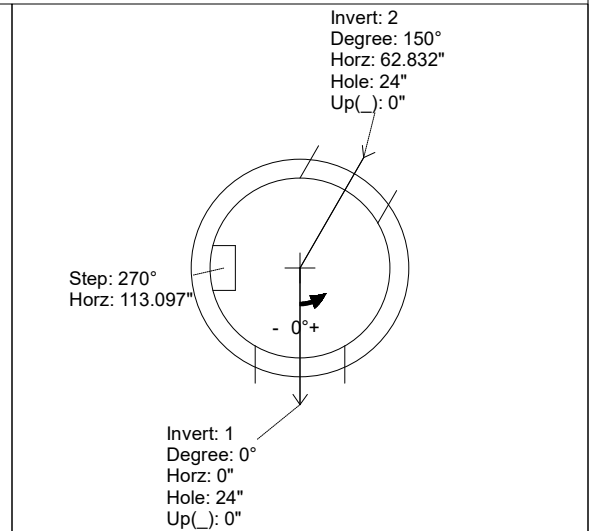
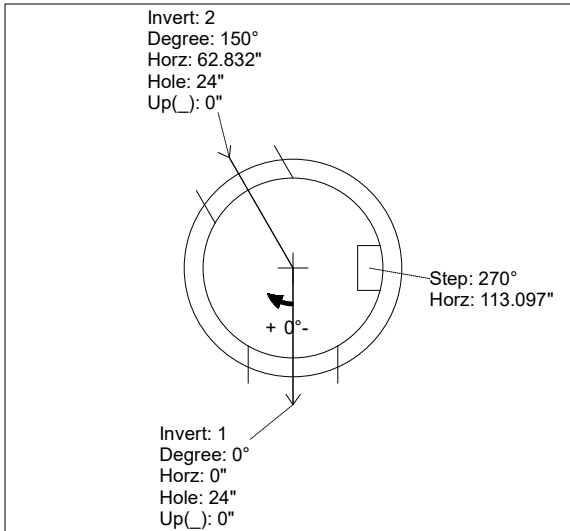
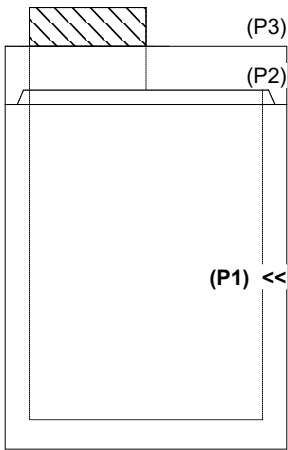

INSIDE WALL DIMENSIONS

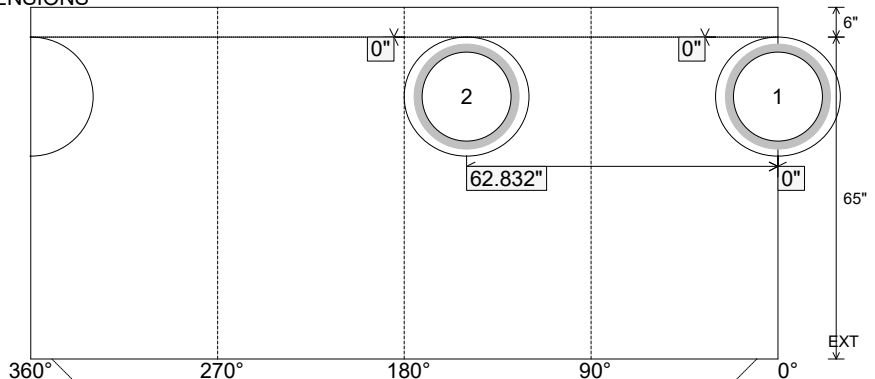

Coating (Int): Coating (Ext):	Seam Up: Tongue Seam Dn: n/a	Wall Thickness: 5" Floor Height: 6"	Height (Int): 65" Height (Ext): 71"	Weight (Net): 5477 lb Volume (Net): 1.4cu.yd
----------------------------------	---------------------------------	--	--	---