

Job Name: 25-4430 KYTC Daviess Co Call 104 (2511035)
 Job Location: Owensboro, KY
 Contractor: Ragle, Inc.

Plant: 100

3/11/2026 2:13:34 PM

Tech: Jared - A

PC: Andy Chambers



Structure ID: 4652L (3)

P1 BX2436-08BVF

BOX BASE 8inW, 8inF, Variable Ht

- P3) 24" x 120" - CB INLET KY A 10' TOP LEFT - 10"
- P2) 24" x 120" - CB INLET KY A 10' BOTTOM LEFT - 18"
- P1) 24" x 36" - BOX BASE 8inW, 8inF, Variable Ht - 32"
- 1) CASTING - HOE KY-206 F/C (KY TY1)
- 1) 24" x 36" - Conseal CS-102 1.00"
- 1) Hole - 24
- 1) Hole - 4

Structure Notes:

- ** KYTC STATE PROJECT **
- 1. HOE KY-206 F/C (KY TY1) PROVIDED BY ICAST.
- 2. PER KYTC CBI TYPE A / ASTM C913 SPEC'S.
- 3. CONCRETE = 4,000 PI AT 28 DAYS.
- 4. NO INVERT CHANNEL.
- 5. REINFORCING PER ASTM A615 (GRADE 60).
- TOP PHASE (As .62) #5 BARS AT 6" C.C.E.W.
- WALLS (As .31) #5 BARS AT 12" C.C.E.W.
- FLOOR (As .31) #5 BARS AT 12" C.C.E.W.
- 6. THE LISTED RIM ELEVATION IS THE GIVEN FLOWLINE ELEVATION +8".

Structure Total: 13225 lb

Rim: 451.1' Rim to Invert: 5.18' Slack: 2.16" Sump: 0" Step Position:

Position	Elev	Angle	Ext. (cw)	Pipe	Pipe OD	Connector	Hole	Horz Size	Up (")	Offset
Invert 1	445.92'	270°	26"	18" HDPE	21.2"	Hole 24	24"	24"	-3"	0"
Invert 2	448'	180°	20"	4" WEEP HOLE	4"	Hole 4	4"	4"	24.96"	0"
Invert 3										
Invert 4										
Invert 5										
Invert 6										
Invert 7										
Invert 8										

RIGHT-SIDE UP VIEW (int. dimensions)

UPSIDE-DOWN VIEW (int. dimensions)

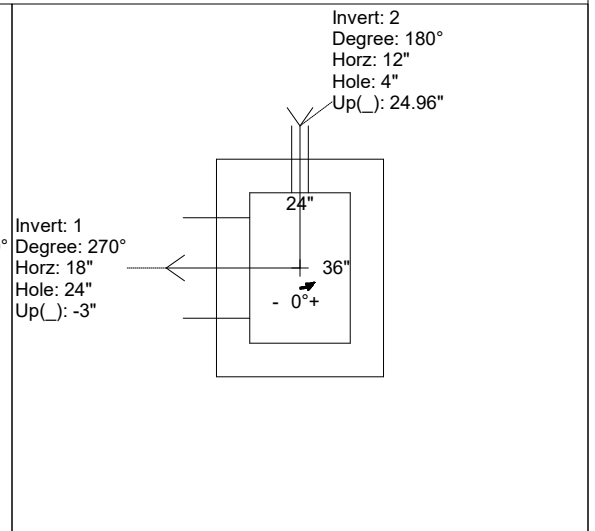
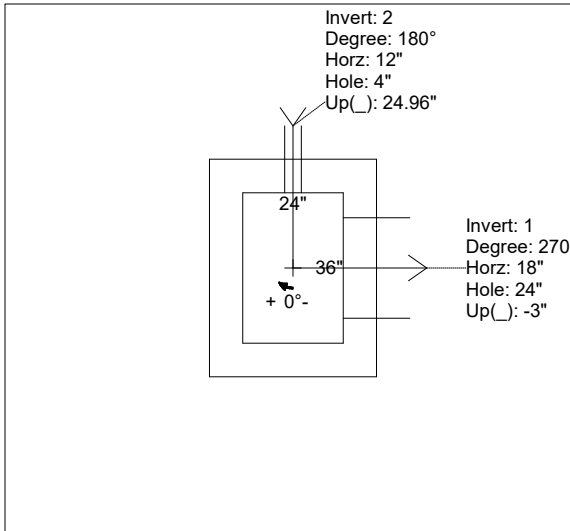
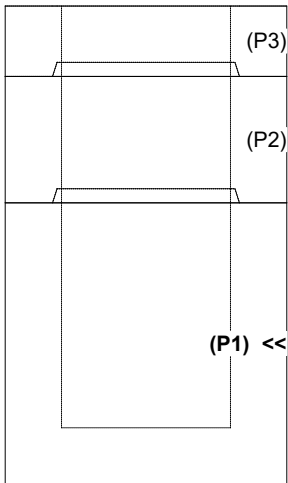

INSIDE WALL DIMENSIONS

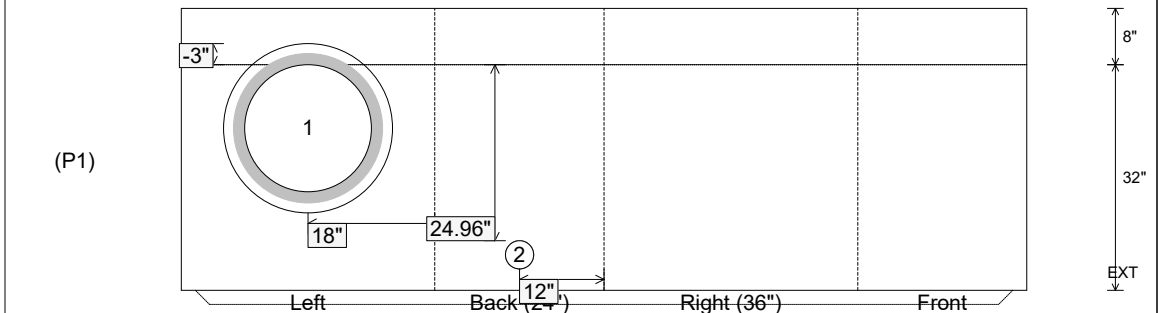

Coating (Int):
 Coating (Ext):

Seam Up: Tongue
 Seam Dn: n/a

Wall Thickness: 8"
 Floor Height: 8"

Height (Int): 32"
 Height (Ext): 40"

Weight (Net): 4349 lb
 Volume (Net): 1.11cu.yd