

Job Name: 25-4419 - East Bank Reginal Pump Station  
 Job Location: Nashville, TN 37213  
 Contractor: Garney Companies, Inc.

Plant: 100  
 1/28/2026 2:53:01 PM

Tech: J. Horsley - F  
 PC: J. Jarvis



**Structure ID: ST102**

**P3 MH084LD15-24ECC**

**MH FLAT TOP w/24" ECC Hole F/G**

- P4) 24" - CASTING HEIGHT - 7"
- P3) 84" - MH FLAT TOP w/24" ECC Hole F/G - 15"
- P2) 84" - MH RISER Custom Ht T/G - 69"
- P1) 84" - MH BASE T/n - 96"
- 1) CASTING - JBS 1150 F/C STORM
- 2) 84" - Conseal CS-102 1.00"
- 2) Hole - 48
- 8) MH Step ML-10-TDS-NCR - 10"

	0 lb
	9316 lb
	13388 lb
	21338 lb
	250 lb
	0 lb
	0 lb
	0 lb
Structure Total:	44292 lb

- Structure Notes:**
1. PER ASTM C-478 SPECIFICATIONS
  2. CONCRETE: 4,000 PSI AT 28 DAYS
  3. REINFORCEMENT - 2" MIN. REBAR CLEARANCE (TYP):
    - TOP MAT: #4 BAR @ 18" C.C. E.W. (GRADE 60)
    - BOTTOM MAT: #4 BAR @ 9" C.C. E.W. (GRADE 60)
  4. JBS 1150 FRAME & COVER "STORM" SUPPLIED BY ICAST
  5. LIFTERS: 4 EA. WRA016 CONAC WIRE ROPE ANCHORS FOR PLANT & FIELD HANDLING
  6. TOP SURFACE TO RECEIVE FLOATED FINISH

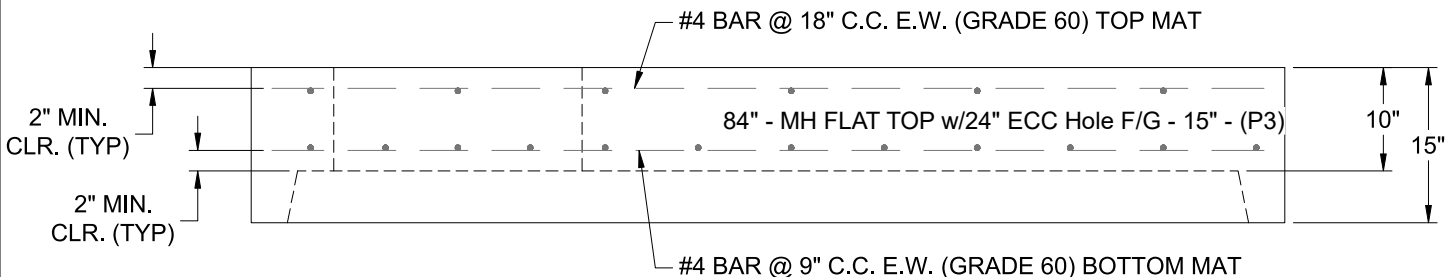
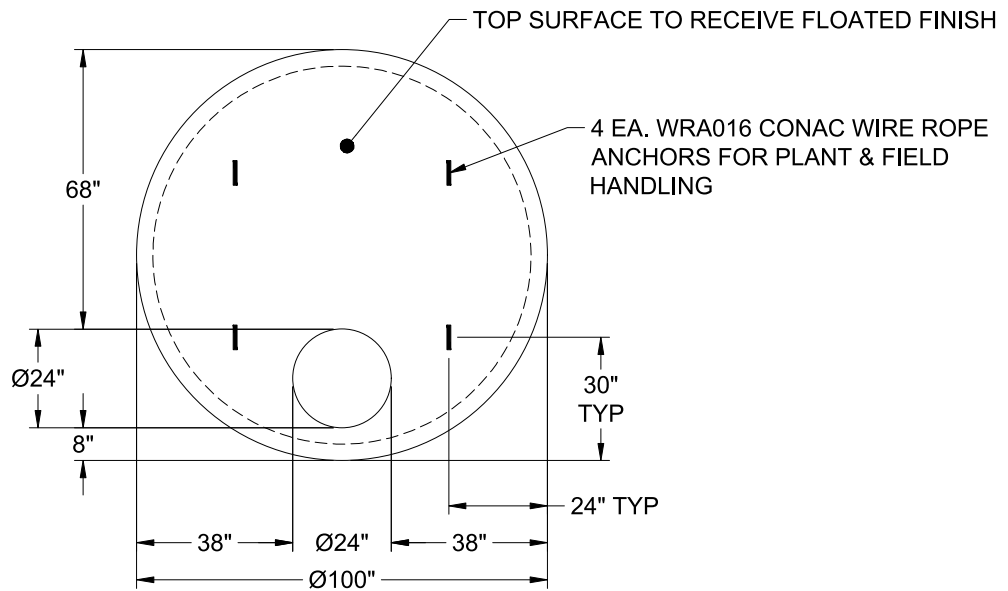

Coating (Int):  
 Coating (Ext):

Seam Up: Flat  
 Seam Dn: Groove

Wall Thickness: 8"

Height (Ext): 15"

Weight (Net): 9316 lb  
 Volume (Net): 2.38cu.yd