

Ø12" OPENING THROUGH TOP OF MONOTOP FOR 8" DI PIPE W/ LINK-SEAL CONNECTOR (CONNECTOR BY OTHERS)

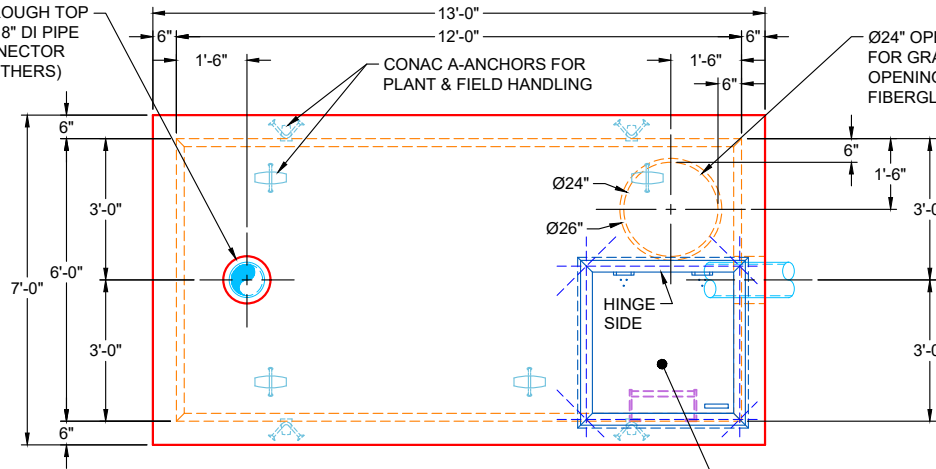

PLAN VIEW

Ø24" OPENING THROUGH FLOOR FOR GRAVEL SUMP BELOW - Ø26" OPENING RECESSED 1" FOR FIBERGLASS COVER

36" X 36" HATCH SUPPLIED BY OTHERS - TO BE CAST INTO TOP OF MONOTOP

GENERAL NOTES:

1. MANUFACTURED PER ASTM C-913 SPECIFICATIONS
2. CONCRETE: 5,000 PSI AT 28 DAYS
3. REINFORCEMENT:
- MONOTOP WALLS & TOP: #5 BAR @ 6" C.C. E.W. (GRADE 60)
- BASE WALLS & FLOOR: #5 BAR @ 6" C.C. E.W. (GRADE 60)
4. TOTAL WEIGHT: 34,740 LBS
- MONOTOP (6" WALLS & 6" TOP): 17,325 LBS
- BASE (6" WALLS & 6" FLOOR): 17,415 LBS
5. JOINTS SEALED WITH CONSEAL CS-102 1" BUTYL (PRIMARY & SECONDARY ROWS) & CS-212 6" EXTERIOR WRAP
6. ANY REQUIRED COATINGS, LINERS, OR ADMIXTURES TO BE SUPPLIED BY OTHERS
7. 36" X 36" HATCH SUPPLIED BY OTHERS - TO BE CAST INTO TOP OF MONOTOP
8. ALUMINUM LADDER & SAFETY POST SUPPLIED BY OTHERS
9. LINK-SEAL CONNECTORS SUPPLIED BY OTHERS

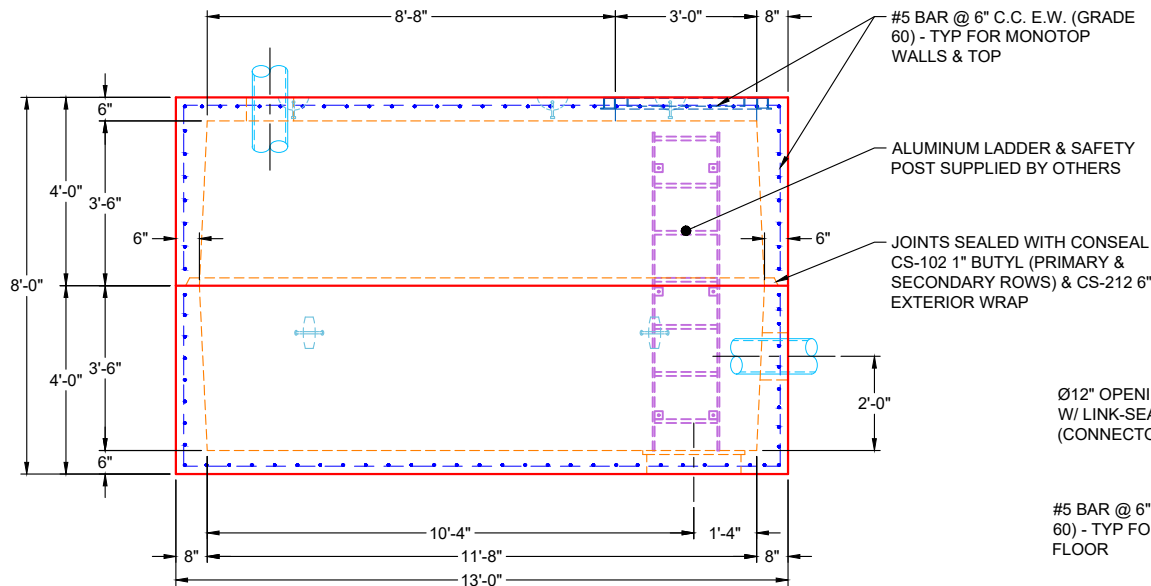

FRONT VIEW

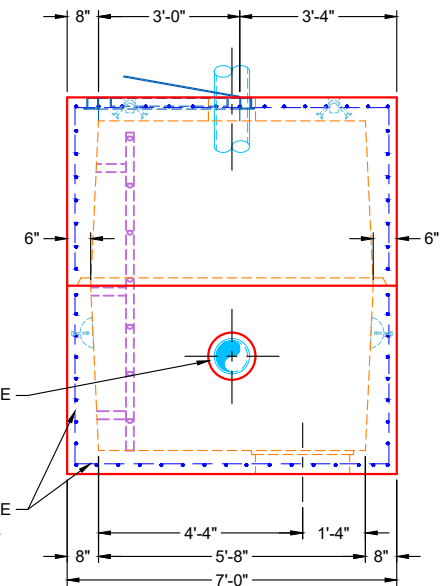

SIDE VIEW

REVISION INFORMATION

REV. DATE: NO REVISIONS TO DATE



SUBMITTAL DRAWING: 72" X 144" WELL VAULT

CUSTOMER: STRIEGEL DESIGN & CONSTRUCTION

PROJECT: 2025 NEW WELL FIELD

STRUCTURE: 2-54406-9

QUOTE/SALES ORDER NO: 25-4406

CHECKED BY: B. SMITH

DRAWN BY: K. CARDWELL

DATE: 02/11/26

SCALE: NTS

PG. 1 OF 1